



Conservation Advisory Board Meeting Agenda

Thursday April 11, 2024

This page intentionally left blank.



Notice of Meeting

Conservation Advisory Board

Thursday, April 11, 2024

4:00 p.m.

at the HCA Main Office 838 Mineral Springs Road, Ancaster

Hamilton Conservation Authority is now conducting meetings in a hybrid format via an in-person and WebEx platform.

All hybrid meetings can be viewed live on HCA's You Tube Channel:
<https://www.youtube.com/user/HamiltonConservation>

1. **Welcome** – Wayne Terryberry
2. **Declaration of Conflict of Interest** – Wayne Terryberry
3. **Approval of Agenda** – Wayne Terryberry
4. **Delegations**
5. **Member Briefing**
 - 5.1. HCA 2023 Annual Report – Lisa Burnside
 - 5.2. Fifty Point Wetland Verbal Update – Scott Peck
6. **Chair's Report on Board of Directors Actions** – Wayne Terryberry
 - CA 2405 Indigenous Interpretive Signage Proposal
 - CA 2406 Westfield Accession and Deaccession List
 - CA 2407 Artaban Road and Lower Lions Club Road Parking Areas - Amended

7. Approval of Minutes of Previous Meeting

7.1. Minutes – Conservation Advisory Board (February 8, 2024) – Wayne Terryberry Page1

8. Business Arising from the Minutes

9. Staff Reports/Memorandums

Reports for Recommendation

9.1. HCA Natural Hazard Infrastructure – Asset Management Plan
– Karen Phong/Jonathan Bastien Page 7

9.2. HCA Natural Hazard Infrastructure - Operation Plan
– Karen Phong/Jonathan Bastien Page 37

9.3 Saltfleet Study Area Master and Management Plans
– Madolyn Armstrong Page 445

10. New Business

11. Next Meeting – Thursday, June 13, 2024 at 4:00 p.m.

12. Adjournment

HAMILTON CONSERVATION AUTHORITY

Conservation Advisory Board

MINUTES

Thursday, February 8, 2024

Minutes of the Conservation Advisory Board meeting held on Thursday, February 8, 2024 at 4:00 p.m., held by video conference and livestreamed on YouTube.

PRESENT:

Wayne Terryberry – in the Chair	
Elise Copps	Tyler Cunningham
Natalie Faught	Brian McHattie
Haley McRae	Sherry O’Connor
Cortney Oliver	Noah Stegman

Susan Fielding – Ex-Officio

REGRETS: Jamie Freeman

STAFF PRESENT: **Rondalyn Brown, Lisa Burnside, Lindsay Davidson, Grace Correia, Gord Costie, Marlene Ferreira, Scott Fleming, Matt Hall, Cari Hobbs, Peter Lloyd, Griffin Moore, Scott Peck, Mike Stone, Jaime Tellier, and Sandra Wwinner**

OTHERS: **Media – None**

1. Welcome

The Chair called the meeting to order and welcomed everyone present.

2. Declaration of Conflict of Interest

The Chair asked members to declare any conflicts under the HCA Administrative By-law. There were none.

3. Approval of Agenda

The Chair requested any additions or deletions to the agenda.

**CA2401 MOVED BY: Noah Stegman
 SECONDED BY: Tyler Cunningham**

THAT the agenda be approved.

CARRIED

4. Delegations

There were none.

5. Election of Vice Chair

Election of 2024 Vice-Chair

Wayne Terryberry called for nominations for the 2024 Vice-Chair for the Conservation Advisory Board.

**Nominated: Sherry O'Connor
By – Mover: Brian McHattie**

The Chair called for nominations twice more. Having no further nominations, he asked Sherry O'Connor if they accept the nomination. The election for the office of Vice Chair of the Conservation Advisory Board for 2024 was then closed and the position acclaimed with the following resolution.

**CA 2402 MOVED BY: Natalie Fraught
 SECONDED BY: Tyler Cunningham**

THAT nominations for the 2024 Vice-Chair of HCA Board of Directors be closed and Sherry O'Connor be confirmed as Vice-Chair of the Hamilton Conservation Authority Board of Directors for 2024.

CARRIED

The Chair declared Sherry O'Connor as Vice-Chair of the Conservation Advisory Board for 2024 by acclamation.

6. Member Briefing

There was none.

7. Chairman's Report on Board of Directors Actions

The following items were approved by the Board of Directors at the February 1, 2024 meeting.

CA 2328 HCA Shoreline Management Plan
CA 2329 HCA Floodplain Mapping Projects – Status Update

8. Approval of Minutes of Previous Meeting

8.1. Minutes – Conservation Advisory Board (December 14, 2024)

CA 2403 **MOVED BY: Elise Copps**
 SECONDED BY: Natalie Faught

THAT the minutes of the December 14, 2024 Conservation Advisory Board meeting be approved.

CARRIED

9. Business Arising from the Minutes

9.1. Follow-up, Advance Day Use Purchase Pilot Program for 2023

Lindsay Davidson reviewed the program, providing a breakdown in the use of the Pass by conservation area. She noted it was particularly effective for groups who rented a pavilion or group areas as less time was needed at the gate to enter the conservation area.

Question arose re: day use visitors who don't have an advance ticket. Lindsay stated that the number of passes allotted to any area can be controlled, ensuring that annual pass members can still access the area on a drop-in basis.

The plan for the program is to be integrated into the conservation areas' regular operations for 2024.

CA 2404 **MOVED BY: Noah Stegman**
 SECONDED BY: Natalie Faught

THAT the Memorandum entitled Advance Day Use Purchase Pilot Program for 2023 be received.

CARRIED**10. Staff Reports/Memorandums****10.1. Indigenous Interpretive Signage Proposal**

Griffin Moore reviewed the plan: the creation and installation of interpretive panels focused on Indigenous history and culture along the Main Loop in the Dundas Valley.

It was noted that funding was being sought through the HCA Foundation and grant applications.

A working group will be struck, consisting of an internal staff committee as well as Indigenous partners; preliminary contacts have been made.

Members expressed their enthusiasm for the project as well as offering to provide their contacts to Indigenous people and/or groups.

**CA 2405 MOVED BY: Haley McRae
 SECONDED BY: Elise Copps**

THAT the Conservation Advisory Board recommended to the Board of Directors:

THAT the proposed Indigenous Interpretive Panels Project, as outlined in this report, be approved for implementation following the securement of funding.

CARRIED**10.2. Westfield Accession and Deaccession List**

Peter Lloyd reviewed the Accession list for 2023, providing additional details on the items recommended for accession, including a cherrywood baby's cradle; whisky bottle with a Maple Leaf embossed from the Prohibition era; and a brass table lamp with stained-glass from the early 20th century.

A request was made that future lists include photographs of the items up for consideration; staff agreed to do so.

**CA 2406 MOVED BY: Haley McRae
 SECONDED BY: Natalie Faught**

THAT the Conservation Advisory Board recommends to the Board of Directors:

THAT the Westfield 2023 Artifact Accessions List be accepted as the artifacts to be added to the Westfield Heritage Village Conservation Area and the Hamilton Conservation Authority collection.

CARRIED

Tyler Cunningham left the meeting.

10.3. Artaban Road and Lower Lions Club Road Parking Areas

Matt Hall provided a summary of the report. This was a follow up to the HCA Visitor Management & Vehicle Parking Review, which was completed and approved in 2019.

There was discussion regarding both protection of natural areas while also providing visitor access, particularly for the new proposed parking lot for Tiffany Falls, given the size of the conservation area and impacts visitors can have to the area.

Staff noted that waterfall areas are popular with limited parking and that our visitor management approach is to direct them to safe places to park and access these areas and keep them on trails and out of sensitive areas. Infrastructure is needed to consider any further visitor management approaches in the future and that marketing undertakes initiatives to direct visitors to areas such as Westfield with our expanded trail system to spread out visitation.

Natalie Faught left the meeting.

Following discussion, the original staff recommendation was revised through a friendly amendment to separate direction for the two parking areas as follows:

**CA 2407 MOVED BY: Brian McHattie
 SECONDED BY: Sherry O'Connor**

THAT the Conservation Advisory Board recommend to the Board of Directors:

THAT Staff be directed to complete detailed design for the Artaban Rd. Parking Lot Expansion project and formally submit a Development Permit Application for this project to the Niagara Escarpment Commission; and further

THAT Staff be directed to complete a capacity study of Tiffany Falls Conservation Area and return it to the Conservation Advisory Board prior to completing detailed design for the Parking Lot Addition project on Lower Lions' Club Road and formally submit a Development Permit Application for this project to the Niagara Escarpment Commission.

CARRIED

11. New Business

There was none.

12. Next Meeting

The next meeting of the CAB is scheduled for Thursday, April 11, 2024 at 4:00 p.m., at the HCA Main Administration Office – Woodend Auditorium.

13. Adjournment

On motion, the meeting was adjourned.

Report

TO: Conservation Advisory Board

FROM: Lisa Burnside, Chief Administrative Officer (CAO)

RECOMMENDED BY: T. Scott Peck, MCIP, RPP, Deputy CAO/Director, Watershed Management Services

PREPARED BY: Karen Phong, Project Engineer
Jeff Tweedle, Conservation Planner
Jonathan Bastien, P.Eng, Water Resources Engineer

MEETING DATE: April 11, 2024

RE: HCA Natural Hazard Infrastructure –
Asset Management Plan

STAFF RECOMMENDATION

THAT the Conservation Advisory Board recommends to the Board of Directors of the Hamilton Conservation Authority that the Hamilton Conservation Authority Natural Hazard Infrastructure - Asset Management Plan dated March 2024 be approved.

BACKGROUND & PURPOSE

On October 7th, 2021, the Province of Ontario enacted Ontario Regulation 686/21: Mandatory Programs and Services, under the *Conservation Authorities Act*. Section 5 of Ontario Regulation 686/21 established the requirement that an asset management plan be developed related to the HCA's water and erosion control infrastructure.

This Asset Management Plan (AMP) was developed with a goal to prioritize the needs of HCA owned flood and erosion control infrastructure. This AMP is the first iteration in the management process and covers a 20-year horizon timeline. It sets up an initial frame work and will be continually developed and refined in the planned updates.

The purpose of this report is to seek CAB and Board endorsement of the plan to comply with regulatory requirements.

STAFF COMMENT

The flood and erosion control infrastructures that HCA operates are the Christie Lake Dam, Valens Lake Dam and Mineral Springs detention reservoir, and Saltfleet wetland berms (BC-1).

The following tasks were completed for each asset:

1. Inventory assets and components,
2. Assess asset value and conditions,
3. Manage assets with a life cycle cost perspective,
4. Evaluate asset performance and levels of service,
5. Assessment of risk and prioritization,
6. Budget for rehabilitation, replacement or disposal of assets.

Levels of service, or goals at which assets are to accomplish, were developed for the assets. The required levels of service were determined to be:

- Provide public and operator safety,
- Provide flood and erosion control,
- Provide low flow control,
- Provide recreational use for conservation area users (not included for Mineral Springs Detention Reservoir as it does not serve a recreational purpose),
- Provide aquatic and terrestrial habitat (not included for Mineral Springs Detention Reservoir).

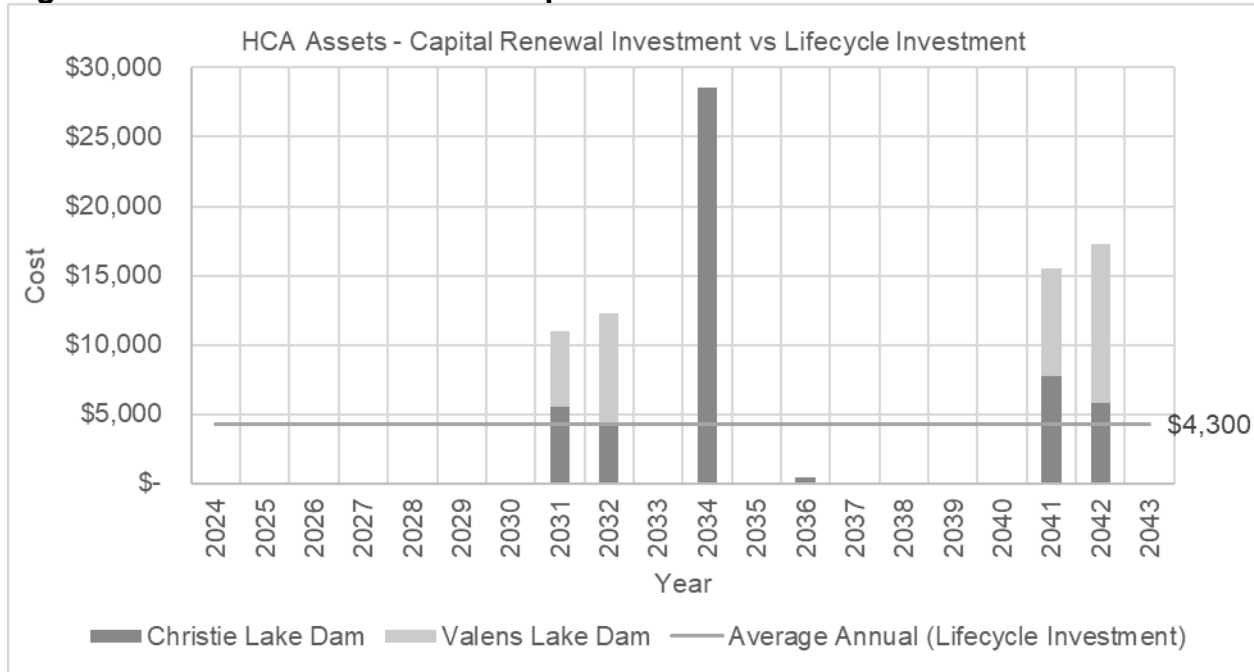
Assets were assessed in terms of their age, physical condition as well as their performance in relation to these levels of service. Generally, at the time of assessment, all asset components were in fair to very good condition, and overall; assets were performing at very good level of service.

A budget was prepared based on the replacement timelines and assessed asset values. Table 1 - summarizes the estimated required capital replacement costs in 5-year intervals for all four of HCA's assets. Figure 1 provides a visual representation of the annual replacement costs for the asset.

Table 1 – HCA Asset Replacement Requirements

Asset	1-5 Years	5-10 years	10-15 years	15-20 years
Christie Lake Dam	-	\$9,592.65	\$29,003.53	\$13,531.38
Valens Lake Dam	-	\$13,681.34	-	\$19,298.89
Mineral Spring Detention Reservoir	-	-	-	-
Saltfleet Wetlands (BC-1)	-	-	-	-
Total		\$23,500	\$29,100	\$33,000

Figure 1 – HCA Assets – Annual Replacement Costs vs Plan Horizon Investment



To meet the annual capital requirements based on projected costs, an average lifecycle investment was calculated, which estimates \$4,300 each year for the next 20-years.

STRATEGIC PLAN LINKAGE

The initiative refers directly to the HCA Strategic Plan 2019 – 2023:

- **Strategic Priority Area – Water Management**
 - Initiatives – Maintain and enhance our flood control infrastructure to address flooding and work to augment low flow conditions

AGENCY COMMENTS

N/A

LEGAL/FINANCIAL IMPLICATIONS

N/A

CONCLUSIONS

The HCA Infrastructure Asset Management Plan dated March, 2024 is part of the ongoing process of planning for HCA owned infrastructure. It sets up the initial framework and provides an estimated schedule and budget for the next 20-years with the anticipation of ongoing updates. This satisfies the requirement under Ontario Regulation 686/21 for the development of an asset management plan.

This page intentionally left blank.



Hamilton Conservation Authority

Asset Management Plan (Draft)

List of Revisions

Maintain updated list of revisions. Copy Water Resources Engineering.

Rev. No.	Date	Page No.	Revision Details
0.1	2024/03/13	n/a	Draft for Review

Distribution List

Name	Title

Table of Contents

1.0	Introduction.....	1
2.0	Objective	1
3.0	Background Information	1
4.0	Approach.....	1
5.0	Asset Inventory.....	1
5.1.1	Asset Inventory.....	1
5.1.2	Condition Assessments	2
5.1.3	Asset Value	2
5.1.4	Asset Lifecycle and Replacement Timelines	3
5.2	Christie Lake Dam.....	3
5.2.1	Asset Components of Christie Lake Dam.....	4
5.2.2	Asset Value of Christie Lake Dam	6
5.2.3	Asset Condition of Christie Lake Dam	7
5.2.4	Estimated Service Life and Asset Replacement of Christie Lake Dam.....	8
5.3	Valens Lake Dam.....	9
5.3.1	Asset Inventory of Valens Lake Dam.....	10
5.3.2	Asset Value of Valens Lake Dam	10
5.3.3	Asset Condition of Valens Lake Dam	11
5.3.4	Estimated Service Life and Asset Replacement of Valens Lake Dam.....	12
5.4	Mineral Springs Detention Reservoir.....	13
5.4.1	Asset Inventory of Mineral Springs Detention Reservoir.....	14
5.4.2	Asset Value of Mineral Springs Detention Reservoir	14
5.4.3	Asset Condition of Mineral Springs Detention Reservoir	14
5.4.4	Estimated Service Life and Asset Replacement of Mineral Springs Detention Reservoir	15
5.5	Saltfleet Wetlands (BC-1).....	15
5.5.1	Asset Inventory for Saltfleet Wetlands.....	16
5.5.2	Asset Value for Saltfleet Wetlands	16
5.5.3	Asset Conditions for Saltfleet Wetlands.....	17
5.5.4	Estimated Service Life and Asset Replacement of Saltfleet Wetlands	17
6.0	Levels of Service	18
7.0	Maintenance.....	18
8.0	Risk Assessment.....	18

9.0	Capital Replacement and Required Funding.....	20
10.0	Conclusions.....	21
11.0	Plan Improvements	21
12.0	References.....	22

Tables

Table 5-1 – Condition Assessment Ratings Table	2
Table 5-2 - Christie Lake Dam Asset Inventory	4
Table 5-3 - Christie Lake Dam Asset Value	6
Table 5-4 - Christie Lake Dam Asset Condition	7
Table-5-5 - Christie Lake Dam Estimated Service Life and Asset Replacement Timeline	8
Table 5-6 – Valens Lake Dam Asset Inventory	10
Table 5-7 - Valens Lake Dam Asset Value.....	11
Table 5-8 - Valens Lake Dam Asset Condition.....	11
Table 5-9 – Valens Lake Dam Estimated Service Life and Asset Replacement Timeline	12
Table 5-10 – Mineral Springs Detention Reservoir Asset Inventory	14
Table 5-11 – Mineral Springs Detention Reservoir Asset Value.....	14
Table 5-12 – Mineral Springs Detention Reservoir Asset Condition.....	14
Table 5-13 – Mineral Springs Detention Reservoir Estimated Service Life and Asset Replacement Timeline.....	15
Table 5-14 – Saltfleet Wetland Asset Inventory	16
Table 5-15 – Saltfleet Wetland Asset Value	16
Table 5-16 – Saltfleet Wetland Asset Condition	17
Table 5-17 – Saltfleet Wetlands Estimated Service Life and Asset Replacement Timeline.....	17
Table 6-1 – Asset Level of Service Performance	18
Table 8-1 -Probability of Failure Ratings	19
Table 8-2 -Asset Criticality Ratings	19
Table 8-3 - Risk Severity Matrix	19
Table 8-4 – Asset Risk Severity	20
Table 9-1 – HCA Asset Replacement Requirements	20

1.0 Introduction

On October 7th, 2021, the Province of Ontario enacted Ontario Regulation 686/21: Mandatory Programs and Services, under the Conservation Authorities Act: Section 5 of Ontario Regulation 686/21 established the requirement that an Asset Management Plan be developed and implemented for any water control structure that mitigates risks to life and damage to property due to flooding, provides flow augmentation, or provides erosion control. Hamilton Conservation Authority (HCA) operates several natural hazard structures that are subject to the regulation.

2.0 Objective

This Asset Management Plan (AMP) was developed to prioritize the needs of HCA owned flood and erosion control infrastructure. This AMP covers a 20-year time horizon and will be updated on an ongoing basis. HCA owns and operates a large number of assets as part of its operations, however the scope of this AMP is strictly for the management of flood control and erosion control assets. The plan will help guide and assist with decisions for maintenance, rehabilitation, repair or replacement.

3.0 Background Information

The flood and erosion control structures that HCA operates are the Christie Lake Dam, Valens Lake Dam, Mineral Springs detention reservoir, and Saltfleet wetland berms (BC-1). Their primary goal of these assets is to provide flood and/or erosion control for the Hamilton region. In addition to this, Christie Lake Dam, Valens Lake Dam and the Saltfleet Wetlands are within HCA owned conservation areas and provide recreational opportunities for the public.

4.0 Approach

The following steps were completed to prepare this AMP:

1. Inventory assets and component,
2. Assess assets value and conditions,
3. Manage assets with a life cycle cost perspective,
4. Evaluate asset performance and levels of service,
5. Assessment of risk and prioritization,
6. Budget for rehabilitation, replacement or disposal of assets.

5.0 Asset Inventory

5.1.1 Asset Inventory

An inventory was taken of HCA's flood and erosion infrastructure assets. Each asset was broken down into components that were categorized based on the infrastructure's design, maintenance and inspection requirements. Generally, a component was distinguished if maintenance or replacement can be done independently to improve asset condition.

5.1.2 Condition Assessments

The asset conditions were assessed using existing safety reviews, maintenance and inspection records and reports. Age of the asset, recent rehabilitation, repairs or upgrades were also considered in the asset condition.

Each asset component was given a rating on a scale between Very Poor to Very Good. The associated rating was quantified according Table 5-1 developed by the Canadian Network of Asset Managers.

Table 5-1 – Condition Assessment Ratings Table

Rating	Condition Description	Percentage Estimated Service Life remaining on asset (%)
Very Good	Well maintained good conditions, new or recently rehabilitated.	80-100
Good	Adequate for now. Acceptable, generally approaching mid stage of expected service life.	60-80
Fair	Requires attention. Signs of deterioration, some elements exhibit deficiencies.	40-60
Poor	At risk of affecting service. Approaching end of service life, condition below standard, large portion of system exhibits significant deterioration.	20-40
Very Poor	Unfit for sustained service. Near or beyond expected service life, widespread signs of advanced deterioration, some assets may be unusable.	<20%

The following documents were reviewed to make estimates on asset conditions:

- GHD, (September 28, 2023). Christie Lake Dam, Dam Safety Review.
- Tulloch, (March 12, 2021). Dam Safety Review - Valens Dam.
- Hamilton Conservation Authority, (2021) Mineral Springs Detention Reservoir Monthly Visual Inspection Summary.
- Hamilton Conservation Authority, (February 12, 2024) Post-Construction Monitoring of Saltfleet Wetlands (BC-1 East and West).
- Various other HCA regular maintenance and rehabilitation records.

5.1.3 Asset Value

The asset values in this AMP are high level estimates based on construction costs, where available, preliminary design costing at the time of project development, or rough estimates based on comparable projects, construction and materials. Therefore, the asset values in this AMP are to only be used for prioritization of asset management requirements and high-level budgeting for the preparation of a financial strategy. Where

data was not available, a placeholder value was used and should be updated in future updates to the AMP.

5.1.4 Asset Lifecycle and Replacement Timelines

Some definitions are provided to clarify terms used in this AMP include:

Designed Life Expectancy – the anticipated number of years that an asset is designed to last. This is typically based on industry standard and supplemented with experience with replacement history.

Level of Service – A measure of the performance of an asset against organizational goals. This is regardless of the asset physical condition.

Effective Age – The estimated age of the asset based on conditions assessments. The effective age was determined by the asset condition and its associated percent estimated service life remaining, see Table 5-1 – Condition Assessment Ratings Table.

Remaining Service Life – The anticipated number of years an asset has left until it is expected to be replaced.

Replacement Timeline – The anticipated date which the asset is to be replaced.

Each asset has a designed life expectancy after which it should be replaced. Routine inspections, maintenance and management can extend the life of the asset. Many of HCAs has asset components have reached or are approaching their designed life expectancy, but still maintain value, provide an adequate level of service and do not presently require replacement. Therefore, the replacement timeline of each asset was assessed and adjusted based on the estimated remaining service life.

$$\text{Estimated remaining service life} = \text{Design life expectancy} - \text{Effective age}$$

Several of the asset components have an estimated remaining service life exceeding the 20-year time horizon of this AMP. Regular condition assessments as part of the 5-year AMP review cycle will continually update the asset replacement requirements and capture the future maintenance and replacement costs.

5.2 Christie Lake Dam

The Christie Lake Dam is located on Spencer Creek, upstream of Dundas within the Christie Lake Conservation Area. The dam provides flood control and low flow augmentation. In addition, the dam reservoir provides recreational opportunities and fish habitat. Christie Lake Dam consists of the following components:

- A 109 m long concrete dam with Ogee emergency spillway with the crest elevation at 235.93 m. At the top of the spillway, 0.60 m high (total) flashboards are installed, which can be removed in case of a major flood.

- A control structure consisting of two Ogee spillways with the crest elevation at 231.65 m, controlled by two 4.88 m wide 4.88 m high radial gates or 1.52 m high steel panels during the winter. The maximum opening of the radial gates is 3.66 m.
- A drop inlet structure containing three 1.83 m wide stop log controlled bays, two 0.6 m x 0.6 m gate valves, and a 0.15m diameter low flow valve. The stop log bays have a sill elevation of 234.48 m. 0.53 m high (total) stop logs are installed in each bay during summer. The gate valves have an invert elevation of 229.52 m. The low flow valve has an invert elevation of 231.50 m.
- Earth embankments as the abutments.

5.2.1 Asset Components of Christie Lake Dam

The asset components of the Christie Lake Dam are summarized in Table 5-2.

Table 5-2 - Christie Lake Dam Asset Inventory

Asset ID	Component	Description
CD-001	Automatic Gauge	Automatic reservoir level gauge and rain gauge at the dam connected to data logger. Remotely accessed from HCA office.
CD-002	Staff Gauge	Imperial staff gauge on upstream side of south wingwall.
CD-003	Radial gates	Two radial gates on control structure, the radial gates are used to provide coarser flow control.
CD-004	Fall Arrest System	Fall arrest horizontal life line installed in the area of the gain covers in the walkway, as well as fall limiters and safety harnesses.
CD-005	Safety Boom	The permanent safety boom is installed upstream.
CD-006	Low Flow Valves	Two (2) 0.6x0.6 m low flow gate valves and one (1) 0.15 m diameter gate valve is located at the upstream face of three (3) low flow conduits through the drop inlet structure. The low flow valves are used to provide finer flow control.
CD-007	Radial Hoisting System	The motorized drum hoisting system, used for opening and closing the radial gates. This includes motors, drums, brakes, fan brakes, etc.
CD-008	Overflow Spillway Stop Logs	Timber beams located above overflow spillway, that are permanently installed to increase reservoir storage capacity prior to overflow.
CD-009	Access Road	Access road from Crooks Hollow Road, including vehicle gate.
CD-010	Handrails and Walkway over dam	Various galvanized handrail and non-slip coated walkway over the dam.
CD-011	Dam Concrete	Dam, radial gates stilling basin, low flow conduits stilling basin, drop inlet structure, four (4) wingwalls, overflow spillway, walkway deck and piers
CD-012	Dam Building	Building housing the dam operational controls, backup generator, and other electrical control panels. The dam building also includes a security camera facing the walkway of the dam, the dam building is equipped with

Asset ID	Component	Description
		an alarm system. The radial gate control panels, and reservoir level gauge have been included as other components.
CD-013	Overflow Spillway	Ogee weir, vegetated overflow spillway including earthen abutments.
CD-014	Drop Inlet Structure	Low flow outlet structure that houses the three (3) low flow conduits. This item includes two (2) maintenance valves located at the downstream face of the two (2) low flow conduits controlled by the 0.6x0.6 m valves. There are also trashracks installed around the inlets to each of the three (3) low flow conduits. Also included is the deck grating and access ladder. The three (3) low flow valves and low flow overflow stop logs have been included elsewhere.
CD-015	Tailrace	Downstream of the overflow spillway, including gabion basket walled section of outlet channel immediately downstream of the radial gates
CD-016	Reservoir	The total reservoir surface area within the watershed during summer is 72 ha. The watershed has a maximum reservoir storage capacity of about 395 ha-m (3,950,000 m ³) at elevation 237.44 m GSC (figures from Christie Lake Dam Safety Review, 2013)
CD-017	Radial Gate Control Panels	Two (2) control panels (one for each radial gate) located on the south wall in the electrical room in the dam building.
CD-018	Low Flow Overflow Stop Logs	Timber beams located above the three (3) low flow conduits in the Drop Inlet Structure, that are permanently used to establish typical summer reservoir water levels
CD-019	Winter Gates and Hoisting System	Two (2) steel winter gates that provide weir flow control in the winter, replacing the radial gate flow control. In the winter, the radial gates are stored in the fully open position, to avoid ice damage. Hoisting system including overhead gantry and two (2) chain manual pulley hoists, used for installing and removing the winter gates. Also includes the steel gain covers in the walkway over the dam, used for accessing the area.
CD-020	Earthen Abutments	The concrete dam has earthen abutments on either side
CD-021	Fencing	Safety fencing around both sides of the outlet channel downstream of the radial gates
CD-022	Signage	Twenty (20) "Danger", "Warning" or "No Trespassing" signs throughout the area.
CD-023	Lighting	X light posts are located along the reservoir side of the walkway over the dam

5.2.2 Asset Value of Christie Lake Dam

Asset values of Christie Lake Dam were determined using original construction costs and was inflated to 2024 costs using an annual average inflation rate of 3.5% (Table 5-3). Where initial purchase costs were not available, a best estimate based on experience was used to provide an idea of the overall magnitude of expected costs.

Table 5-3 - Christie Lake Dam Asset Value

Asset ID	Component	Year Purchased	Initial Purchase Cost	Inflation (Annual)	Estimated 2024 Overall Replacement Cost
CD-001	Automatic Gauges	2013	\$3,000.00	-	\$3,000.00
CD-002	Staff Gauge	1972	\$300.00	-	\$300.00
CD-003	Radial gates	1972	\$103,170.00	3.5%	\$617,236.53
CD-004	Fall Arrest System	-	\$10,000	-	\$10,000.00
CD-005	Safety Boom	2021	\$391,208.62	3.5%	\$433,739.99
CD-006	Low Flow Valves	2017	\$200,300.00	3.5%	\$254,837.54
CD-007	Radial Hoisting System	2019	\$666,413.51	3.5%	\$3,986,960.95
CD-008	Overflow Spillway Stop Logs	1972			
CD-009	Access Road	1972			
CD-010	Handrails and Walkway over dam	2011			
CD-011	Dam Concrete	1972			
CD-012	Dam Building	1972			
CD-013	Overflow Spillway	1972			
CD-014	Drop Inlet Structure	1972			
CD-015	Tailrace	1972			
CD-016	Reservoir	1972			
CD-017	Low Flow Overflow Stop Logs	1972			
CD-018	Winter Gates and Hoisting System	1972			
CD-019	Earthen Abutments	1972			
CD-020	Radial Gate Control Panels	2013	\$10,935.01	3.5%	\$15,964.78
CD-021	Fencing	2021	\$17,628.00	3.5%	\$19,544.48
CD-022	Signage	2021	\$3,174.17	3.5%	\$4,179.77
CD-023	Lighting	-	\$15,000.00	-	\$15,000.00
				Total	\$5,360,764.04

5.2.3 Asset Condition of Christie Lake Dam

The main source of asset conditions for Christie Lake Dam came from the most recent Dam Safety Review (GHD, 2024) along with other maintenance records and inspections. Condition ratings were chosen as per description in Table 5-1 – Condition Assessment Ratings Table. Table 5-4 summarizes the asset and the assigned condition rating.

Table 5-4 - Christie Lake Dam Asset Condition

Asset ID	Component	Condition Rating
CD-001	Automatic Gauge	Good
CD-002	Staff Gauge	Good
CD-003	Radial gates	Good
CD-004	Fall Arrest System	Good
CD-005	Safety Boom	Very Good
CD-006	Low Flow Valves	Very Good
CD-007	Radial Hoisting System	Good
CD-008	Overflow Spillway Stop Logs	Fair
CD-009	Access Road	Fair
CD-010	Handrails and Walkway over dam	Fair
CD-011	Dam Concrete	Fair
CD-012	Dam Building	Fair
CD-013	Overflow Spillway	Fair
CD-014	Drop Inlet Structure	Fair
CD-015	Tailrace	Fair
CD-016	Reservoir	Fair
CD-017	Low Flow Overflow Stop Logs	Fair
CD-018	Winter Gates and Hoisting System	Very Good
CD-019	Earthen Abutments	Good
CD-020	Radial Gate Control Panels	Good
CD-021	Fencing	Fair
CD-022	Signage	Very Good
CD-023	Lighting	Good

5.2.4 Estimated Service Life and Asset Replacement of Christie Lake Dam

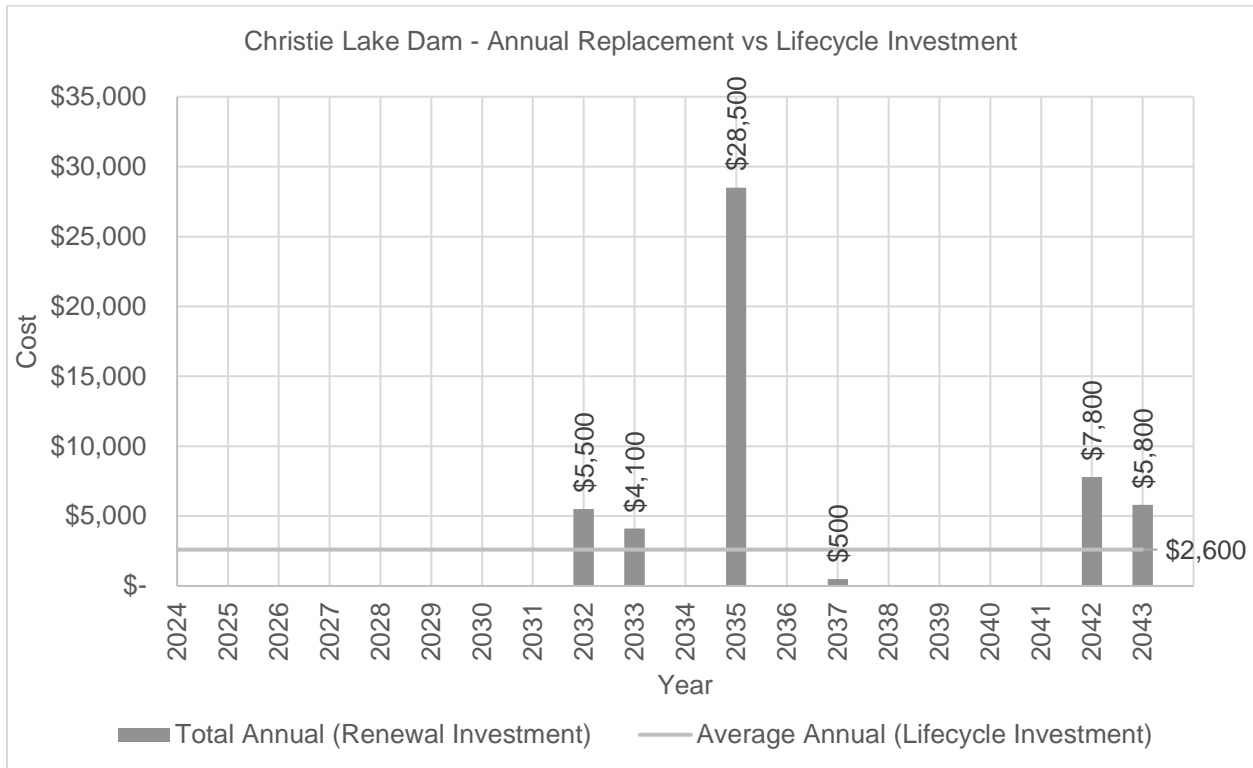
The asset replacement timelines are presented in Table-5-5, and shows the total budget required for replacement in 5-year intervals up to the 20-year planning horizon of the AMP. It uses the replacement costs determined in asset value table above, including inflation to the timelines estimated from the service life remaining. Several asset components were identified but grouped together by available costing information. In future AMP updates and as components are replaced or undergo maintenance, these can be updated individually and potentially extend the overall asset estimated service life.

Table-5-5 - Christie Lake Dam Estimated Service Life and Asset Replacement Timeline

Asset ID	Component	Year Installed	Estimated Service Life Remaining (Years)	1-5 Years	5-10 years	10-15 years	15-20 years
CD-001	Automatic Gauge	2013	10	-	\$4,100	-	\$5,800
CD-002	Staff Gauge	1972	14	-	-	\$500	-
CD-003	Radial gates	2019	35	-	-	-	-
CD-004	Fall Arrest System	2019	35	-	-	-	-
CD-005	Safety Boom	1972	67	-	-	-	-
CD-006	Low Flow Valves	1972	45	-	-	-	-
CD-007	Radial Hoisting System	2021	25				
CD-008	Overflow Spillway Stop Logs	2017					
CD-009	Access Road	1972					
CD-010	Handrails and Walkway over dam	1972					
CD-011	Dam Concrete	2011					
CD-012	Dam Building	1972					
CD-013	Overflow Spillway	1972					
CD-014	Drop Inlet Structure	1972					
CD-015	Tailrace	1972					
CD-016	Reservoir	1972					
CD-017	Low Flow Overflow Stop Logs	1972					
CD-018	Winter Gates and Hoisting System	1972					
CD-019	Earthen Abutments	1972					
CD-020	Radial Gate Control Panels	1966	35	-	-	-	-
CD-021	Fencing	2013	12	-	-	\$28,600	-
CD-022	Signage	2021	9	-	\$5,600	-	\$7,800
CD-023	Lighting	-	22	-	-	-	-

Figure 5-1 shows the annual replacement costs for the Christie Lake Dam asset components, as well as the average annual investment over the 20-year span of this AMP.

Figure 5-1 – Christie Lake Dam Replacement Timeline Costs



5.3 Valens Lake Dam

The Valens Lake Dam is located on Spencer Creek, near the community of Valens, Ontario within the Valens Conservation Area. The dam provides recreational opportunities and fish habitat, but does also provide some flood control. The dam consists of the following components:

- A 121.9 m long earth-fill embankment with a crest elevation at 277.3 m and a toe elevation of 270.8 m.
- The dam has a concrete overflow culvert with a drop inlet. The concrete drop inlet spillway has the crest elevation at 274.64 m. Stoplogs can be placed in the concrete drop inlet structure to raise the water level up to 275.25 m.
- A square low-level intake (0.91 m by 0.91 m) is controlled by a 0.36 m diameter valve. The invert elevation of the intake is 270.80 m.

5.3.1 Asset Inventory of Valens Lake Dam

The asset components of the Valens Lake Dam are summarized in Table 5-6.

Table 5-6 – Valens Lake Dam Asset Inventory

Asset ID	Component	Description
VD-001	Signage	Fourteen (14) "Danger", "No Trespassing" and Contact Information signs throughout the site.
VD-002	Drop Inlet Structure	Concrete drop inlet structure deck grating and low flow inlet pipe and trashrack. The one (1) low flow valve, one (1) outflow conduit, and overflow stop logs have been included elsewhere.
VD-003	Access Road	Road topping on crest for vehicle access, including two (2) vehicle gates.
VD-004	Gauges	Automatic reservoir level gauge and rain gauge at the dam connected to data logger. Remotely accessed from HCA office.
VD-005	Staff Gauge	Staff gauge on side of drop inlet structure wall.
VD-006	Handrails	Handrails providing fall protection at outlet to outflow conduit.
VD-008	Low Flow Valve	Low level intake controlled by 0.36 m diameter valve.
VD-009	Dam Concrete	Outflow conduit, drop inlet structure, two (2) wingwalls, scour pad at outlet of outflow conduit.
VD-010	Outlet Channel	Short section of constructed outlet channel, including gabion basket banks, near outlet of outflow conduit
VD-011	Dam Earth Embankment	Impervious fill overlain with pervious fill on upstream and downstream slopes.
VD-012	Stoplogs	Custom stoplogs are seasonally installed around the three (3) open sides of the drop inlet structure, to establish typical summer reservoir water levels.
VD-013	Upstream Erosion Protection	Riprap on upstream slope of dam earth embankment.
VD-014	Reservoir	Upstream detention storage from dam, Valens Lake.
VD-015	Piezometers	Four piezometers installed along cross-section with data loggers, used to monitor for seepage through the dam.

5.3.2 Asset Value of Valens Lake Dam

Asset values of Valens Lake dam were determined using preliminary design construction costs, or more recent component replacement and inflated using an annual average inflation rate of 3.5% (Table 5-7). Where initial purchase costs were not available, a best estimate based on experience was used to provide an idea of the general magnitude of expected costs.

Table 5-7 - Valens Lake Dam Asset Value

Asset ID	Asset Component	Year Purchased	Initial Purchase Cost	Inflation (Annual)	2024 Overall Replacement Cost
VD-001	Signage	2021	\$3,174.17	3.5%	\$4,179.77
VD-002	Drop Inlet Structure	1966	-	3.5%	\$19,121.13
VD-003	Access Road	1966	\$6,500.00	3.5%	\$47,802.83
VD-004	Gauges	2015	-	-	\$3,000.00
VD-005	Staff Gauge	2009	-	-	\$3,000.00
VD-006	Handrails	1966	\$800.00	3.5%	\$5,883.43
VD-007	Low Flow Valve	-	-	-	\$254,837.54
VD-008	Dam Concrete	1966	\$22,000.00	3.5%	\$161,794.21
VD-009	Outlet Channel	1966	\$2,600.00	3.5%	\$19,121.13
VD-010	Dam Earth Embankment	1966	\$21,000.00	3.5%	\$154,439.93
VD-011	Stoplogs	2013	\$6,870.40	3.5%	\$10,030.58
VD-012	Upstream Erosion Protection	1966	\$4,200.00	3.5%	\$30,887.99
VD-013	Reservoir	1966	\$7,500.00	3.5%	\$55,157.12
VD-014	Piezometers	2019	-	-	\$26,129.10
				Total	\$795,384.74

5.3.3 Asset Condition of Valens Lake Dam

The main source of asset conditions for Valens Lake Dam came from the most recent Dam Safety Review (Tulloch, 2021) along with other maintenance records and inspections. Condition ratings were chosen as per description in Table 5-1 – Condition Assessment Ratings Table. Table 5-8 summarizes asset components and assigned condition rating.

Table 5-8 - Valens Lake Dam Asset Condition

Asset ID	Components	Condition Rating
VD-001	Signage	Very Good
VD-002	Drop Inlet Structure	Fair
VD-003	Access Road	Fair
VD-004	Gauges	Good
VD-005	Staff Gauge	Good
VD-006	Handrails	Fair
VD-007	Low Flow Valve	Good
VD-008	Dam Concrete	Fair
VD-009	Outlet Channel	Fair
VD-010	Dam Earth Embankment	Good
VD-011	Stoplogs	Good
VD-012	Upstream Erosion Protection	Fair
VD-013	Reservoir	Fair
VD-014	Piezometers	Good

5.3.4 Estimated Service Life and Asset Replacement of Valens Lake Dam

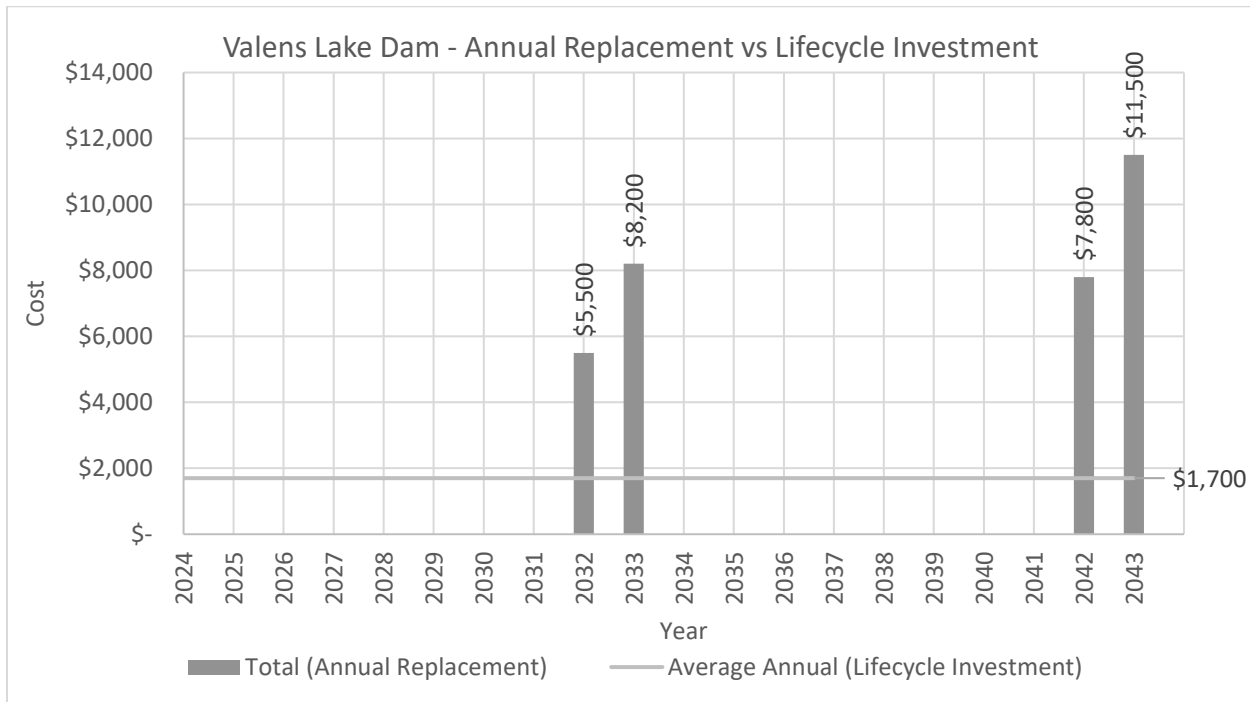
The asset replacement timelines are presented in Table 5-9, and shows the total budget required for replacement in 5-year intervals up to the 20-year span of this AMP. It uses the replacement costs determined in asset value table above, including inflation to the timelines estimated from the service life remaining.

Table 5-9 – Valens Lake Dam Estimated Service Life and Asset Replacement Timeline

Asset ID	Asset Component	Year Installed	Estimated Service Life Remaining	1-5 Years	5-10 years	10-15 years	15-20 years
VD-001	Signage	2021	9	-	\$5,600	-	\$7,800
VD-002	Drop Inlet Structure	1966	25	-	-	-	-
VD-003	Access Road	1966	25	-	-	-	-
VD-004	Gauges	2015	10	-	\$4,100	-	\$5,800
VD-005	Staff Gauge	2009	10	-	\$4,100	-	\$5,800
VD-006	Handrails	2013	25	-	-	-	-
VD-007	Low Flow Valve	1966	35				
VD-008	Dam Concrete	1966	25	-	-	-	-
VD-009	Outlet Channel	1966	25	-	-	-	-
VD-010	Dam Earth Embankment	2005	35	-	-	-	-
VD-011	Stoplogs	2013	35	-	-	-	-
VD-012	Upstream Erosion Protection	1966	25	-	-	-	-
VD-013	Reservoir	1966	25	-	-	-	-
VD-014	Piezometers	1966	35	-	-	-	-

Figure 5-2 shows the annual replacement cost for the Valens Lake Dam asset, as well as the average annual investment over the 20-year span of this AMP.

Figure 5-2 - Valens Lake Dam Replacement Timeline Costs



5.4 Mineral Springs Detention Reservoir

The Mineral Springs detention reservoir is located on Sulphur Creek and created as a result of the crossing at an unpaved section of Martin Road. The Martin Road section representing the embankment is 240 m long with a weir crest protected by concrete over a length of 30 m. The crest elevation of Martin Road at the low point for the crossing is 188.46 m. A riser pipe inlet is included on a 0.60 m diameter culvert. The invert elevation of the culvert is 183.50 m. Unlike the other three infrastructures, the Mineral Springs detention reservoir is designed to overtop Martin Road for storm events near and larger than the 10-year design storm.

Mineral Springs detention reservoir was constructed in 1985 to provide flood protection for several properties along Sulphur Creek downstream. HCA entered into an easement/maintenance agreement with the town of Ancaster (City of Hamilton) for the Mineral Springs detention reservoir. The town agreed to maintain and repair the detention reservoir in accordance with accepted engineering practice and as outlined in the operation, maintenance and safety manual, while HCA is responsible for Capital Works to the embankment and culvert structure. It is understood that the City of Hamilton owns Martin Road as well as the embankment and culvert structure; while HCA owns the land upstream of the road which is used as flood detention storage. HCA replaced the outlet structure including culvert and rehabilitated the outlet stilling basin in 2015.

5.4.1 Asset Inventory of Mineral Springs Detention Reservoir

Table 5-10 summarizes the asset inventory of the Mineral Springs Detention Reservoir.

Table 5-10 – Mineral Springs Detention Reservoir Asset Inventory

Asset ID	Component	Description
MSD-001	Earth Embankment	Earthen berm with impermeable core, and semi-impermeable cover, including geogrid and riprap surface protection.
MSD-002	Outlet Structure	Corrugated steel pipe riser, culvert, and amourstone headwall
MSD-003	Access Road	Driving surface on top of berm
MSD-004	Outlet scour pad	Stone dissipation pad

5.4.2 Asset Value of Mineral Springs Detention Reservoir

Mineral Springs detention reservoir asset values were estimated based preliminary design costing and the successful contractor tender prices for the 2015 rehabilitation of the outlet structure and outlet stilling basin. Table 5-11 summarizes the asset value of the Mineral Springs Detention Reservoir and uses an annual inflation rate of 3.5% to estimate overall replacement costs in 2024.

Table 5-11 – Mineral Springs Detention Reservoir Asset Value

Asset ID	Asset Component	Year Purchased	Initial Purchase Cost	Inflation (Annual)	2024 Overall Replacement Cost
MSD-001	Earth Embankment	1985	\$92,000.00	3.5%	\$351,934.20
MSD-002	Outlet Structure	2015	\$21,790.00	3.5%	\$29,697.53
MSD-003	Access Road	1985	\$3,500.00	3.5%	\$13,388.80
MSD-004	Outlet scour pad	2015	\$1,620.00	3.5%	\$2,207.89
				Total	\$397,228.43

5.4.3 Asset Condition of Mineral Springs Detention Reservoir

Asset conditions of the Mineral Springs Detention Reservoir was based on routine operational monitoring, age of the asset, and recent rehabilitation. Table 5-12 summarizes the asset components and condition ratings.

Table 5-12 – Mineral Springs Detention Reservoir Asset Condition

Asset ID	Components	Condition Rating
MSD-001	Earth Embankment	Fair
MSD-002	Outlet Structure	Good
MSD-003	Access Road	Fair
MSD-004	Outlet stilling basin	Good

5.4.4 Estimated Service Life and Asset Replacement of Mineral Springs Detention Reservoir

The asset replacement timelines are presented in Table 5-13, and shows the total budget required for replacement in 5-year intervals up to the 20-year span of this AMP. Based on current condition assessment and the estimated service life remaining of the infrastructure, no major replacements are expected within this AMP time horizon.

Table 5-13 – Mineral Springs Detention Reservoir Estimated Service Life and Asset Replacement Timeline

Asset ID	Asset Component	Year Installed	Estimated Service Life Remaining (Years)	1-5 Years	5-10 years	10-15 years	15-20 years
MSD-001	Earth Embankment	1985	25	-	-	-	-
MSD-002	Outlet Structure	2015	35	-	-	-	-
MSD-003	Access Road	1985	25	-	-	-	-
MSD-004	Outlet stilling basin	2015	35	-	-	-	-

5.5 Saltfleet Wetlands (BC-1)

The BC-1 wetlands are the first completed of several that are planned for the Saltfleet Wetlands project. The BC-1 wetlands were designed to retain water in the upper Battlefield Creek to address flooding and erosion concerns downstream. The Saltfleet wetland berms (BC-1) are two separate wetland containment berms (East and West) that are located in HCA's Saltfleet Conservation Area at 444 First Road East. The BC-1 East and West wetlands are part of the larger Saltfleet wetlands system, that will include several locations along Battlefield Creek and Stoney Creek. The BC-1 East and West wetlands provide flood and erosion control as well as low flow augmentation to downstream reaches of Battlefield Creek. The Saltfleet wetland berms (BC-1 East and West) each consist of a clay core earth berm, with an outlet structure and emergency spillway. Each outlet structure consists of a riser pipe and a corrugated steel culvert through the berm. The berm crest elevations of the East and West berms are 189.27 m and 188.86 m respectively. The East berm steel culvert is 1.00 m diameter, with an invert elevation of 187.62 m. The West berm steel culvert is 0.70 m diameter, with an invert elevation of 187.34 m.

5.5.1 Asset Inventory for Saltfleet Wetlands

. Table 5-14 summarizes the current wetland asset inventory for the Saltfleet Wetlands.

Table 5-14 – Saltfleet Wetland Asset Inventory

Asset ID	Component	Description
SF-001	Earthen Embankment (Berm) West & East	Earthen berms with impermeable core, and semi-impermeable cover, as well as riprap protection on a portion of the wetland-side slope.
SF-002	Outlet Structure West	Corrugated Steel Pipe Riser, Culvert, Concrete headwall, and riprap spillway
SF-003	Outlet Structure East	Corrugated Steel Pipe Riser, Culvert, Concrete headwall, and riprap spillway
SF-004	Pedestrian Walkway West & East	Limestone gravel pathway spanning the entire berm West & East
SF-005	Downstream Dissipation Pads West & East	Stone dissipation pads downstream of both of Outlet Structure West & East
SF-006	Wetlands & Wetland features West & East	Vegetated wetland with various habitat features (sunning logs, refuge wood piles, and refuge stone piles)
SF-007	Drainage Ditches East	Constructed drainage ditches x 2 to drain external drainage around the berm East at the northern and eastern sections, including culverts x 2 at the trail connection to the Dofasco Trail

5.5.2 Asset Value for Saltfleet Wetlands

Costs for the Saltfleet Wetland Asset Value were estimated based on the successful contractor tender prices for the 2022 construction project. Table 5-14 summarizes the asset value of the Saltfleet Wetlands and uses an annual inflation rate of 3.5% to estimate overall replacement costs in 2024.

Table 5-15 – Saltfleet Wetland Asset Value

Asset ID	Asset Component	Year Purchased	Initial Purchase Cost	Inflation (Annual)	2024 Overall Replacement Cost
SF-001	Earthen Embankment (Berm) West & East	2022	\$221,984.00	3.5%	\$237,335.53
SF-002	Outlet Structure West	2022	\$60,575.50	3.5%	\$64,764.66
SF-003	Outlet Structure East	2022	\$60,575.50	3.5%	\$64,764.66
SF-004	Pedestrian Walkway West & East	2022	\$16,695.00	3.5%	\$17,849.56
SF-005	Downstream Dissipation Pads West & East	2022	\$21,294.00	3.5%	\$22,766.61
SF-006	Wetlands & Wetland features West & East	2022	\$250,722.00	3.5%	\$368,579.67
SF-007	Drainage Ditches East	2022	\$21,600.00	3.5%	\$23,138.46
				Total	\$699,987.69

5.5.3 Asset Conditions for Saltfleet Wetlands

Asset conditions for the Saltfleet Wetlands are considered very good as they were recently constructed and in new condition. In addition to this, the regular monthly and annual post-construction monitoring completed internally by HCA staff was considered and support this condition assessment.

Table 5-16 – Saltfleet Wetland Asset Condition

Asset ID	Components	Condition Rating
SF-001	Earthen Embankment (Berm)	Very Good
SF-002	Outlet Structure West	Very Good
SF-003	Outlet Structure East	Very Good
SF-004	Pedestrian walkway and overflow spillway	Very Good
SF-005	Downstream Dissipation Pond	Very Good
SF-006	Wetland Reservoir	Very Good
SF-007	Drainage Ditches East	Very Good

5.5.4 Estimated Service Life and Asset Replacement of Saltfleet Wetlands

Table 5-17 summarizes the Saltfleet Wetlands estimated service life and the cost of asset replacement over the 20-year span of this asset management plan. Given that this is a newly constructed infrastructure, the replacement timelines are beyond this management plan’s assessment, therefore no replacement costs are expected.

Table 5-17 – Saltfleet Wetlands Estimated Service Life and Asset Replacement Timeline

Asset ID	Asset Component	Year Installed	Estimated Service Life Remaining (Years)	1-5 Years	5-10 years	10-15 years	15-20 years
SF-001	Earthen Embankment (Berm)	2022	45	-	-	-	-
SF-002	Outlet Structure West	2022	45	-	-	-	-
SF-003	Outlet Structure East	2022	45	-	-	-	-
SF-004	Pedestrian walkway and overflow spillway	2022	45	-	-	-	-
SF-005	Downstream Dissipation Pond	2022	45	-	-	-	-
SF-006	Wetland Reservoir	2022	45	-	-	-	-
SF-007	Drainage Ditches East	2022	45				

6.0 Levels of Service

The desired level of service is used to determine optimal performance of the asset. The following are prioritized goals and levels of service that were considered for the flood infrastructure assets.

1. Provide public and operator safety,
2. Provide flood and erosion control,
3. Provide low flow control,
4. Provide recreational use for conservation area users (not included for Mineral Springs Detention Reservoir as it does not serve a recreational purpose),
5. Provide aquatic and terrestrial habitat (not included for Mineral Springs Detention Reservoir).

Each flood and erosion control infrastructure were rated based on their performance of each of the goals. Table 6-1 summarizes the assets their overall level of service.

Table 6-1 – Asset Level of Service Performance

Asset	Overall Level of Service Performance
Christie Lake Dam	Very Good
Valens Lake Dam	Very Good
Mineral Springs Detention Reservoir	Very Good
Saltfleet Wetlands (BC-1)	Very Good

7.0 Maintenance

Continual maintenance and inspections can extend the service life of an asset. HCA completes necessary regular maintenance and repair works in response to findings from regular safety reviews (done by external professional engineers) as well as through routine inspections by HCA staff done through operations of the assets. These are part of the regular operations of the assets and not included in this AMP. HCA has prepared a Natural Hazards Infrastructure Operational Plan which outlines the operational tasks.

The schedule for completion of necessary proactive regular maintenance/repair works is dependent on the nature and magnitude of the maintenance or repair. The appropriate schedules are confirmed with Professional Engineers. The repair designs are completed, as necessary, by external Professional Engineers.

8.0 Risk Assessment

A high-level assessment of risks was completed for the asset and their components. The probability of failure was categorized by the infrastructure condition, and the criticality of failure was categorized by the replacement cost and estimated impact on operations levels of service. Table 8-1 provides the probability of failure ratings based on asset condition. Table 8-2 summarizes the economic and operational factors

considered in asset criticality and ratings used for the risk assessment. Table 8-3 summarizes the risk assessment and the severity matrix.

Table 8-1 -Probability of Failure Ratings

Condition	Probability of Failure Rating
Very Good	(1) Very Unlikely
Good	(2) Not Likely
Fair	(3) Possible
Poor	(4) Likely
Very Poor	(5) Very Likely

Table 8-2 -Asset Criticality Ratings

Asset Criticality	Ratings
Cost	(1) Insignificant (2) Minor (3) Moderate (4) Major (5) Severe
Public and operator safety	
Flood control	
Low flow control	
Recreational use	

Table 8-3 - Risk Severity Matrix

Risk Severity Matrix		Criticality of Failure				
		Insignificant	Minor	Moderate	Major	Severe
Probability of Failure	Very Unlikely	Low	Low	Low	Low	Low/Moderate
	Not Likely	Low	Low/Moderate	Low/Moderate	Moderate	Moderate
	Possible	Low	Low/Moderate	Moderate	Moderate	Moderate/High
	Likely	Low	Moderate	Moderate	Moderate/High	High
	Very Likely	Low/Moderate	Moderate	Moderate/High	High	High

Based on the risk assessment, it was found that the majority of assets components are within the lower to moderate range of risk severity, with 21% being in the low to moderate range, and 79% in the moderate range. Table 8-4 summarizes the number of assets and the percentage of asset value in the respective ranges.

Table 8-4 – Asset Risk Severity

Asset Risk Severity	Number of Asset	Percentage of Assets	Percentage of Total Asset Value
Lower	13	30%	14.5%
Lower to Moderate	9	24%	6.2%
Moderate	19	46%	79.3%
Moderate to Higher	5	0%	0%
Higher	0	0%	0%
Total Number of Assets	46	100%	100%

The criticality weighting and ratings were assigned on a high-level assessment at this stage of asset management planning. It is HCA’s intention to further develop methodology, policy and strategies employed in asset management planning as part of continual process improvement for the AMP.

The risk severity is only intended to be used as a tool to prioritize asset rehabilitation, maintenance or replacement planning.

9.0 Capital Replacement and Required Funding

This AMP examined the performance of the assets and components in both their physical condition and level of service. With the performance and the associated replacement timelines, an estimate of annual requirements and the 20-year lifecycle investment was determined.

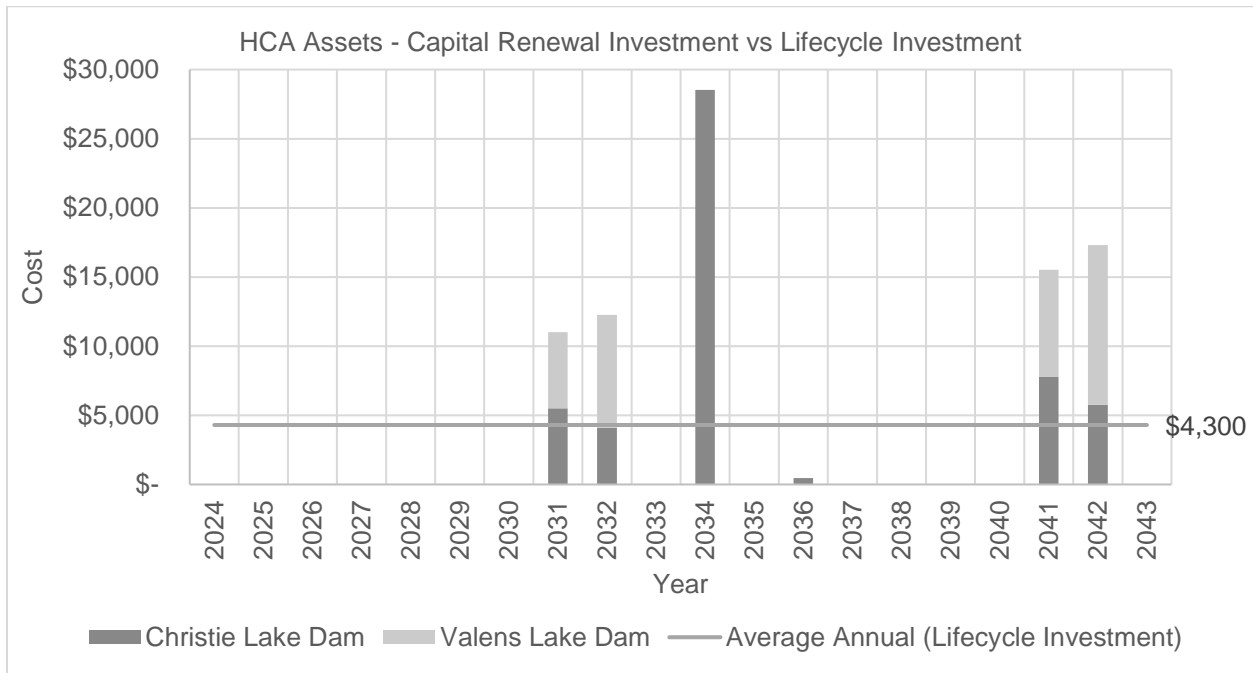
Table 9-1 summarizes the estimated required capital replacement costs in 5-year intervals for all four of HCA’s assets. The total estimated capital replacement cost for the 20-year horizon is \$85,600.

Table 9-1 – HCA Asset Replacement Requirements

Asset	1-5 Years	5-10 years	10-15 years	15-20 years
Christie Lake Dam	-	\$9,592.65	\$29,003.53	\$13,531.38
Valens Lake Dam	-	\$13,681.34	-	\$19,298.89
Mineral Spring Detention Reservoir	-	-	-	-
Saltfleet Wetlands (BC-1)	-	-	-	-
Total		\$23,500	\$29,100	\$33,000

Figure 9-1 provides a visual representation of the annual replacement costs for the asset. As mentioned in the Maintenance section, continual updates to the AMP as well as maintenance and inspection can help extend the service life until maintenance costs exceed the value and level of service that the asset provides. This AMP does not include operational or maintenance costs at this stage.

Figure -1 - HCA Assets – Annual Replacement vs Lifecycle Investment



To meet the annual capital requirements based on projected costs, an average lifecycle investment was calculated, which estimates \$4,300 each year for the next 20-years.

10.0 Conclusions

This asset management plan provides an inventory of assets, a valuation of each asset component, and a lifecycle analysis. It summarizes that in the next 20 years, HCA will have an estimated capital replacement cost of \$85,600. To meet this requirement, the HCA may budget an estimated annual lifecycle investment of \$4,300/year.

The AMP also assessed the level of service that each asset was providing and also conducted a high-level risk assessment. It found that that 79% of the total asset value is within the moderate risk classification and should be prioritized. With continual maintenance and inspections, future iterations of AMP can see that the lifecycle of the assets can be extended.

11.0 Plan Improvements

It is HCA’s goal to continually improve the AMP by prioritizing collection of relevant information through operational activities including future inspections, conditions, and cost assessments.

This AMP was completed based on available information collected over existing inspections, reviews and assessments and available cost information. Specific condition assessments or reports were not completed for this iteration of the AMP. A level of uncertainty is assumed when making estimates on asset service life, maintenance

requirement and replacement costs. Through further development and iterations of the AMP, these estimates are to be adjusted and refined.

Some tasks that HCA can focus on to improve the AMP process include:

1. Outline opportunities for planning with city and partners;
2. Conditions assessment with a priority on asset management as well as safety;
3. Updating replacement cost estimates with up to date sources and fill in data gaps where assumptions have been made;
4. Refinement of level of service, risk severity, and further development of methodology to objectively rate performance;
5. Focus on asset maintenance costs and consider treatment or maintenance timelines in addition to replacement timelines;
6. Integration with the rest of the organization's assets;
7. Integrate and standardize conditions assessments of all assets and
8. Develop organization wide AMP methodology, policy and strategy.

12.0 References

Canadian Network of Asset Managers. (2021). Asset Management 101, Version 1.2.
Kawartha Region Conservation Authority. (2022). Asset Management Plan.
Lakehead Region Conservation Authority. (2021). Asset Management Plan Update.



Report

TO: Conservation Advisory Board

FROM: Lisa Burnside, Chief Administrative Officer (CAO)

RECOMMENDED BY: T. Scott Peck, MCIP, RPP, Deputy CAO/Director,
Watershed Management Services

PREPARED BY: Karen Phong, Project Engineer
Jonathan Bastien, P.Eng, Water Resources Engineer

MEETING DATE: April 11, 2024

RE: HCA Natural Hazard Infrastructure - Operational Plan

STAFF RECOMMENDATION

THAT the Conservation Advisory Board recommends to the Board of Directors of the Hamilton Conservation Authority that the Hamilton Conservation Authority Operational Plan dated March, 2024 be approved.

BACKGROUND & PURPOSE

On October 7th, 2021, the Province of Ontario enacted Ontario Regulation 686/21: Mandatory Programs and Services, under the *Conservation Authorities Act*. Section 4 of Ontario Regulation 686/21 established the requirement that Operational Plan related to the HCA's water and erosion control infrastructure be developed, where such a plan is deemed necessary by the Conservation Authority.

HCA performs a number of operational tasks for each flood and erosion control infrastructure as required by regulations. The operational plan was prepared to summarize operational tasks for the HCA flood and erosion control infrastructure into one program.

The purpose of this report is to seek CAB and Board endorsement of the operational plan to comply with regulatory requirements.

STAFF COMMENT

The flood and erosion control infrastructures that HCA operates are the Christie Lake Dam, Valens Lake Dam and Mineral Springs detention reservoir, and Saltfleet wetland berms (BC-1). The operational plan summarizes required tasks under normal and flooding conditions. It describes management activities including regular inspections and the required regulatory tasks including safety reviews and update to operations manuals, emergency preparedness and public safety plans. In addition, the operations plan provides a summary of recently completed tasks and upcoming required tasks to be scheduled.

STRATEGIC PLAN LINKAGE

The initiative refers directly to the HCA Strategic Plan 2019 – 2023:

- **Strategic Priority Area – Water Management**
 - Initiatives – Maintain and enhance our flood control infrastructure to address flooding and work to augment low flow conditions

AGENCY COMMENTS

N/A

LEGAL/FINANCIAL IMPLICATIONS

N/A

CONCLUSIONS

The HCA Infrastructure Operational Plan dated March, 2024 summarizes these operational tasks for the HCA owned flood and erosion control infrastructure. The Natural Hazard Operational Plan consolidates this information under one plan and satisfies the requirement under Ontario Regulation 686/21 relating to operational plans to be developed when deemed required by the Conservation Authority.



Hamilton Conservation Authority

Infrastructure Operational Plan (Draft)

March 2024

Contents

1	Introduction.....	1
2	Objective.....	1
3	Background	1
3.1	HCA Infrastructure	1
3.2	Regulatory Framework and Dam Safety	3
4	Flood and Erosion Control Infrastructure Management Program.....	4
4.1	Inspection Program.....	4
4.2	Operation, Maintenance and Surveillance and Safety Manual Updates	5
4.3	Emergency Preparedness and Response Plans Updates	6
4.4	Public Safety Plans Updates.....	6
4.5	Repairs and Preventative Maintenance	6
5	Infrastructure Specific Operations.....	7
5.1	Christie Lake Dam Operations	7
5.2	Valens Lake Dam Operations	8
5.3	Mineral Springs Detention Reservoir.....	9
6	Summary of Operational Program Tasks from 2000 – 2023.....	10
6.1	Christie Lake Dam.....	11
6.2	Valens Lake Dam.....	13
6.3	Mineral Springs Detention Reservoir.....	15
6.4	Saltfleet Wetland Berms.....	16
7	Upcoming Operational Tasks	17
8	Appendices.....	18

Tables

Table 3-1– Dam Safety Review Periods.....	3
Table 6-1 - Christie Lake Dam Operational Tasks Summary	11
Table 6-2 - Valens Lake Dam Operational Tasks Summary	13
Table 6-3 - Mineral Springs Detention Reservoir Operational Tasks Summary	15
Table 6-4 – Saltfleet Wetland Berms Operational Tasks Summary	16
Table 7-1 - Infrastructure and Operational Review Schedule.....	17

1 Introduction

On October 7th, 2021, the Province of Ontario enacted Ontario Regulation 686/21: Mandatory Programs and Services, under the Conservation Authorities Act: Section 5 of Ontario Regulation 686/21 established the requirement that an Operational Plan be developed and implemented for any water control structure that mitigates risks to life and damage to property due to flooding or to assists flow augmentation, as well as any erosion control infrastructure. Hamilton Conservation Authority (HCA) operates four water control structures.

2 Objective

HCA performs a number of operational tasks for each flood and erosion control infrastructure as required by regulations. The objective of this operational plan is to outline and summarize these operational tasks for the HCA flood and erosion control infrastructure into one program. The operational tasks also include, where required, routine dam safety reviews (DSR), upgrades to operation, maintenance and surveillance manuals, emergency preparedness and response plans, public safety plans as well as other regularly scheduled tasks. This operational plan will be updated as required to address a material change to flood or erosion control infrastructure, or when there is a safety review or conditions assessment that results in changes to its operations.

3 Background

3.1 HCA Infrastructure

The flood and erosion control infrastructures that HCA operates are the Christie Lake Dam, Valens Lake Dam and Mineral Springs detention reservoir, and Saltfleet wetland berms (BC-1).

The Christie Lake Dam is located on Spencer Creek, upstream of Dundas within the Christie Lake Conservation Area. Constructed in 1972, the dam provides flood control and low flow augmentation. In addition, the dam reservoir provides recreational opportunities and fish habitat. Christie Lake Dam consists of the following components:

- A 109 m long concrete dam with Ogee emergency spillway with the crest elevation at 235.93 m. At the top of the spillway, 0.60 m high (total) flashboards are installed, which can be removed in case of a major flood.
- A control structure consisting of two Ogee spillways with the crest elevation at 231.65 m, controlled by two 4.88 m wide 4.88 m high radial gates or 1.52 m high steel panels during the winter. The maximum opening of the radial gates is 3.66 m.

- A drop inlet structure containing three 1.83 m wide stop log controlled bays, two 0.6 m x 0.6 m gate valves, and a 0.15m diameter low flow valve. The stop log bays have a sill elevation of 234.48 m. 0.53 m high (total) stop logs are installed in each bay during summer. The gate valves have an invert elevation of 229.52 m. The low flow valve has an invert elevation of 231.50 m.
- Earth embankments as the abutments.

The Valens Lake Dam is located on Spencer Creek, near the community of Valens, Ontario within the Valens Conservation Area. Constructed in 1966, the dam provides recreational opportunities and fish habitat, but does also provide some flood control. The dam consists of the following components:

- A 121.9 m long earth-fill embankment with a crest elevation at 277.3 m and a toe elevation of 270.8 m.
- The dam has a concrete overflow culvert with a drop inlet. The concrete drop inlet spillway has the crest elevation at 274.64 m. Stoplogs can be placed in the concrete drop inlet structure to raise the water level up to 275.25 m.
- A square low-level intake (0.91 m by 0.91 m) is controlled by a 0.36 m diameter valve. The invert elevation of the intake is 270.80 m.

The Mineral Springs detention reservoir is located on Sulphur Creek and created as a result of the crossing at an unpaved section of Martin Road. The Martin Road section representing the embankment is 240 m long with a weir crest protected by concrete over a length of 30 m. The crest elevation of Martin Road at the low point for the crossing is 188.46 m. A riser pipe inlet is included on a 0.60 m diameter culvert. The invert elevation of the culvert is 183.50 m. Unlike the other three infrastructures, the Mineral Springs detention reservoir is designed to overtop Martin Road for storm events near and larger than the 10-year design storm.

The Saltfleet wetland berms (BC-1) are two separate wetland containment berms (East and West) that are located in HCA's Saltfleet Conservation Area at 444 First Road East. The BC-1 East and West wetlands are part of the larger Saltfleet wetlands system, that will include several locations along Battlefield Creek and Stoney Creek. The BC-1 East and West wetlands provide flood and erosion control as well as low flow augmentation to downstream reaches of Battlefield Creek. The Saltfleet wetland berms (BC-1 East and West) each consist of a clay core earth berm, with an outlet structure and emergency spillway. Each outlet structure consists of a riser pipe and a corrugated steel culvert through the berm. The berm crest elevations of the East and West berms are 189.27 m and 188.86 m respectively. The East berm steel culvert is 1.00 m diameter, with an invert elevation of 187.62 m. The West berm steel culvert is 0.70 m diameter, with an invert elevation of 187.34 m.

3.2 Regulatory Framework and Dam Safety

Of the HCA flood and erosion control infrastructure, Christie Lake Dam and Valens Lake Dam are regulated by the Ministry of Northern Development, Mines, Natural Resources and Forestry (MNR) under the Lakes and Rivers Improvement Act.

These are subject regulations under the act including Ontario Regulation 454/96 Construction and the associated technical bulletins and best management practices. The regulation requires, where appropriate, regular safety reviews and hazard potential classification (HPC) assessments. The hazard potential classification is made based on several criteria including life safety, property losses, environmental losses and cultural – built heritage losses. Table 3-1 summarizes the maximum years between DSRs or HPCs from the LRIA guidance documents.

Table 3-1– Dam Safety Review Periods

Hazard Potential Classification Category	Review period
Very High and High	Maximum 10 years between DSR or earlier if specified by current dam safety review, or less
Low and Moderate	Maximum 10 years between HPC re-assessments, or less

HCA also operates these two infrastructures according to guidelines and best management practices for public safety around dams established by the Canadian Dam Association.

As such, for Christie Lake Dam and Valens Lake Dam, regular dam safety reviews (DSR), upgrades to operation, maintenance, safety and surveillance manuals (OMSS), emergency preparedness and response plans (EPRP), public safety plans (PSP) are completed.

The Mineral Springs detention reservoir and Saltfleet wetland berms (BC-1) do not meet the definition of a dam as per the LRIA and are not subject to the same regulations as the Christie Lake and Valens Lake dams. Thus, DSR, OMSS, EPRP, and PSP are not completed for these two infrastructures.

4 Flood and Erosion Control Infrastructure Management Program

The management program for HCA's four flood and erosion control infrastructure includes where appropriate the following:

- Routine Visual Inspections
- Formal Inspections
- Dam Safety Reviews
- Operation, Maintenance, Safety and Surveillance Plans (OMSS) Updates
- Emergency Preparedness and Response Plans (EPP) Updates
- Public Safety Plan (PSP) Updates
- Regular repairs and preventative maintenance

4.1 Inspection Program

4.1.1 Routine Visual Inspections

Routine visual inspection assesses dam conditions, and involves examination of key components of the dam. These are undertaken for all four flood and erosion control infrastructure by the HCA staff each time they visit the site to undertake operations or inspection or at a minimum on a at most monthly basis.

Routine visual inspections also include observable signs of the trespass, fishing activity from/near the dam and vandalism.

Details of any deficiencies are reported to the dam engineering team for required follow up with special inspection if warranted.

Moving forward, monthly inspections by HCA water resources engineering staff will also be completed for all four flood and erosion control infrastructure. These inspections will focus on structural conditions, as well as indications of significant seepage, sloughing, settling, or surface erosion.

4.1.2 Formal Inspections

Formal inspections are intended to be a thorough inspection by HCA water resources engineering staff, completed annually as well as in special situations.

Moving forward, annual inspections will be completed for all four flood and erosion control infrastructure.

Special formal inspections are required at the discretion of HCA water resources engineering staff, or dam operators (park superintendents or assistant superintendents)

after a significant flood, earthquake, rapid snowmelt, heavy rainfall or other severe weather.

4.1.3 Dam Safety Review (DSR)

Dam Safety Review (DSR) are routinely completed for the Christie Lake dam and Valens Lake dam.

A DSR is a systematic evaluation of the safety of the dam, by means of comprehensive inspection of the structures, assessments of dam performance with a review of basic features and design assumptions. It generally involves the collection of all available records, field inspection, detailed investigation and possible laboratory testing. The DSR is completed by independent engineers qualified by their background and experience in the design, construction and performance evaluation and operation of dams. Typically, the inspection is required every 5 to 10 years. It also assesses the hazard potential classification and provides recommendations for further inspections and maintenance.

4.2 Operation, Maintenance and Surveillance and Safety Manual Updates

Operation, Maintenance and Surveillance and Safety (OMSS) manuals have been developed and are updated as required for the Christie Lake dam and Valens Lake dam.

The OMSS manual is also referred to the Operation, Maintenance and Safety (OMS) manual. The OMSS manual is a compilation of information used to operate, maintain and monitor the condition of the dams to ensure safe operation. The manual assists the operator(s) to follow HCA and Occupation Health and Safety Act standard procedures. It includes information on the:

- Organizational structure
- Duties and Responsibilities
- Emergency Contact information
- Required Training

It provides a summary of the dam structure, spillway and outlet details and summarizes optimal seasonal operating conditions, water levels, as well as gate and valve settings. It also describes the equipment and the operating instructions on how to adjust the gates as well as record keeping and documentation of the annual and routine visual inspections. The OMSS manual is updated each time there is a DSR or earlier if there are any changes to regular operations.

The most current OMSS manuals are found in Appendix A.

4.3 Emergency Preparedness and Response Plans Updates

Emergency Preparedness and Response Plans (EPRP) have been developed and are updated as required for the Christie Lake dam and Valens Lake dam.

The EPRP addresses potential emergency situations and outlining appropriate response measures.

A comprehensive EPRP ensures that all parties responsible for water control along the watershed are involved in an action plan to ensure the safety of the public in the event of a dam emergency. Specifically, this plan is intended to allow the dam operator (or other designated staff) to clearly identify what constitutes an emergency situation. The EPRP manual is updated each time there is a DSR or earlier if there are any changes to regular operations.

The most current EPRPs are found in Appendix B.

4.4 Public Safety Plans Updates

Public Safety Plans (PSP) have been developed and are updated as required for the Christie Lake dam and Valens Lake dam.

PSPs summarize the hazards associated with the dam and its operations. It describes risk associated with the hazards and recommends control measures to eliminate or reduce the risk of public injury or death during operations. It also outlines roles, responsibilities, procedures and timelines that are required in order for the HCA to demonstrate public safety due diligence. The PSP are prepared in accordance with the Canadian Dam Association (CDA) Guidelines for Public Safety Around Dams and considers the Best Management Practices for Public Safety Around Dams. The most current PSPs are found in Appendix C.

4.5 Repairs and Preventative Maintenance

Routine repairs and preventative maintenance are completed as required at the four flood and erosion control infrastructure. The preventative maintenance or repairs may be required from results of, the inspection programs, manual and plan updates, or the asset lifecycle management.

5 Infrastructure Specific Operations

5.1 Christie Lake Dam Operations

Previous DSR have assessed the Hazard Potential Classification of this dam as “Very High”. The OMSS and EPRP provides the information and procedures required for on-site operation of the dam. In general, the operator and HCA Manager of Water Resources Engineering are responsible for operating the dam in normal and emergency conditions, safety, and performance monitoring. The most recent OMSS and EPRP plans containing detailed procedures for Christie Dam can be found in Appendix A.1 and B.1.

5.1.1 Operating conditions

Under normal conditions, operations are required approximately 4 times a year, with the purpose of maintaining water levels at the appropriate levels at or near the target water level for each season. In winter, steel panels are placed in the sluiceways to alleviate ice pressure on the radial gates. Water levels are routinely adjusted during snowmelt and rainfall events by operating the radial gates, gate valves, and low flow valve.

Under flooding, extreme flood emergency, or unexpected natural disaster conditions, the dam operator and HCA Manager of Water Resources Engineering need to monitor the weather, reservoir water levels and the dam as required in order to maintain the reservoir water level as constant as possible and within the operating ranges for the various periods. The OMSS and EPRP manuals provide guidelines for dam opening and closing procedures, before and after rainfall and snow melt events. Additionally, it relies on the dam operator and HCA Manager of Water Resources Engineering experience and judgement based on historical operation.

During periods of low flow, the dam operator and HCA Manager of Water Resources Engineering must ensure a minimum discharge from the dam by opening the low flow valve, or by allowing leakage through or removing stop logs.

5.1.2 Operating procedures

The OMSS details the step by step procedures for operational activities at Christie Lake Dam. The following are regular operational activities for the Dam:

1. Radial gates are operated by the control panel located in the control building. The gates can be operated manually in case of emergency conditions when there is no electrical power.
2. An overhead gantry system is used to install steel panels during winterization of the dam. The panels are hoisted from the storage area and lowered into place. They are removed in the spring so radial gates can perform as normal.
3. Valves are controlled by a hand wheel to raise and lower gate valves and low flow valves.

4. Ice and Debris removal should be done as required to allow unobstructed flow.
5. Maintenance on concrete and earth structures, vegetation control, instrumentation maintenance and repairs and low flow valve maintenance and repairs.

HCA holds a permit to take water to operate the Christie Lake Dam and reservoir. The quantity is limited to 24,670 m³/day, however more is allowed to be retained to manage flows downstream as required for flood management.

5.1.3 Documentation and record keeping

Documentation is completed to keep a record of dam operating, inspection and maintenance activities.

5.2 Valens Lake Dam Operations

Previous DSR have assessed the Hazard Potential Classification of this dam as “Very High”. The OMSS and EPRP provide the information and procedures required for on-site operation of the dam. In general, the operator and HCA Manager of Water Resources Engineering are responsible for operating the dam in normal and emergency conditions, safety, and performance monitoring. The most recent OMSS and EPRP plans containing detailed procedures for Valens Dam can be found in Appendix A.2 and B.2.

5.2.1 Operating Conditions

Under normal conditions, changes to the stoplogs and valve settings are required approximately twice a year (in the Spring and Fall). In addition, water levels are occasionally adjusted during and after snowmelt and rainfall events by operating the low flow valve. The purpose is to adjust the water levels to the target water level for each season.

Under flooding, extreme flood emergency, or unexpected natural disaster conditions, the operator and HCA Manager of Water Resources Engineering need to monitor the weather, reservoir water levels and the dam as required in order to maintain the reservoir water level as constant as possible, and within the operating ranges for the various periods. The OMSS and EPRP manuals provide guidelines for dam opening and closing procedures, before and after rainfall and snow melt events. Additionally, it relies on the operator and HCA Manager of Water Resources Engineering experience and judgement based on historical operation.

During periods of low flow, the dam operator and HCA Manager of Water Resources Engineering must ensure a minimum discharge from the dam by opening the low flow valve, or by allowing leakage through or removing stop logs.

5.2.2 Operating procedures

The OMSS and EPRP details the step by step procedures for operational activities at Valens Dam. The following are typical operational activities for the Dam:

1. Stoplog manipulation is carried out by hand. The procedure is completed from the dam deck of the drop inlet structure and safe working practices are employed. Stoplogs can be lifted out to adjust flow to target levels. In the event of rapid rising water levels, the chains connected to the steel stanchions that hold the stoplogs can be lifted with a front-end loader to increase discharge capacity.
2. The low flow valve is operated by turning the stem located on the crest of the control structure.
3. Removal of debris may be required as it can accumulate at the stoplog bay and on top of the drop inlet structure. The debris must be removed to allow unobstructed flow.
4. Maintenance on concrete and earth structures, vegetation control, instrumentation maintenance and repairs and low flow valve maintenance and repairs.

HCA holds a permit to take water to operate the Valens Dam and reservoir. The quantity is limited to 40,300 m³/day, however more is allowed to be retained to manage flows downstream as required for flood management.

Under low water conditions, stoplogs may require sealing of joints to reduce leakage between the logs. During very dry summers, the target level is difficult to maintain. Plastic sheeting is placed along the upstream face of the stoplogs to avoid further water loss by leakage.

5.2.3 Documentation and record keeping

Documentation is completed to keep a record of dam operating, inspection and maintenance activities.

5.3 Mineral Springs Detention Reservoir

HCA entered into an easement/maintenance agreement with the town of Ancaster (City of Hamilton) for the Mineral Springs detention reservoir. The town agreed to maintain and repair the detention reservoir in accordance with accepted engineering practice and as outlined in the operation, maintenance and safety manual, while HCA is responsible for Capital Works to the embankment and culvert structure. It is understood that the City of Hamilton owns Martin Road as well as the embankment and culvert structure; while HCA owns the land upstream of the road which is used as flood detention storage.

5.3.1 Operating Conditions

Flows are not actively controlled by any mechanism or valve. Flows are self-regulatory via the culvert outlet, therefore there are no specific operation procedures. Maintenance

for this dam involves checking for blockages and making any observations on the dam structure.

5.3.2 Documentation and record keeping

Regular maintenance is the responsibility of the City of Hamilton, however as part of due diligence HCA also monitors the detention pond and maintains a record of inspection and maintenance activities. Saltfleet Wetland Berms (BC-1)

5.3.3 Operating Conditions

Flows at the BC-1 are not actively controlled by any mechanism or valve. They are self-regulatory via the riser pipe and culvert outlet structure, therefore there are no specific operation procedures. The current operating procedures for this berm are to complete post-construction monitoring. Maintenance involves minor repairs such as regrading the surface as required.

5.3.4 Documentation and record keeping

Documentation is completed to keep a record of dam inspection and maintenance activities.

6 Summary of Operational Program Tasks from 2000 – 2023

A summary of recent reports from the completed operational tasks at each dam are presented in Table 6-1 through Table 6-4. These tables include major operational activities and are not inclusive of all dam maintenance and rehabilitation works and reports. Refer to Appendix A for current operation and maintenance manuals, Appendix B for current emergency preparedness plans, and Appendix C for current public safety plan.

6.1 Christie Lake Dam

Table 6-1 - Christie Lake Dam Operational Tasks Summary

Task/Report	Year	Key Points
Christie Dam Study of Maintenance Requirements (KST Hydroelectric Engineers)	2000	<ul style="list-style-type: none"> • Rated overall dam condition to be fair-to-good • Identified deficiencies • Recommendations for further investigation and areas to be rehabilitated
Christie Lake Dam Break Analysis (Klohn Crippen)	2005	<ul style="list-style-type: none"> • Identified Christie Lake Dam a High Hazard Potential Classification
Operations, Maintenance, Surveillance and Safety (OMSS) Manual (Klohn Crippen)	2005	<ul style="list-style-type: none"> • Updated Manual for operating under regular conditions
Emergency Preparedness Plan (EPP) Manual (Klohn Crippen)	2005	<ul style="list-style-type: none"> • Outlined procedures for emergency situations
Dam Inspection and Assessment (exp.)	2013	<ul style="list-style-type: none"> • Dam safety review • Identified Christie Lake Dam a Very High Hazard Potential Classification • Identified several deficiencies in existing conditions
OMSS Manual (exp Services Inc.)	2013	<ul style="list-style-type: none"> • Updated manual for operating under regular conditions
EPP Manual (exp Services Inc.)	2013	<ul style="list-style-type: none"> • Updated procedures for emergency situations
Public Safety Measures Plan (PSMP) (exp.)	2015	<ul style="list-style-type: none"> • Identified potential hazards • Completed risk assessment • Recommended procedures and mitigation measures to manage risks

Christie Lake Dam Public Safety Risk Assessment (D.M. Wills Associates Limited)	2021	<ul style="list-style-type: none"> Identified potential hazards Review of existing public safety measures Recommended public safety measures
Public Safety Plan (D.M. Wills Associates Limited)	2022	<ul style="list-style-type: none"> Summarized hazards identified in risk assessment Defines roles, responsibilities, procedures and timelines for due diligence Recommended to continue update of public safety plan update every 5 years (keep records for minimum 10 years)
Dam Safety Review (GHD)	2024	<ul style="list-style-type: none"> Dam safety review as required by LRIA
OMSS Update (GHD)	2024	<ul style="list-style-type: none"> Updated manual for operating under regular conditions
Emergency Preparedness and Response Plan (GHD)	2024	<ul style="list-style-type: none"> Updated procedures for emergency situations

6.2 Valens Lake Dam

Table 6-2 - Valens Lake Dam Operational Tasks Summary

Task/Report	Year Completed	Key Points
Valens Dam Stability and Safety Assessment (Acres International)	2004	<ul style="list-style-type: none"> Identified that the Hazard Potential Classification is High Defined the probable maximum flood Defined design basis earthquake Identified some deficiencies and provided recommendations for remediation
Operations, Maintenance, and Surveillance (OMS) Manual (Klohn Crippen)	2005	<ul style="list-style-type: none"> Updated manual for operating under regular conditions
Dam Break Analysis (exp.)	2011	<ul style="list-style-type: none"> Estimated flood flows Confirmed Hazard Potential Class Very High Mapped dam break flood inundation Confirmed design earthquake return period
OMSS Update (exp.)	2013	<ul style="list-style-type: none"> Updated manual for operating under regular conditions
EPP Update (exp.)	2013	<ul style="list-style-type: none"> Defined roles and responsibilities during emergency situation Outlined procedures for emergency situations
Dam Safety Review (exp.)	2015	<ul style="list-style-type: none"> References the Dam Break Analysis report (exp, 2011) with additional investigations Identified deficiencies Provided recommendations to address issues
Public Safety Measures Plan (PSMP) (exp.)	2015	<ul style="list-style-type: none"> Summarized hazards Provided recommended measures/procedures to mitigate Recommended update of public safety measures plan every 5 years

Task/Report	Year Completed	Key Points
Public Safety Risk Assessment (D.M. Wills Associates Limited)	2021	<ul style="list-style-type: none"> • Identified potential hazards • Review of existing public safety measures • Recommended public safety measures
Public Safety Plan (D.M. Wills Associates Limited)	2022	<ul style="list-style-type: none"> • Summarized hazards identified in risk assessment • Defines roles, responsibilities, procedures and timelines for due diligence • Recommended to continue update of public safety plan update every 5 years (keep records for minimum 10 years)
Dam Safety Review (Tulloch Engineering)	2021	<ul style="list-style-type: none"> • Recommended to continue routine DSR every 5 years for very high HPC dams • Identified deficiencies • Provided recommendations to address issues • Recommended update to OMSS and EPP
OMSS Update (GHD)	2024	<ul style="list-style-type: none"> • Updated manual for operating under regular conditions
Emergency Preparedness and Response Plan	2024	<ul style="list-style-type: none"> • Updated procedures for emergency situations

6.3 Mineral Springs Detention Reservoir

Table 6-3 - Mineral Springs Detention Reservoir Operational Tasks Summary

Task/Report	Year Completed	Key Points
Operation Inspection Maintenance Manual	1992	<ul style="list-style-type: none"> • Summarized inspection requirements
Structural Assessment (Hatch)	2010	<ul style="list-style-type: none"> • Identified the level of hazard potential class to be low in condition at the time • Provided potential remedial options with cost estimates for each
Peer Review (exp)	2012	<ul style="list-style-type: none"> • Reviewed previous reports from 1988 – 2010 • Identified information gaps and made recommendations including additional studies and assessments

6.4 Saltfleet Wetland Berms

Table 6-4 – Saltfleet Wetland Berms Operational Tasks Summary

Task/Report	Year Completed	Key Points
BC-1 Wetland Berm Construction	2022	<ul style="list-style-type: none">• Major construction completed in 2022.

This page intentionally left blank.

7 Upcoming Operational Tasks

Inspections are planned to continue consistent with the details provided in Section 4.1. Routine operations are planned to continue consistent with the details provided in Section 5.

In response to findings from previous Dam Safety Reviews and Public Safety Risk Assessments, as well as routine dam inspections by internal staff, HCA will continue to complete necessary maintenance and repair works. The schedule for completion of necessary proactive maintenance/repair works is dependent on the nature and magnitude of the maintenance or repair. The appropriate schedules are confirmed with Professional Engineers. The repair designs are completed, as necessary, by external Professional Engineers.

As Christie Lake Dam and Valens Lake Dam are regulated by MNRF under the Lakes and Rivers Improvement Act, regular updates to the following are scheduled as per Table 7-1.

Table 7-1 - Infrastructure and Operational Review Schedule

Task/Report	Schedule	Date of Latest Review	Date of Next Review
Christie Lake Dam			
DSR	Reviewed Max. every 10 years ¹	2023	2033
OMSS Update	As required ²	2024	2033
EPRP Update	As required ²	2024	2033
PSMP Update	Reviewed at least every 5 years	2022	2027
Valens Lake Dam			
DSR	Every 5 years as per DSR	2021	2026
OMSS Update	As required ²	2024	2026
EPRP Update	As required ²	2024	2026
PSMP Update	Reviewed at least every 5 years	2022	2027

¹DSRs are completed regularly with a maximum of 10 years between reviews, unless the most recent DSR specifies a higher frequency or if owner has chosen to complete earlier.

²As recommended by DSR or with any considerable changes to the operations of the dam.

8 Appendices

Appendix A - Current Operations, Maintenance, Safety and Surveillance Plans

Appendix B - Current Emergency Response and Preparedness Plans

Appendix C - Current Public Safety Plans

APPENDIX A

Operations, Maintenance, Safety and Surveillance Plans

APPENDIX A.1

Christie Lake Dams

Operations, Maintenance, Safety and Surveillance

Preface

This Operation, Maintenance, Surveillance and Safety (OMSS) Manual contains suitable and sufficient information to allow on-site operators to:

- (a) Operate the dam under normal and emergency conditions in a safe manner.
- (b) Maintain the dam in a safe condition.
- (c) Monitor the dam's performance well enough to provide early warning of any distress.

This is not a Dam Design Manual. Detailed engineering aspects such as hydrologic analyses, hydraulic investigations, environmental studies, as-constructed drawings, and formal professional evaluations are documented in other reports and sources.

The OMSS Manual is prepared for Christie Lake Dam, which is located in the Spencer Creek Watershed. It consists of an earth embankment and a concrete control structure constructed in 1972. The Manual should be revised as necessary as site experience is acquired.

Christie Lake Dam consists of an earth embankment and a concrete structure containing two sluiceways controlled by radial gates, a drop inlet structure with three stop log bays, two gate valves and a low flow valve, and an overflow spillway. Its primary purpose is providing downstream flood control and low flow augmentation. In addition, the dam reservoir provides recreational opportunities and fish habitat.

The only dam upstream of the Christie Lake Dam is the Valens Dam, located approximately 30 km upstream of the dam.

This Manual references information provided in the reports entitled "Christie Lake Dam Safety Review (exp, 2013)" and "Emergency Preparedness Plan (EPP) for Christie Lake Dam". It is recommended that the operator(s) read and understand the Dam Safety Review report and EPP before operating the dam.

Table of Contents

1	Introduction	1
1.1	Organization Structure	2
1.2	Duties and Responsibilities	2
1.3	Training	3
2	The Dam	4
2.1	Site Access	4
2.2	Dam Watershed & Storage	4
2.3	Spillway and Outlet Works	4
2.4	Hazard Potential.....	5
2.5	Inflow Design Flood.....	5
2.6	Major Repairs and Modifications	5
2.7	Inspections	5
2.8	Known Problems and Incidents.....	5
2.9	Available Drawings.....	5
3	Objectives of Operation.....	10
4	Special Concerns, Known Problems and Constraints.....	11
5	Operational Procedures.....	12
5.1	General	12
5.2	Type One Operation (Seasonal)	12
5.2.1	General Operating Procedure.....	12
5.2.2	Fall Operation	12
5.2.3	Winter Operation.....	13
5.2.4	Spring Operation.....	13
5.2.5	Summer Operation	13
5.3	Type Two Operation (Flooding and Emergency Conditions).....	13
5.3.1	Flooding in the Summer and Fall Periods	14
5.3.2	Flooding During the Spring Snowmelt Runoff Event	15
5.3.3	Periods of Low Flow	17
6	Equipment, Tools and Safety Procedures	18
6.1	Equipment and Tools	18

6.2	Radial Gate Procedure.....	18
6.2.1	Normal Non-operating Situation	19
6.2.2	Operating Situation	19
6.2.3	Manual Operation Of Gate By Hand Drive	20
6.2.4	Manual Operation Of Gate By Self-Weights And Fan Brake.....	21
6.2.5	Manual Operation Of Gate By Emergency Power Drive	21
6.2.6	Auxiliary Items.....	22
6.3	Overhead Gantry Procedure	22
6.4	Overflow Spillway Procedures.....	23
6.5	Valve Procedures	23
6.6	Lifting Procedures	23
6.7	Jacking Procedures.....	24
6.8	Safety Around the Dam.....	24
6.9	Boom.....	24
6.10	Ice And Debris Removal.....	24
7	Inspection and Maintenance	25
7.1	Inspection.....	25
7.2	Maintenance.....	26
8	Surveillance and Performance Monitoring	28
9	Records.....	29
10	Public Safety.....	34

List of Figures

Figure 2.1. Christie Lake Dam Location.....	7
Figure 2.2. Spencer Creek Watershed	8
Figure 2.3. Reference Plan View and Sections of the Dam.....	9
Figure 9.1a. Staff Gauge.....	30
Figure 9.1b. Staff Gauge.....	31

List of Tables

Table 5.1. Gate Opening Procedure during Rainfall.....	14
Table 5.2. Closing Procedure following Rainfall	15
Table 5.3. Gate Opening Procedure during Snowmelt	15
Table 5.4. Closing Procedure following Snowmelt	16
Table 5.5. Alternate Closing Procedure following Snowmelt.....	17

Appendices

Appendix A - Record Drawings

Appendix B - Reference Photographs

Appendix C - Equipment and Tools For Dam Operators

Appendix D - Background Information

- Operating Rule Curve

Appendix E - Forms and Worksheets

- Form OMSS1 – Record Of Operations
- Form OMSS2 – Record Of Maintenance
- Form OMSS3 – Visual Inspection Form

1 Introduction

The Christie Lake Dam is located on Spencer Creek, which discharges into Lake Ontario at Hamilton Harbour, near the community of Flamborough, Ontario within the Christie Lake Conservation Area. The UTM coordinates of the Dam are 4792202 North and 580531 East, UTM Zone 17. The highest elevation of the deck is 238.66 m (approximate GSC elevation).

Geographic Township	Lot	Con.	Area Municipality	Regional/County Municipality
West Flamborough			Flamborough	Hamilton-Wentworth

UTM Zone	UTM East	UTM North	Latitude			Longitude		
			Deg.	Min.	Sec.	Deg.	Min.	Sec.
17	580531	4792202	43° N	16'	42"	80° W	0'	27"

The dam consists of an earth embankment and a concrete structure. The concrete structure consists of two sluiceways controlled by radial gates, a drop inlet structure with three stop log bays, two gate valves, and a low flow valve, and an overflow spillway. The sluiceways are 4.88m long and have a sill elevation of 231.65m (GSC datum) with 4.88m high radial gates or 1.52m high steel panels. The stop log bays are 1.83m long and have a sill elevation of 234.48 m GSC, each with 3.5-150 mm high stop logs. The gate valves are 0.6m long by 0.6 m high and have an invert elevation of 229.52 m GSC. The low flow valve is 0.15m in diameter and has an invert elevation of 231.50 m GSC. The overflow spillway is approximately 109m long and has a crest elevation of 235.93 m GSC with 0.6 m high flashboards installed at the crest.

This OMSS Manual is a compilation of information used to operate, maintain and monitor the condition of the Christie Lake Dam to ensure safe operation. The objectives and procedures are outlined in this Manual and the recording forms are provided in Appendix E. The dam should be operated, maintained and inspected regularly to ensure the safety of the dam, in accordance with the Lakes and Rivers Improvement Act (LRIA) Technical Guidelines and Best Management Practices (MNR, 2011). This Manual was prepared to assist the operator(s) to follow the Hamilton CA and Occupation Health and Safety Act standard procedures.

This Manual does not address all possible circumstances that might provide a threat to the safety or integrity of the dam and related facilities. At least two (2) operators must attend the site. The operator(s) is required to evaluate and report circumstances causing potential concerns for safety, and to implement appropriate corrective actions including operational, maintenance, and remedial measures.

An Emergency Preparedness Plan (EPP), addressing potential emergency situations and outlining appropriate response measures, was prepared and issued under separate cover.

This Manual should be updated as necessary. Additional information, changes in procedure, or other amendments to operating or maintenance practices affecting dam safety should be incorporated into this Manual.

1.1 Organization Structure

The Christie Lake Dam is owned by the Hamilton Conservation Authority (HCA). It is operated by HCA staff.

HCA is responsible for the dam. All maintenance, operations, and inspections of the structure are carried out in consultation with HCA.

1.2 Duties and Responsibilities

The dam is a HCA asset, and the HCA Manager of Water Resources Engineering accepts full responsibility for the structure.

The HCA Responsibilities:

- Maintenance
- Operation
- Surveillance
- Inspection
- Training of all personnel involved in dam operations

The Operator's Responsibilities:

- Ensuring that the equipment for dam operation, public safety, communication, etc. are well maintained and in working condition, and supplies and materials needed in an emergency situation are sufficient and placed in an appropriate location or are readily available from local suppliers.
- Ensuring that suitable records of dam-related activities are prepared.
- Ensuring that access to the site is maintained.
- Ensuring the safe operation of the dam.
- Identifying emergency conditions and taking appropriate action.
- Notifying the HCA Manager of Water Resources Engineering of defects, vandalism and unusual conditions observed on the dam structure, associated components and equipment.
- Performing routine surveillance of the dam.
- Making routine inspections of the dam for potential problems (e.g. dam body, concrete conditions, spillway, foundations, seepage and sign of failure, etc).
- Notifying anyone immediately downstream of the dam who may be in immediate danger when emergency conditions occur.
- Ensuring that there is no public access to the restricted areas.
- To be familiar and trained in EPP and HCA Response Plans.
- To be familiar and trained in all environmental parameters affiliated with the dam and watercourse (for example, Species At Risk (SAR) in the area).

1.3 Training

Operator training should be undertaken both on a regular basis and by request. New operators should be trained in the following:

- Operational procedures
- Safety requirements
- Minor maintenance of the structure
- Proper use of tools and equipment
- Data recording
- Inspection

HCA is responsible for the arrangement of operator training.

2 The Dam

2.1 Site Access

Christie Lake Dam can be accessed via Crooks Hollow Road off Highway 8. The approximate travel time is a 10 minute drive from the HCA office (838 Mineral Spring Road, Ancaster, Ontario).

Figure 2.1 shows the location of the dam.

2.2 Dam Watershed & Storage

The Spencer Creek watershed at the dam drains a total area of 153 km². The total reservoir surface area within the watershed during summer is 72 ha. The watershed has a maximum reservoir storage capacity of about 395 ha-m (3,950,000 m³) at elevation 237.44 m GSC (figures from Christie Lake Dam Safety Review, 2013).

Figure 2.3 shows the Spencer Creek watershed.

2.3 Spillway and Outlet Works

Christie Lake Dam consists of an earth embankment and a concrete structure with two sluiceways, a drop inlet structure with two sluiceways, three stop log bays, two gate valves, and a low flow valve, and an overflow spillway. The pertinent dam data and elevations are:

Concrete Structure:

- Total Length 124.4 m
- Maximum Height 9.6 m

Sluiceways:

- Number 2
- Sill Elevation 231.65 m GSC
- Length 4.88 m (16 ft)
- Radial Gates Height 4.88 m (16 ft)
- Steel Panels Height 1.52 (5 ft)

Stop Log Bays:

- Sill Elevation 234.48 m GSC
- Length 1.83 m (6 ft)
- Stop Log Height 0.152 m (6")
- Number of Logs per Bay 3.5

Gate Valves:

- Number 2
- Invert Elevation 239.52 m GSC
- Dimensions 0.61 m x 0.61 m (2 ft x 2 ft)

Low Flow Valve:

- Invert Elevation 231.50 m GSC
- Diameter 0.15 m (6")

Water Level Gauges Location:

- Imperial gauge on the south wingwall, upstream side

Figure 2.2 shows reference plan and sections of the dam.

2.4 Hazard Potential

The Hazard Potential Classification for the Christie Lake Dam was determined to be VERY HIGH in the Dam Safety Review completed by **exp** in 2013.

2.5 Inflow Design Flood

The Dam Safety Review (**exp**, 2013) determined the Inflow Design Flood (IDF) for the Christie Lake Dam to be the Probable Maximum Flood (PMF), as per the LRIA Technical Bulletins (2011).

2.6 Major Repairs and Modifications

The Main Dam was constructed in 1972.

Repairs/maintenance to the dam was completed in 2005, including the following:

- Installation of an overhead gantry system with fall arrest system, and steel panels over sluiceways
- Repairs to the service gains
- Installation of a low flow valve
- Concrete and construction joints repairs and rust removal
- Installation of new handrails and radial gate hoist covers
- Installation of a safety boom upstream
- Repairs to the gate valves

2.7 Inspections

The most recent formal inspection of the dams took place in July 2011, by **exp**.

2.8 Known Problems and Incidents

See Section 4.0 Special Concerns, Known Problems and Constraints

2.9 Available Drawings

The following drawings are available:

- Construction drawings dated Jan. 24, 1968
- As-built drawings dated July 2005

The Christie Lake Dam drawings (Reference Plan and Section, 1968 and Site & Dam Plan, 2005) are provided in Appendix A. The following information for the dam is also provided in Appendix D:

- Operational Rule Curve

Figure 2.1. Christie Lake Dam Location

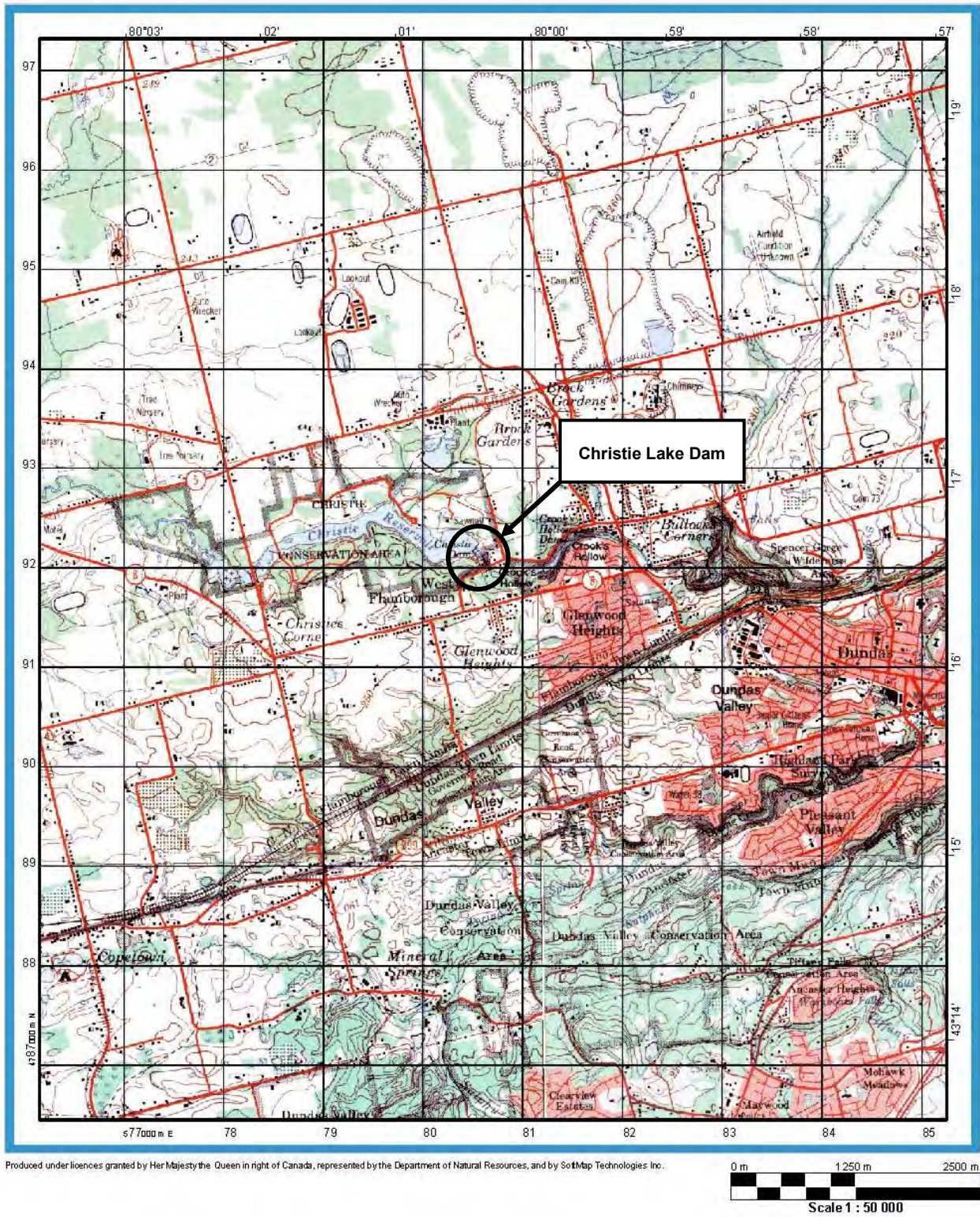


Figure 2.2. Spencer Creek Watershed

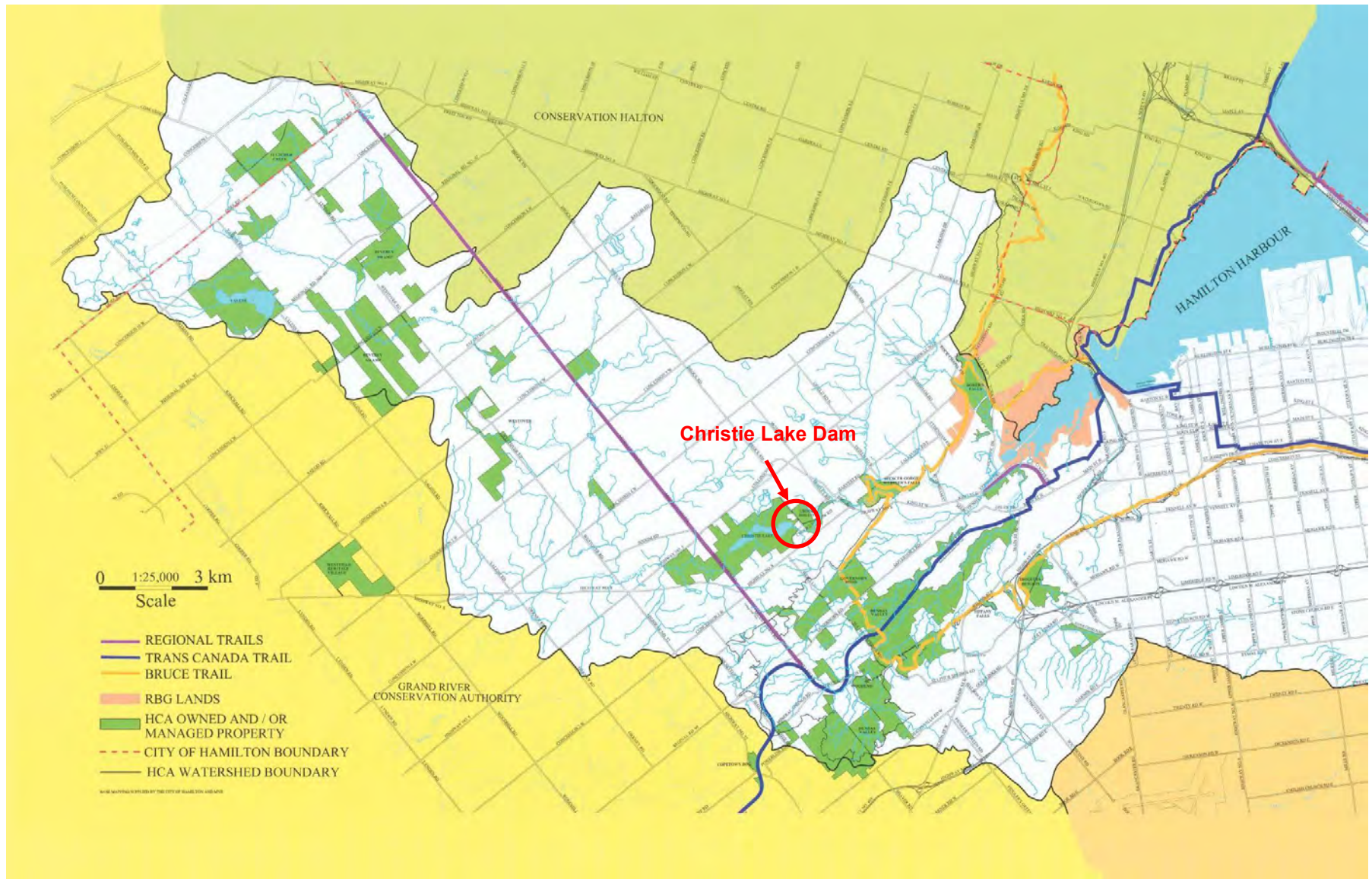
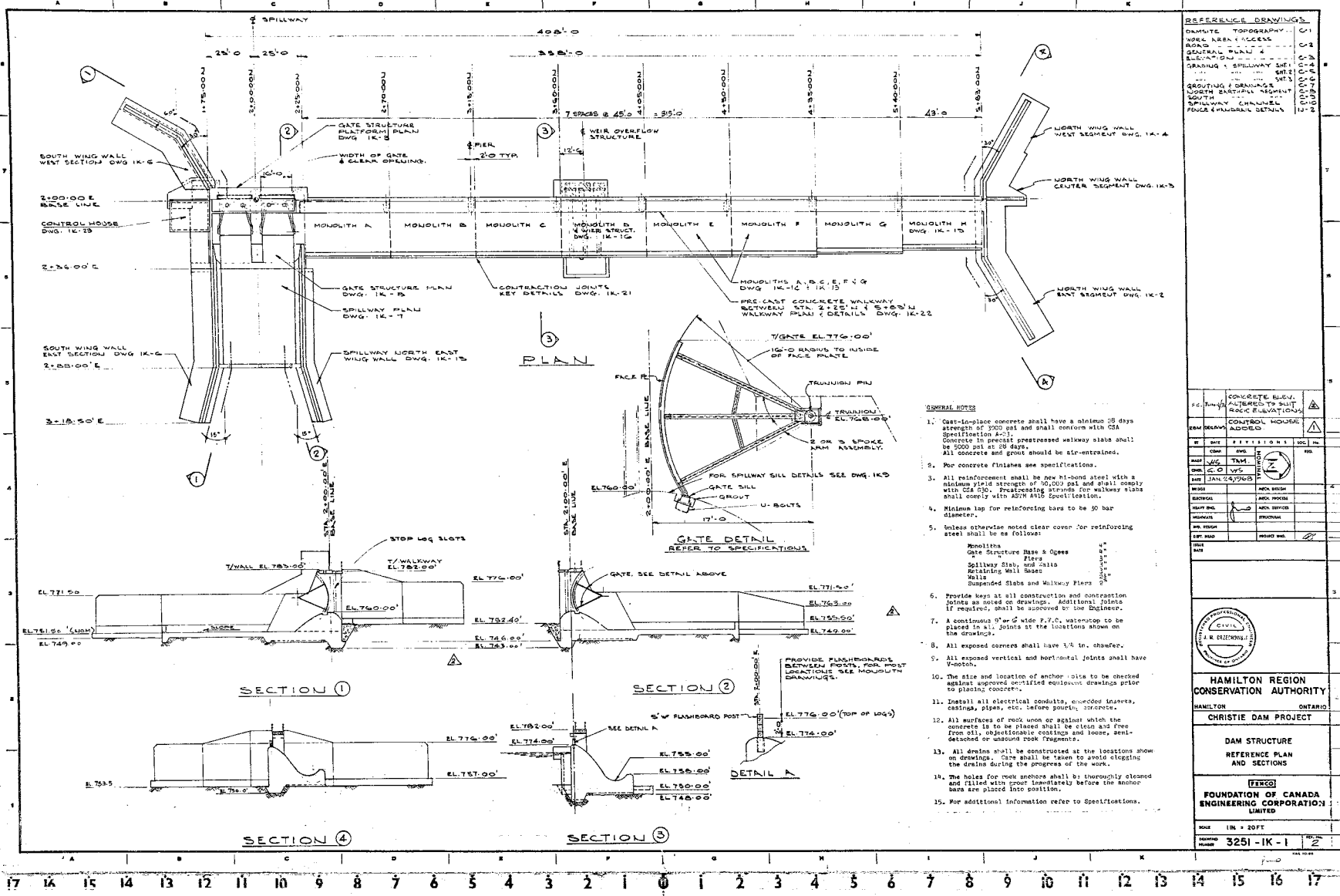


Figure 2.3. Reference Plan View and Sections of the Dam



3 Objectives of Operation

The objectives of the operation of the Christie Lake Dam are:

1. Minimize water level fluctuations on the reservoir.
2. Control discharges from the dam by radial gate, stop log and valve operations throughout the year.
3. To ensure dam operator safety.
4. Provide downstream flood control benefits by storing water on the reservoir.
5. Ensure the safety of the dam and the potentially affected areas under flood conditions.
6. Maintain records of the water levels, stop log operations, discharges and the dam condition.

4 Special Concerns, Known Problems and Constraints

Lake Use

The dam is located within the boundaries of the Christie Lake Conservation Area.

Public Safety

Public access to the dam site is not restricted. The dam deck is part of a trail system. The Christie Reservoir is used for recreational activities.

No incidents of vandalism have been reported at the dam.

5 Operational Procedures

5.1 General

Two types of operations are required for the Christie Lake Dam.

1. **Type One Operation (Seasonal)**
Maintain the target lake water level on a seasonal basis, as outlined in Section 5.2.
2. **Type Two Operation (Flooding and Emergency Conditions)**
Operate the dam under emergency conditions when flooding, extreme flood emergency or other unexpected natural disasters occur. These operational procedures are described in Section 5.3.

5.2 Type One Operation (Seasonal)

5.2.1 General Operating Procedure

Under normal conditions, operations are required approximately 4 times a year during the different seasons. The purpose of the operations is to maintain the reservoir water levels at or near the target water level for the different seasons. A year can be divided into 'Fall', 'Winter', 'Spring' and 'Summer' seasons. Each period has different target water levels and hence the dam needs to be operated accordingly.

Water levels are routinely adjusted during snowmelt and rainfall events by operating the radial gates, gate valves, low flow valve, and stop logs. The stop logs will be removed and replaced by hand when necessary.

The target water levels at the Christie Lake Dam are as follows:

Season	Date	Target Water Level (Gauge Reading) m GSC
Spring	April 15 – May 1	234.71
Summer	May 15 – Sept 1	235.01
Fall	Sept 15 – Oct 15	234.71
Winter	Nov 15 – March 15	233.17

Refer to Section 9, Figures 9.1a and 9.1b. Staff Gauge for key water levels.

5.2.2 Fall Operation

Around September 1, the winter drawdown of the reservoir begins by removing 2 stop logs from each drop inlet bay. The water level is decreased and maintained at 234.71 m GSC by allowing flow through the drop inlet bays until October 15.

5.2.3 Winter Operation

Starting September 15, the steel panels are placed in the sluiceways to alleviate ice pressure on the radial gates. All the stop logs are removed from the drop inlet bays. The water level is decreased and maintained at 233.17 m GSC until March 15 by leaving the radial gates 0.3m open.

The reservoir water level should not be decreased below elevation 233.17 m in advance of the ice break-up, as it could break the ice sheet on the reservoir. An ice sheet helps protect the dam from upstream ice and reduces the potential damage that could be caused by passing pieces of ice through the dam.

The gate valves and the low flow valve remain closed during the winter months.

5.2.4 Spring Operation

Around March 15, 1.5 stop logs are placed in each drop inlet bay to increase the water level to 234.71 m GSC. This level is maintained until April 15. During this time, the Radial Gate 1 may be left open 0.3m and the Radial Gate 2 may be left open 0.45m to avoid excessive reservoir level fluctuations.

After the spring freshet around April 15, the radial gates are closed and the steel panels are removed from the sluiceways. All stop logs are placed in the drop inlet bays to achieve the summer target level of 235.01 m GSC by May 15.

5.2.5 Summer Operation

The summer target level of 235.01 m GSC is maintained throughout the summer. The low flow valve is opened to provide the regulated base flow of 0.11 cms to the downstream reach.

5.3 Type Two Operation (Flooding and Emergency Conditions)

Flooding resulting from rainfall events may occur in late spring, summer or early fall. In addition, flooding may occur from snowmelt or snowmelt plus rainfall events during the spring freshet. The dam operator needs to monitor the weather, reservoir water levels and the dam as required in order to maintain the reservoir water level as constant as possible, and within the operating ranges for the various periods.

Operations during flood conditions should be undertaken by monitoring the reservoir water levels and the weather forecasts closely, in order to determine the correct actions needed. For example, when the reservoir reaches a level whereby the gates should be opened and the forecast indicates that more rain is expected to fall, opening the gates would be the correct action. However, if no rainfall is expected, then the gates may not have to be opened since the reservoir level may stabilize and start to recede. Note that the magnitude of gate opening should not be based solely upon weather forecasts. The

dam operator needs to use his or her own judgment based on historical operations and experience as to when and how to operate the dam.

If the reservoir water level rises to elevation 235.32 m GSC, advise the community of Flamborough to close Middletown Road, which crosses the reservoir upstream of the dam.

Downstream flooding due to operation of the dam must also be considered.

5.3.1 Flooding in the Summer and Fall Periods

In the summer and fall periods, the dam is to be operated to respond to severe rainfall events to maintain target reservoir water levels for recreation purposes. The dam operator needs to use his or her own judgment based on historical operations and experience as to when and how to operate the dam.

The following tables should be used as a guideline for operation during a summer or fall rainfall event. Table 5.1 summarizes the gate opening procedure during a rainfall event and Table 5.2 summarizes the gate closing procedure following a rainfall event.

Before opening the gates, the stop logs from the drop inlet bays are removed.

Table 5.1. Gate Opening Procedure during Rainfall

Water Level Rise (m GSC)		Time Duration (min.)	Operation	Total Gate Opening (m)
From	To			
234.71	235.01	Less than 45	Open both gates 0.3m	0.3
235.01	235.32	Less than 45	Open both gates another 0.3m	0.6
235.32	235.62	Less than 60	Open both gates another 0.3m	0.9
235.62	235.93	Less than 60	Open both gates another 0.3m	1.2
235.93	236.23	Less than 60	Open both gates another 0.6m	1.8
236.23	236.53	Less than 60	No action, spillway overtops	1.8
236.53	236.83	Less than 90	Open both gates another 0.6m	2.4
236.83	237.14	Less than 90	Open both gates another 0.6m	3.0
237.14	237.30	Less than 60	Open both gates another 0.3m	3.3
237.30	237.45	Less than 60	Open both gates another 0.3m	3.6

Note that in the event of a rapidly rising reservoir (0.3m per hour) when the water level reaches elevation 235.32 m, the chains or cables should be attached to the H posts holding the spillway flashboard without delay.

If the water level rises above elevation 237.45 m GSC, pull the flashboards one bay at a time and monitor the rise rate.

When the maximum flow has been passed over the dam, the water level is allowed to decrease to elevation 236.23 m GSC at the previously attained gate setting.

Table 5.2. Closing Procedure following Rainfall

Water Level (m GSC)	Gate Setting	Operation
235.93	More than 1.2m	Close both gates 0.6m
	Between 0.6m and 1.2m	Close both gates 0.3m
235.62	More than 1.2m	Close both gates 0.6m
	Between 0.6m and 1.2m	Close both gates 0.3m
235.32	More than 1.2m	Close both gates 0.6m
	Between 0.6m and 1.2m	Close both gates 0.3m
235.01	More than 1.2m	Close both gates 0.6m
	Between 0.6m and 1.2m	Close both gates 0.3m
234.71	Between 0.6m and 1.2m	Close both gates 0.3m
234.41	Between 0.6m and 1.2m	Close both gates 0.3m
233.10	Between 0.6m and 1.2m	Close both gates 0.3m
233.79	-	Close both gates 0.15m more
233.17	-	Close both gates 0.08m more
232.57	-	Close both gates

If at any time the reservoir level begins to increase before the closing procedure is complete, maintain the current gate setting and follow the procedure for gate opening during rainfall (Table 5.2) at the appropriate elevation.

When notified that the storm danger has passed, raise the water level to the target level by placing stop logs in the drop inlet bays.

5.3.2 Flooding During the Spring Snowmelt Runoff Event

In the spring, the dam needs to be operated to:

1. Respond to snowmelt and snowmelt plus rainfall events.
2. Prepare the dam for the summer settings.

Before the spring annual freshet, dam operations would have been carried out to prepare the dam for the spring runoff. All stop logs would have been removed from the drop inlet bays, the steel panels placed in the sluiceways, and the radial gates left open 0.3m, to lower the reservoir water level to elevation 233.17 m GSC.

The following tables should be used as a guideline for operation during a snowmelt event. Table 5.3 summarizes the gate opening procedure during a snowmelt event and Tables 5.4 and 5.5 summarize the gate closing procedure following a snowmelt event.

At any snowmelt event, both gates are left open 0.3m. The steel panels are removed from the sluiceways and the stop logs are removed from the drop inlet bays before the snowmelt event.

Table 5.3. Gate Opening Procedure during Snowmelt

Water Level Rise (m GSC)		Time Duration (hr)	Operation	Total Gate Opening (m)
From	To			
235.32	235.62	Less than 5	Open both gates 0.15m	0.45
235.62	235.93	Less than 6	Open both gates another 0.15m	0.6
235.93	236.23	Less than 8	Open both gates another 0.15m	0.75
236.23	236.53	Less than 8	No action, spillway overtops	1.2
235.93	236.23	Less than 60	Open both gates another 0.6m	1.8
236.23	236.53	Less than 60	No action, spillway overtops	1.8

If the reservoir level continues to increase to elevation 236.53 m GSC and above, follow the procedure for gate opening during a rainfall event (Table 5.1).

If the reservoir level starts to decrease after reaching a higher level, follow the procedure for gate closing following a snowmelt event (Table 5.4) or the alternate procedure for gate closing following a snowmelt event (Table 5.5).

Table 5.4. Closing Procedure following Snowmelt

Water Level (m GSC)	Gate Setting	Operation
234.71	More than 0.45m	Close both gates 0.15m
234.40	More than 0.45m	Close both gates another 0.15m
234.10	More than 0.45m	Close both another gates 0.15m
233.79	More than 0.45m	Close both another gates 0.15m
233.49	More than 0.45m	Close both another gates 0.15m
233.18	More than 0.45m	Close both another gates 0.15m
232.88	More than 0.45m	Close both another gates 0.15m
	-	Close both gates and open 1 gate valve

If the reservoir level continues to decrease below 232.88 m GSC, the gate valve should be closed, the steel panels should be placed in the sluiceways and both radial gates should be opened 0.3 m.

The following procedure may be used to drawdown the reservoir following a snowmelt event, provided that Spencer Creek within the former town of Dundas is not restricted and the maximum reservoir storage is maintained.

Table 5.5. Alternate Closing Procedure following Snowmelt

Water Level (m GSC)	Gate Opening (m)		Approx. Discharge (cms)
	Gate 1	Gate 2	
235.31	0.30	0.30	25.26
235.01	0.30	0.38	22.89
234.71	0.30	0.45	21.07
234.40	0.30	0.53	20.90
234.10	0.30	0.61	20.76
233.79	0.30	0.69	20.42
233.49	0.30	0.76	19.63
233.18	0.30	0.84	18.27
232.88	0.30	0.91	15.72
232.57	0.30	0.61	11.33
232.27	0.30	0.45	7.93
231.96	0.30	0.30	2.08

The above gate settings can be increased by one level (0.15m) and applied to both gates, if the Spencer Creek limit at Dundas St. (approximately 28.3 cms) is not exceeded. This should only be done at the direction of the Flood Warning Coordinator.

5.3.3 Periods of Low Flow

The system can experience low flows due to lack of rainfall and evaporation of lakes.

The dam operator will need to monitor the dam discharge during low flow periods.

The dam operator may adopt one of the following operations to ensure there will be a minimum discharge of 0.11 cms from the dam to the downstream reach.

1. Open the low flow valve.
2. Allow leakage through the stop logs.
3. Remove one or two stop logs.

6 Equipment, Tools and Safety Procedures

6.1 Equipment and Tools

Operation of the dam must be undertaken in a safe manner and, hence, the equipment required for the operation includes both personal safety equipment and operating equipment.

Aside from Personal Protective Equipment (PPE) such as a hard hat and safety boots, the dam operator's day to day and winter equipment and tools are as described in Appendix C inclusive of item, location, estimated value and supplier.

The dam operators must keep the equipment and tools in good working condition. The equipment and tools should be checked each time after usage and repaired or replaced as required.

6.2 Radial Gate Procedure

The operating controls for the radial gates are located in the Control Building on the north wall overlooking the gates. There are two control panels (one for each gate) located on the south wall in the electrical room. Prior to operating the gates, the levers and switches located in the control panels need to be correctly set. The control panels are shown in the photo below.



Each gate can be operated independently and both of the two gates may be operated at the same time.

The operation of the radial gates has been divided into the following subsections:

- Normal non-operating situation.
- Operating situation.
- Manual operation of the gates by hand drive.
- Manual operation of the gate by self-weights and fan brake.
- Manual operation of the gate by emergency power drive.
- Auxiliary items.

The gates can be operated manually in the case of emergency conditions, e.g. when there is no electrical power for operating the brake or the hoists. There are three alternative methods to operate the gates manually, by hand drive, fan brake or emergency power drive.

6.2.1 Normal Non-operating Situation

In the normal non-operating situation the levers and switches in the control panel are set as follows:

1. Set the power supply switch to "ON" Position.
2. Set the power supply to the hoist motor to "OFF" position.
3. Set the power supply to the gain heaters to "OFF" position.
4. Set the power supply to hoist control to "OFF" position.
5. Set the heater controls to "ON" position.

This provides safety against unauthorized operation.

6.2.2 Operating Situation

In the normal operating situation when the gates are to be moved, the levers and switches in the control panel are to be set as follows:

1. Set the power supply switch to "ON" position.
2. Set the power supply to the hoist motor to "ON" position.
3. Set the power supply to the gain heaters to "OFF" position (In winter set to "ON" position).
4. Set the power supply to hoist control to "ON" position.
5. Set the heater controls to "ON" position.

At the operating controls location (north wall overlooking gates):

1. Press the appropriate pushbutton for each hoist, "RAISE", "STOP" or "LOWER" to raise or lower each radial gate once the control panel switches are set in operating position.
 - a) Raising of gates: Press RAISE button on each gate momentarily. Gates are stopped automatically at FULLY OPEN POSITION, which is also called DOGGED POSITION.

- b) Lowering of gates: Press LOWER button on each gate momentarily. Gates are stopped automatically at FULLY CLOSED POSITION, which is also called SILL BEAM POSITION.
 - c) To stop the gate at an intermediate position, Press STOP once the indicator shows that the gate has reached the required elevation.
2. The position of each gate can be observed through the radial gate position indicators located on each hoist frame. The number indicates the gate opening in feet above the gate sill. In the case of gates fully closed, the number "0" appears opposite to the pointer.

The following table summarizes the positions of the switch or breaker for both operating and non-operating situations.

Switch or Breaker	Gates in Operating Situation	Gates in Non-operating Situation
Power Supply	ON	ON*
Hoist Motor	ON	OFF
Gain Heater	OFF**	OFF
Hoist Control	ON	OFF
Heater Control	ON	ON*

* The power supply must be "ON" at all times to supply power to the host gearbox heaters.

** Switch to "ON" one hour or more before gate operation only in winter when gate may be frozen to the side plates.

6.2.3 Manual Operation Of Gate By Hand Drive

Each hoist can be operated with a hand drive, which is built into the hoists.

The working mechanism of the hand drive consists of chains and a crank for operating it. The hand drive is arranged in a way that a lock mechanism prevents the gate from descending once the chain is connected. During normal operating situation with the electrical motor, the chain for the hand drive is off and is stored in the control building. The crank is also stored in the same location in the control building.

The following procedures to lift and lower the gates should be followed. Refer to Drawing E-06116 (Appendix A) for Mark Numbers.

1. Open the switch cover (Mark No. 25) completely. This automatically disconnects the motor control circuit from the power supply.
2. Connect the roller chain (Mark No. 29) over the sprocket (Mark No. 10) and motor sprocket (Mark No. 34).
3. Manually release the electrical brake on the motor shaft and the hand drive is ready for operation.

Note that the pawl (Mark No. 06) and ratchet wheel (Mark No. 05) have to be engaged all the time for lifting the gates and are not needed for lowering of the gates.

6.2.4 Manual Operation Of Gate By Self-Weights And Fan Brake

When there is no electrical power for operating the brake, the gates can be lowered by their self-weight. The following procedures detail how to lower the gates with self-weight.

1. Move the lever for hand release at the brake and release the brake.
2. Gates will be lowered by gravity and the lowering speed will be controlled by the built-in fan brake.
3. Gates are stopped by touching the sill beam.

The hand release for the electrical brake is located within housing and close to the center of each complete hoist.

6.2.5 Manual Operation Of Gate By Emergency Power Drive

Each hoist can be operated with an emergency power drive unit (Drawing E-06802, Drawings E-06116, Appendix A), when there is no electrical power for operating the hoists.

The working mechanism consists of a groove 6.15" O.D. sheave for V belt permanently attached to the second motor shaft on each of the hoists and a groove 3.75" O.D. sheave for V belt permanently attached to the emergency power drive unit. The levers for handling the clutch and electrical brake are closely located in the same area.

The following procedure details how to lift the gates using the emergency power drive.

1. In order to reach and use the sheave on the motor shaft, the doors in this area of the hoist cover have to be completely opened.
2. Bolt the emergency power drive unit to the mounting pads located on the hoist frame.
3. Release the electrical brake by hand- if the gate is not resting on sill.
4. When the gate is resting on sill beam, put the V belt on and disconnect the gasoline motor by means of the built in clutch.
5. Release the electrical brake by hand and start the gasoline engine.
6. Apply the clutch to lift the gate. The gate will be lifted with nearly the same speed as with the electrical drive.
7. To stop the gate and hold it in any desired position, open the clutch to disconnect the gasoline engine and close the electrical brake by hand at the same time.
8. The gate can be lowered at any time by opening the electrical brake by hand, and the lowering speed will be controlled by the fan brake.

6.2.6 Auxiliary Items

There are some other auxiliary items associated with the gate. These include the side plate, dogging device and gain heater.

1. The side plate is to provide a smooth, straight surface for the side rubber seals.
2. The dogging device is a pin that can be moved outward, with the gate in high position, to allow the gate to rest on the concrete piers
3. The gain heaters are located inside the dam behind the side plates, at the side of each radial gate. They are used only in the winter time when the gates' side rubber seals become frozen to the side plates. Normally, the "Gain heaters" switch is set to the "OFF" position. In winter, set the switch to work an hour or more before attempting to move the gates. The heater indicator light will be on when the "Gain Heaters" switch in the cabinet is set to the "ON" position.

6.3 Overhead Gantry Procedure

A photo of the overhead gantry system at Christie Lake Dam is shown below.



The overhead gantry for the dam consists of the following:

- Galvanized vertical supports.
- Two 2 ton chain hoists.
- Galvanized horizontal track for horizontal movement of hoists.

- Galvanized storage box at one end of the gantry.

Operation of the overhead gantry should follow the following procedure:

- Follow necessary safety procedures regarding safety equipment (hardhat, safety boots, PFD, harness, lanyard).
- 2 workers required, one for each chain hoist.
- Access chain hoists from storage box.
- Slide chain hoists to opposite ends of the steel panel gain.
- Remove the gain cover.
- To install a steel panel, connect hoist chain hooks to steel panel lifting pins, slide steel panel to edge of gain opening, lift steel panel and place over gain opening, lower steel panel evenly into gain until it reaches the sill, release chain hoist hooks from lifting pins using poles, retract chain, replace gain cover.
- To remove a steel panel, connect hoist chain hooks to steel panel lifting pins using poles, lift steel panel evenly from gain until steel panel is clear of deck, lower steel panel onto deck, slide steel panel into storage position, release chain hoist hooks from lifting pins, retract chain, replace gain cover.
- Lop chains over hoists, slide into storage box, lock storage box. Keys for the storage box of the gantry are kept at the HCA office and with the operators.

6.4 Overflow Spillway Procedures

There are two means of removal of flashboards at the crest of the overflow spillway, if required:

1. If sufficient time is available, lift the flashboards manually and store them in a safe place.
2. In case the water in the reservoir is already against the flashboards, pull the steel H-posts out of their holes using chains/cable in the spillway crest to immediately release the flashboards.

6.5 Valve Procedures

A hand wheel can be used to raise or lower the gate valves or the low flow valve.

6.6 Lifting Procedures

At the dam, stop log manipulation is carried out by hand.

The stop log installation/removal procedure mandates:

- A two-person operation.
- All work is to be done from the dam deck of the drop inlet structure (steel grates).
- The use of the life jackets while working on the deck of the drop inlet structure.

For fall protection while working on the drop inlet structure, the operators can attach themselves to the handrails.

6.7 Jacking Procedures

Jacking is not performed at Christie Lake Dam.

6.8 Safety Around the Dam

The dam operators and other personnel must use good judgment at all times in regards to personal safety.

All personnel should be aware of and be familiar with the dangers associated with the dam. Personnel should be aware of the locations of posted signage and the hazards they describe.

Personnel must wear PPE as required (e.g. personal floatation devices, safety boots).

Personnel should use the correct equipment to perform the job at hand.

All equipment should be appropriately stored while not in use so that site hazards are not created.

6.9 Boom

A seasonal safety boom is installed upstream of the Christie Lake Dam during the summer and removed in the fall.

6.10 Ice And Debris Removal

At times, debris can accumulate at the stop log bays and on top of the drop inlet structure steel grates. This debris must be removed to allow unobstructed flow. The operators must carefully observe the conditions and develop a suitable safe plan for the removal of the debris.

Methods of removal at the dam include:

- Using pike poles to direct debris away from the bays towards the shoreline on the upstream side of the structure.
- Using a pole chainsaw to cut trees/branches to allow easier removal.

Ice should be removed from the reservoir as required to ensure a reliable operation of the gates.

No specific ice or debris handling equipment is located at the dam.

7 Inspection and Maintenance

7.1 Inspection

The dam, having a VERY HIGH hazard potential classification, requires an annual visual inspection.

The annual visual inspection is to be recorded on **Form OMSS2** that has been created in the **Christie_OMSS_Forms.xls** workbook. The worksheet named **Form OMSS2** is used to print hardcopy forms, to be used for visual inspection of the dam. The worksheet **OMSS2 - Visual Inspection Records** should be used to input the hard copy information digitally for archiving purposes. **Form OMSS2 - Visual Inspection Records** is shown in Appendix E.

Form OMSS2 lists the items that the dam operator should always inspect. To assist in recording or describing deficiencies, the designations of **poor**, **fair** and **good** have been defined so as to allow operators a means of making consistent observations when completing the forms. In general terms, an item rated **poor** denotes a deficiency that needs to be described along with an appropriate action and schedule. An item rated **fair** should also be described but the action need only be noted as a need to continue to monitor. An item rated **good** would generally require no description or action.

Although a formal detailed visual inspection is required on an annual basis, routine upstream and downstream visual inspections should be undertaken each time the dam operator visits the site to undertake dam operations. For instance:

1. Site Visit

At each site visit to undertake dam operations observe:

- a) Signage
- b) Staff Gauge
- c) Automatic Gauge
- d) Radial Gates
- e) Chain Hoists
- f) Fall Arrest System
- g) Gain Covers
- h) Locks
- i) Safety Boom
- j) Stop Logs
- k) Valves
- l) Drop Inlet Steel Grates
- m) Trespassing
- n) Fisherman
- o) Vandalism
- p) Access Road
- q) Handrails
- r) Walkway

s) Dam (Concrete) Condition

Details of these observations should be documented on **Form OMSS2**.

2. Annually

Undertake a complete detailed visual inspection of all the items listed in **Form OMSS2**, inclusive of video recordings and digital photographs.

Any apparent deterioration or defect rated poor during any of these visual inspections should be recorded. In order to display the initial condition of these defects, and show evidence of progressive deterioration, baseline photographs or video recordings should be taken at greater frequencies and from the same reference location(s). Unusual conditions or observations are to be reported to the HCA immediately. All reports are to be forwarded to the HCA.

Upon receipt of a report of any unusual condition, the HCA Engineer may determine to undertake special inspections by trained officers and/or engineers as deemed necessary. The purpose of these special inspections is to evaluate abnormal conditions causing safety concerns such as crack enlargement or increased seepage.

The HCA will initiate special inspection requirements for a major flood, earthquake and other emergency events.

Details of such visits and recommendations will be documented in separate reports.

3. Dam Safety Review Inspection

The inspection will be carried out as part of a Dam Safety Review, which is required every 10 years (as per the LRIA Best Management Practices, 2011).

7.2 Maintenance

In the **Christie_OMSS_Forms.xls** workbook, two forms have been created for the recording of minor and major maintenance. The worksheet named **Form OMSS3** is used to print hardcopy forms, to be used for manual recording of maintenance at the dam site. The worksheet **OMSS3 - Maintenance Records** should be used to input the hard copy information digitally for archiving purposes.

The recording example of **FORM OMSS3** is provided in Appendix E, in the worksheet **OMSS3 - Maintenance Records**.

At the dam, the following maintenance is required to be performed on an as-required basis:

- Removal of debris
- Grouting of steel support bases
- Steel panel maintenance
- Gain cover maintenance
- Radial gate maintenance

- Chain hoist maintenance
- Valve maintenance
- Drop inlet steel grate repairs
- Stop log replacement
- Concrete repair
- Rust/corrosion repairs
- H-posts and stanchions repairs
- Sign maintenance/replacement
- Handrail maintenance
- Staff gauge cleaning/replacement
- Automatic gauge maintenance
- Vegetation control & slope stabilization
- Gabion baskets repairs
- Access road maintenance

Minor maintenance items should be identified and budgeted for annually. Major maintenance requiring a separate capital request should be prepared with the assistance of MNR and tabled at the Dam Safety Forum.

8 Surveillance and Performance Monitoring

This dam does not have surveillance and performance monitoring equipment installed. Monitoring of the dam performance is undertaken by means of visual inspections. The inspection procedures are described in Section 7.

9 Records

To document dam operation, the operator(s) must record water levels (from staff gauge or automatic water level gauge readings) and gate/valve/stop log settings. These observations should be compiled on **Form OMSS1**.

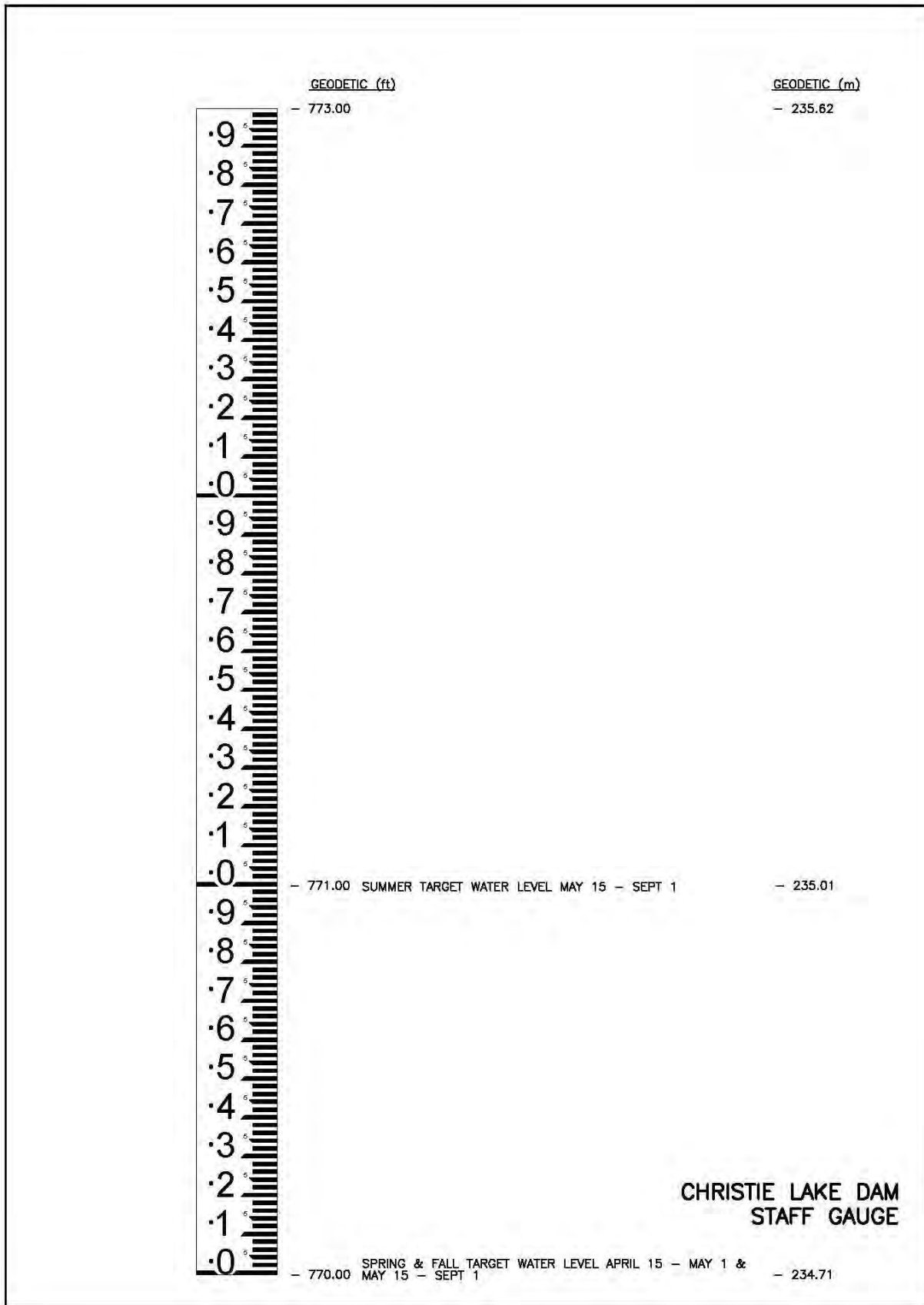
The Christie Lake Dam staff gauge is shown in the photo below. The gauge is correlated to its Canadian Geodetic Datum elevation (in ft). It is mounted on the south wing wall of the concrete control structure on the upstream side.



A water level gauge/staff gauge, resembling the one installed at the dam, is shown in Figures 9.1a and 9.1b.

The staff gauge at the dam is 6.0 ft long. The elevation of the top of the gauge is 776.00 ft GSC. The staff gauge readings can be taken to the nearest 0.01 ft. It is difficult to read the staff gauge due to algae growth.

Figure 9.1a. Staff Gauge



In addition to the staff gauge, there is an automatic water level gauge with data logger located inside the control room (photo shown below).



An EXCEL workbook has been created named ***Christie_OMSS_Forms.xls***. In the workbook, two versions of Form OMSS1 have been created. The worksheet named **Form OMSS1** is used to print hard copy forms, to be used for manual recording purposes. The worksheet **OMSS1 - Operations Records** should be used to input the hard copy records digitally.

Dam inspection undertaken during dam operation must be recorded in the worksheet **OMSS2 - Visual Inspection Records**. Any unusual conditions observed during site operation must be reported to the HCA.

Maintenance must be recorded in the worksheet **OMSS3 – Maintenance Records**.

The following items should be recorded in worksheet **OMSS1 – Operations Records**:

- Column 1 **Date**
- Column 2 **Time**
- Column 3 **U/S Water Level** - Gauge Reading at the Dam
- Column 4 **Flow** - Discharge at the Dam

- Column 5 **Gate Opened/Closed** - Gate opening or closure
- Column 6 **Stop Log Installed/Removed** - # of stop logs in/out of the stop log bay
- Column 7 **Valve Opened/Closed** - Valve opening or closure
- Column 8 **Operations Activities/Comments** - Indicate weather conditions, approximate air temperature, water temperature, snow conditions, wind conditions, any unusual condition(s) and any comments.
- Column 9 **Operator** - Operator's Name

At least one reading of the water level should be recorded. The water level readings must be recorded to two decimals. In addition, the gate and stop log setting and valve opening for the day should be recorded, even if no operation has taken place.

Worksheet **OMSS1 - Operations Records** has been created to maintain a digital record, to provide the information to utilize an adjoining spreadsheet to calculate the flow in each stop log bay and to take the estimated total flow and place that value back into **OMSS1 - Operations Records**. Input all recorded stop log settings and water levels.

An example of the **Form OMSS1** recording is provided in Appendix E.

Electronic versions of the OMSS and OMSS forms are included with this hard copy manual.

10 Public Safety

The HCA Manager of Water Resources Engineering shall ensure that appropriate safety procedures are implemented to warn the public of potential hazards and/or restrict public access. The dam operator must ensure access for unauthorized personnel during operations is prohibited.

Workers shall document and deal immediately with any public safety concerns identified during visits to the water control structure.

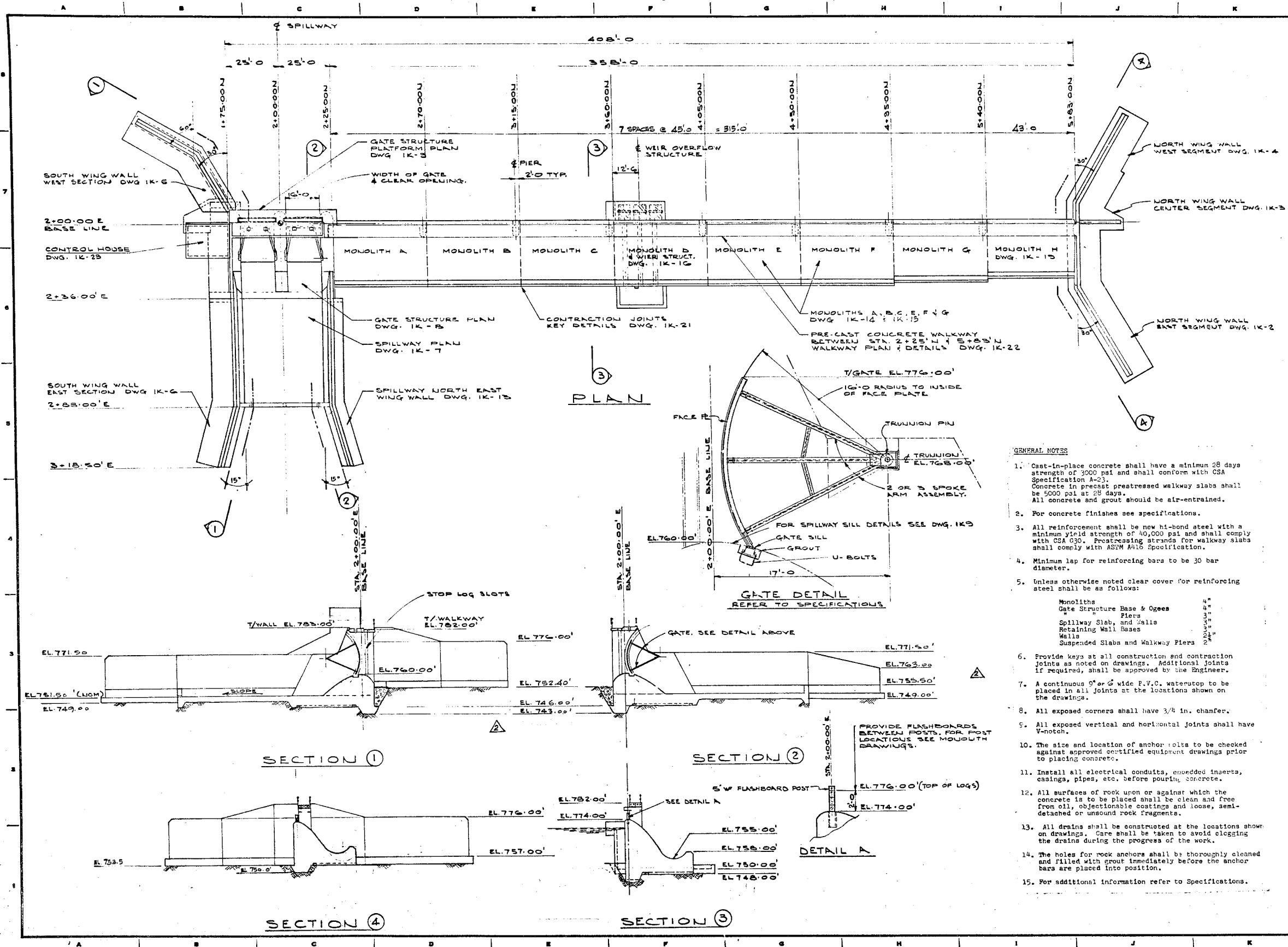
Routine and scheduled inspections shall include a review of potential workplace and public safety hazards and reporting of the same to the HCA Manager of Water Resources Engineering.

Public Safety Measures installed at this dam include:

- Danger Signs
- Handrails
- Safety boom

DRAFT

Appendix A
Record Drawings



REFERENCE DRAWINGS	
DAM SITE TOPOGRAPHY	C-1
WORK AREA ACCESS ROAD	C-2
GENERAL PLAN	C-3
GRADING & SPILLWAY SHT. 1	C-4
" " " " " " SHT. 2	C-5
" " " " " " SHT. 3	C-6
GRADING & DRAINAGE	C-7
NORTH EARTHQUAKE SEGMENT	C-8
SOUTH " " " "	C-9
SPILLWAY CHANNEL	C-10
FENCE & HANDRAIL DETAILS	IJ-2

BY	DATE	REVISIONS	LOC.	NO.
K.C. JUN 4/78		CONCRETE ELEV. ALTERED TO SUIT ROCK ELEVATIONS		
RBM DEC 19/78		CONTROL HOUSE ADDED		

GENERAL NOTES

1. Cast-in-place concrete shall have a minimum 28 days strength of 3000 psi and shall conform with CSA Specification A-23. Concrete in precast prestressed walkway slabs shall be 5000 psi at 28 days. All concrete and grout should be air-entrained.
2. For concrete finishes see specifications.
3. All reinforcement shall be new hi-bond steel with a minimum yield strength of 40,000 psi and shall comply with CSA G30. Prestressing strands for walkway slabs shall comply with ASTM A410 Specification.
4. Minimum lap for reinforcing bars to be 30 bar diameter.
5. Unless otherwise noted clear cover for reinforcing steel shall be as follows:

Monoliths	4"
Gate Structure Base & Ogee	4"
Piers	3"
Spillway Slab, and Walls	3"
Retaining Wall Bases	3"
Walls	2 1/2"
Suspended Slabs and Walkway Piers	2"
6. Provide keys at all construction and contraction joints as noted on drawings. Additional joints if required, shall be approved by the Engineer.
7. A continuous 9" or 6" wide P.V.C. waterstop to be placed in all joints at the locations shown on the drawings.
8. All exposed corners shall have 3/4 in. chamfer.
9. All exposed vertical and horizontal joints shall have V-notch.
10. The size and location of anchor bolts to be checked against approved certified equipment drawings prior to placing concrete.
11. Install all electrical conduits, embedded inserts, casings, pipes, etc. before pouring concrete.
12. All surfaces of rock upon or against which the concrete is to be placed shall be clean and free from oil, objectionable coatings and loose, semi-detached or unsound rock fragments.
13. All drains shall be constructed at the locations shown on drawings. Care shall be taken to avoid clogging the drains during the progress of the work.
14. The holes for rock anchors shall be thoroughly cleaned and filled with grout immediately before the anchor bars are placed into position.
15. For additional information refer to Specifications.



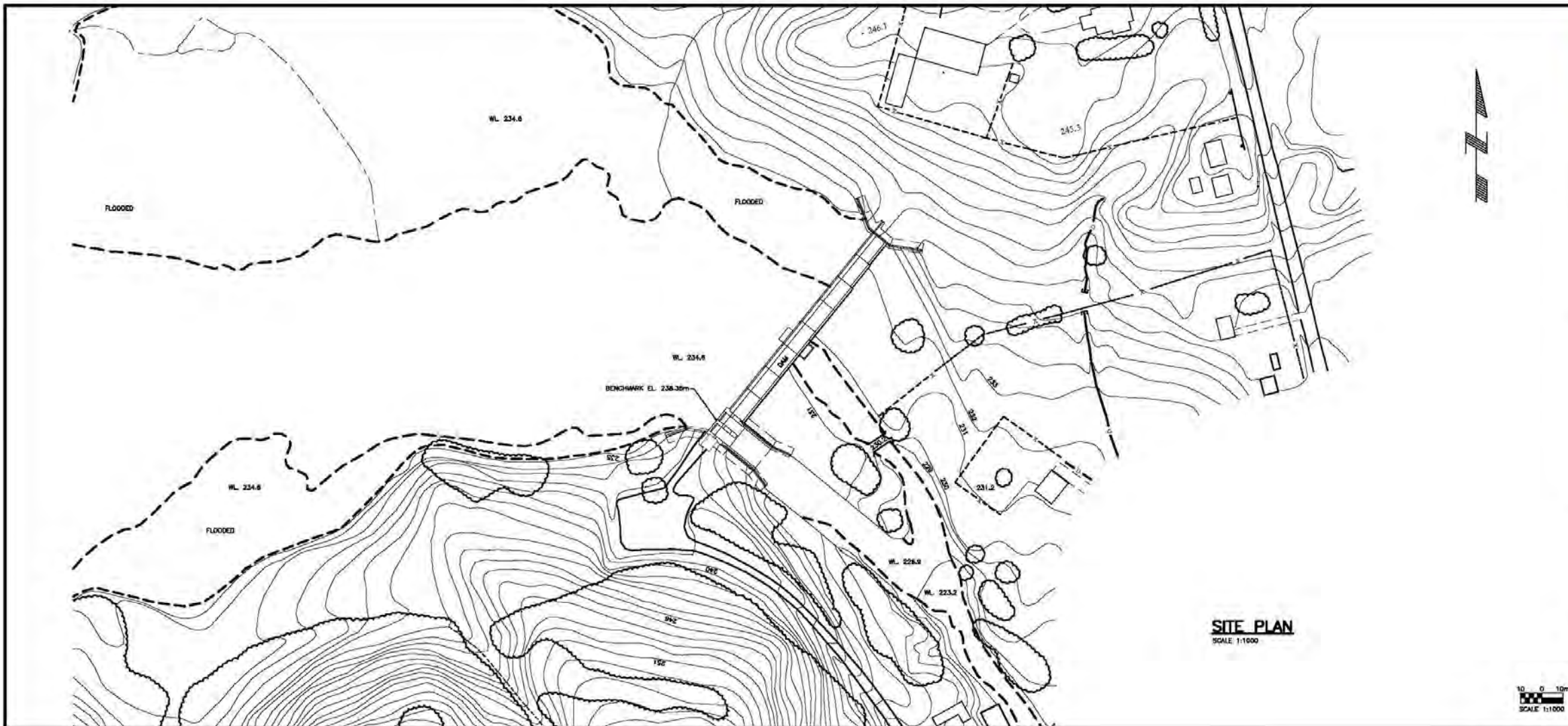
HAMILTON REGION CONSERVATION AUTHORITY
 HAMILTON ONTARIO
CHRISTIE DAM PROJECT

DAM STRUCTURE REFERENCE PLAN AND SECTIONS

FOUNDATION OF CANADA ENGINEERING CORPORATION LIMITED

SCALE 1/4" = 20 FT
 DRAWING NUMBER 3251-1K-1 REV. NO. 2





SITE PLAN
SCALE 1:1000

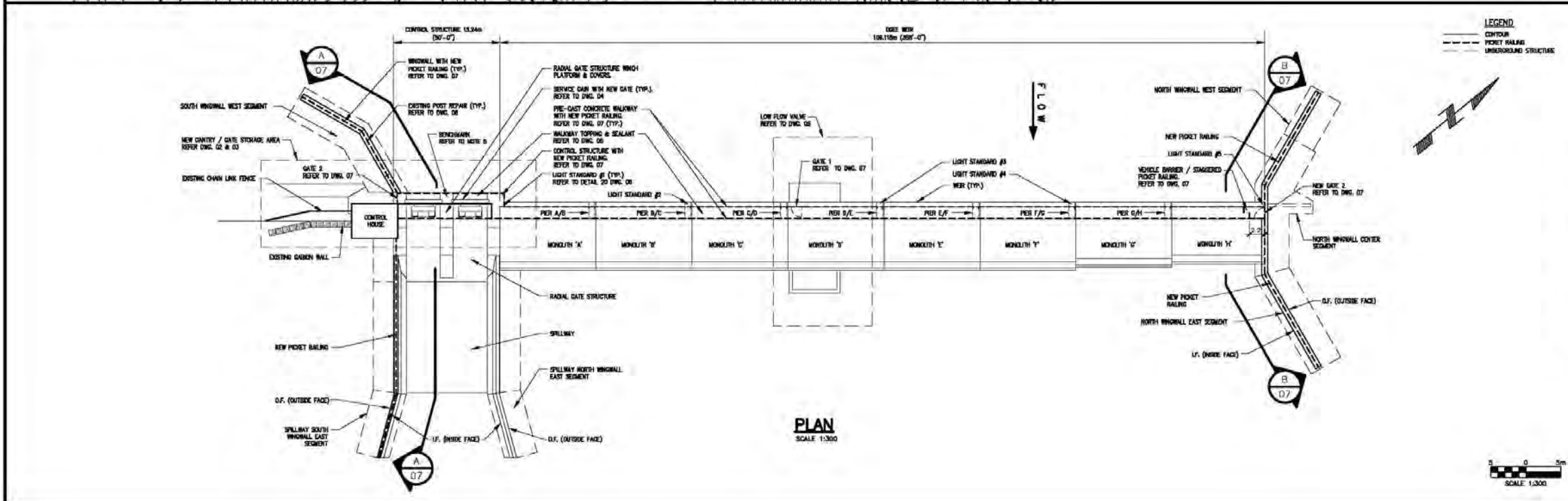


GENERAL SPECIFICATIONS

1. THE DESIGN AND CONSTRUCTION OF THIS PROJECT IS TO CONFORM TO THE REQUIREMENTS OF THE NATIONAL BUILDING CODE OF CANADA - 1995, AND THE ONTARIO BUILDING CODE, 1997, AS AMENDED, AND THE CODES & STANDARDS PROVIDED FOR THE RESPECTIVE ITEMS.
2. PRIOR TO PROCEEDING WITH THE WORK, THE CONTRACTOR SHALL CHECK AND VERIFY ALL DIMENSIONS, ELEVATIONS AND CONDITIONS AT SITE AND REPORT TO THE ENGINEER ANY DISCREPANCIES OR UNSATISFACTORY CONDITIONS WHICH MAY AFFECT THE PROPER EXECUTION OF THE WORK AND THE COMPLETION OF THE PROJECT.
3. MATERIALS SHALL MEET THE FOLLOWING STANDARDS:
DESIGN OF CONCRETE STRUCTURES, CSA-A23.3-94/00.
LIMIT STATES DESIGN FOR STEEL STRUCTURES, CSA-S16.1-01.
COLD FORMED STEEL STRUCTURAL MEMBERS, CAN/CSA-S136-01.
MASONRY DESIGN FOR BUILDINGS, CSA-S304.1-94/01.
CONCRETE MATERIALS AND METHODS OF CONCRETE CONSTRUCTION, CSA-A23.1-00.
METHODS OF TESTING FOR CONCRETE, CSA-A23.2-00.
ENGINEERING DESIGN IN WOOD, CSA-086.1-01.
STRUCTURAL QUALITY STEEL, CAN/CSA-C40.01-04B.
GENERAL REQUIREMENTS FOR ROLLED OR WELDED STRUCTURAL QUALITY STEEL / CAN/CSA-C40.20-04B.
WELDED STEEL CONSTRUCTION (METAL ARC WELDING), CSA-W59-M03.
BULLET STEEL BARS FOR CONCRETE REINFORCEMENT, CAN/CSA-C30.18-M05/00.
WELDED STEEL WIRE FABRIC FOR CONCRETE REINFORCEMENT, CAN/CSA-C30.18-M02/00.
WELDING ELECTRODES, CSA-W48.1-M01 TO CSA-W48.6-01.
STAINLESS STEEL - E316.
4. REFER TO GENERAL CONSTRUCTION SPECIFICATIONS DRAWINGS 10, 11, 12 & 13
5. BENCHMARK AT CONTROL STRUCTURE WALKWAY EL. 234.35M

NO.	REVISION	DATE	APPR.
1	AS BUILT	JULY 2005	
0	ISSUED FOR CONSTRUCTION	MAR 2004	
0	ISSUED FOR TENDER	FEB 2004	
A	ISSUED FOR APPROVAL	JUN 2004	

DESIGNED: _____
CHECKED: _____
DATE: _____



PLAN
SCALE 1:300



Trow Associates Inc.
1595 Clark Boulevard
Brampton, Ontario L6T 4V1
TEL (905) 782-0941 FAX (905) 782-8800

PROJECT
CHRISTIE LAKE DAM
LOCATION
HAMILTON, ONTARIO
TROW PROJECT NO.
0069210A
DRAWING TITLE
SITE & DAM PLAN

SCALE	DATE
AS NOTED	MARCH 2004
DRAWN BY M.S.A.	REV. NO. 0
DESIGNED BY M.H.N.	DRAWING NO. 01
CHECKED BY G.T.	

DRAFT

Appendix B
Reference Photographs

Photo 1: Looking upstream from walkway over ogee spillway (July 2011)



Spencer
Creek

Photo 2: View of upstream face of dam (July 2011)



Ogee Weir

North
Wingwall

Low Flow Inlet

Control
Structure

South
Wingwall

Photo 3: View of upstream face of control structure (April 2011)



Photo 4: Looking downstream from control structure deck (July 2011)



Photo 5: View of downstream face of control structure (July 2011)



Danger Sign

Radial Gate

Photo 6: View of upstream face of ogee weir (April 2011)



Concrete Walkway

Flashboards

Photo 7: Looking downstream from ogee weir walkway at the low flow outlet (July 2011)



Spencer
Creek

Photo 8: View of downstream face of ogee weir (July 2011)



Danger Sign

North
Wingwall

Photo 9: View of south side of dam (July 2011)



Overhead Gantry

Stop Log Gain Covers

Non-slip Surface Coating

Photo 10: View of north side of dam (July 2011)



Danger Sign

Access Restricted to Pedestrians Only

Photo 11: Low flow outlet structure (July 2011)

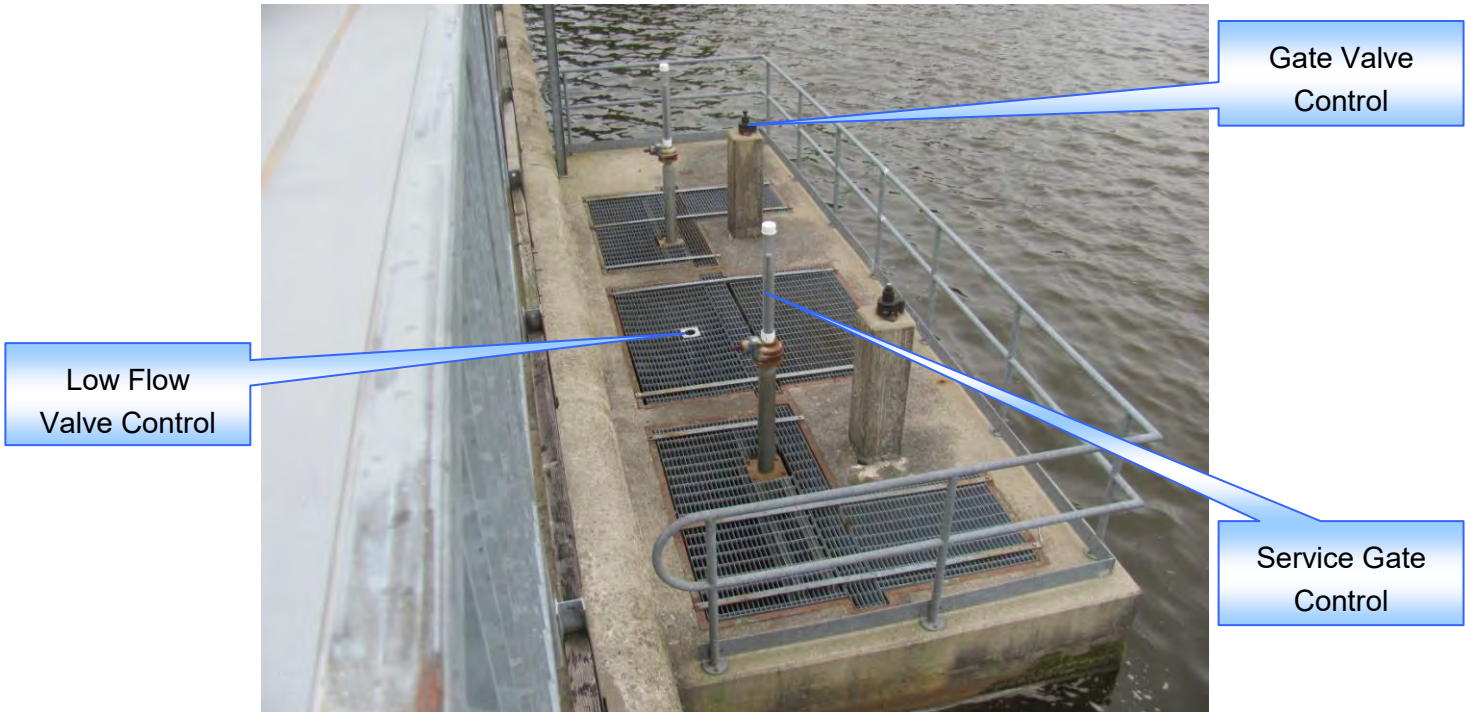


Photo 12: Staff gauge on the south wingwall upstream side (July 2011)

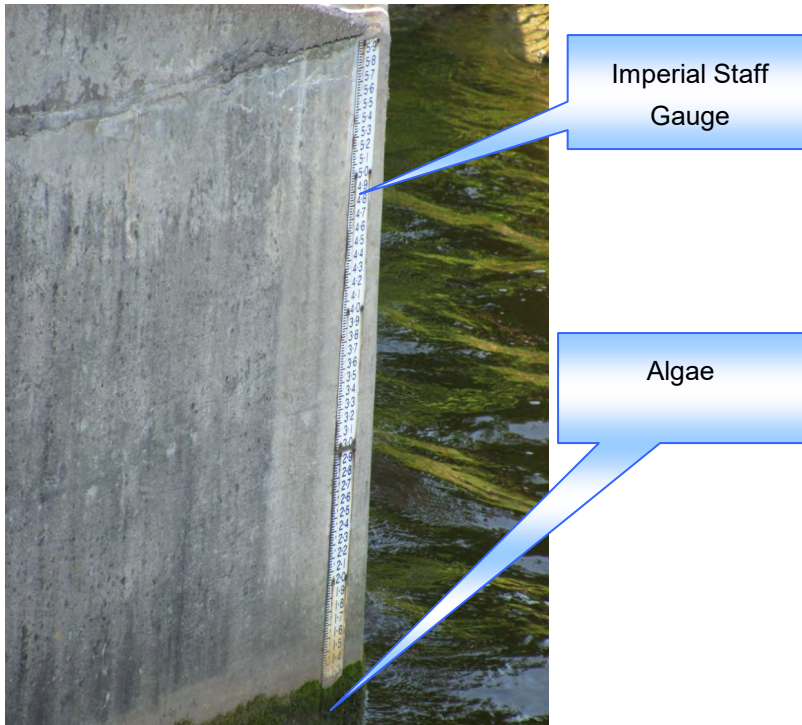


Photo 13: Radial gates control panel (April 2011)



Photo 14: Automatic water level gauge with data logger (April 2011)



Photo 15: Removing the steel panel from the stop log bays (April 2011)



Photo 16: Transporting the steel panels (April 2011)



Photo 17: Steel panels storage area (July 2011)



Appendix C
Equipment and Tools for Dam Operators

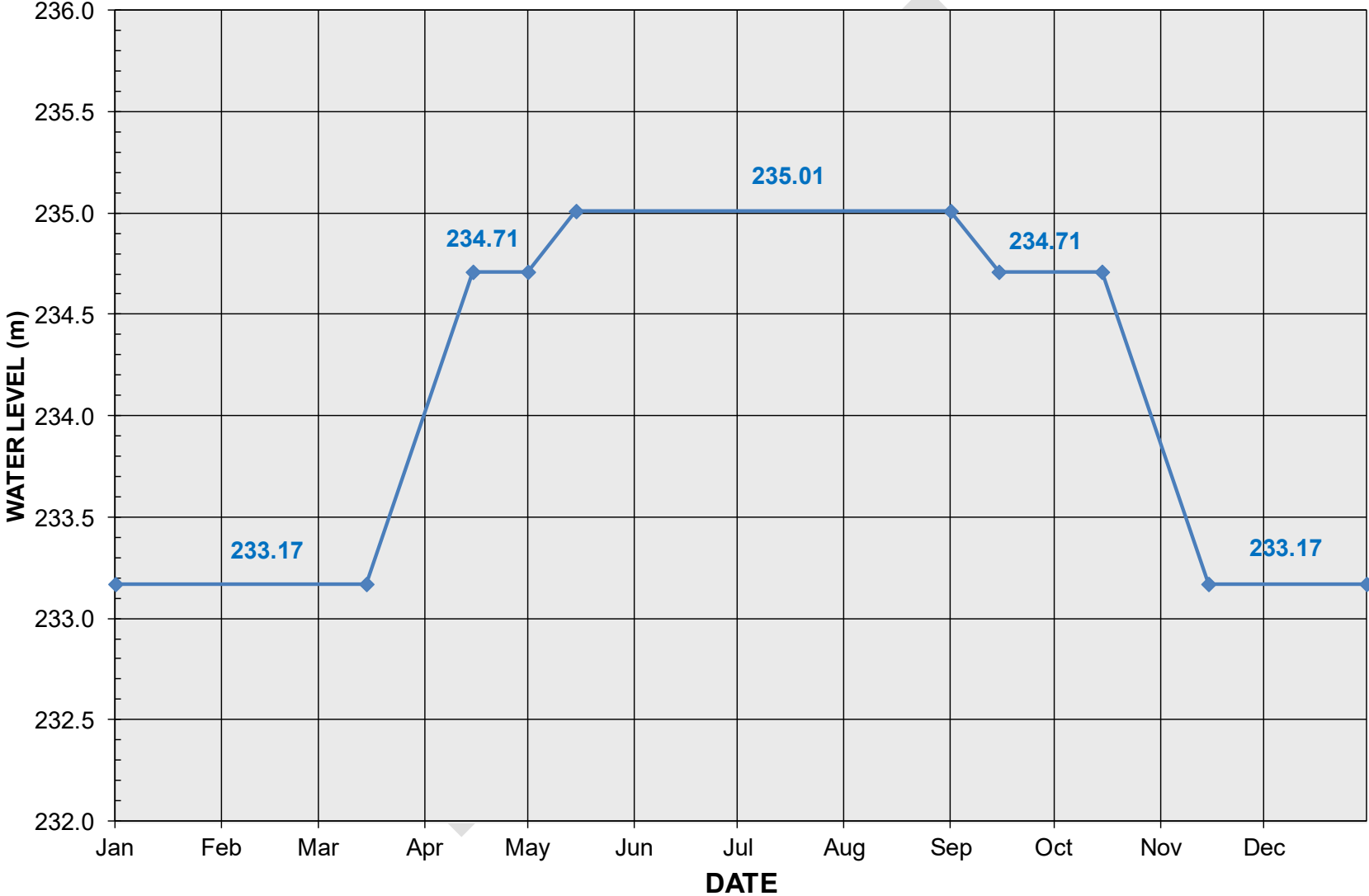
DRAFT

Appendix D

Background Information

- Operating Rule Curve

CHRISTIE LAKE DAM OPERATING RULE CURVE



This page intentionally left blank.

DRAFT

Appendix E

Forms

- Form OMSS 1 - Record of Operation
- Form OMSS 2 - Record of Visual Inspection
- Form OMSS 3 - Record of Maintenance

This page intentionally left blank.

This page intentionally left blank.

Hamilton Conservation Authority

Form OMSS2 – Christie Lake Dam Record of Visual Inspection

Type of Inspection	Formal	Annual	Operational
Inspector Name:			Date:
Control Component	Inspected		Comments
	Defective*	Operational	
Safety			
Signage			
Handrail			
Safety Boom			
Fall Arrest System			
Water Control			
Radial Gates			
Steel Panels			
Chain Hoists			
Gain Covers			
Valves			
Stop Logs			
Steel Grates			
Staff Gauge			
Automatic Gauge			
Dam			
Control Structure			
Overflow Spillway			
Drop Inlet Structure			
Access Road			
Walkway			
Tailrace			
Reservoir			

***Poor:** requires a description along with an appropriate action and schedule.

Fair: requires a description and noted as a need to continue to monitor.

Good: requires no description or action.

Hamilton Conservation Authority

Form OMSS3 – Christie Lake Dam Record of Maintenance

Name:		Date:	
Control Component	Maintenance		Comments
	Defective*	Action	
Safety			
Signage			
Handrail			
Safety Boom			
Fall Arrest System			
Water Control			
Radial Gates			
Steel Panels			
Chain Hoists			
Gain Covers			
Valves			
Stop Logs			
Steel Grates			
Staff Gauge			
Automatic Gauge			
Dam			
Control Structure			
Overflow Spillway			
Drop Inlet Structure			
Access Road			
Walkway			
Tailrace			
Reservoir			

APPENDIX A.2

Valens Lake Dams

Operations, Maintenance, Safety and Surveillance

Preface

This Operation, Maintenance, Surveillance and Safety (OMSS) Manual contains suitable and sufficient information to allow on-site operators to:

- (a) Operate the dam under normal and emergency conditions in a safe manner.
- (b) Maintain the dam in a safe condition.
- (c) Monitor the dam's performance well enough to provide early warning of any distress.

This is not a Dam Design Manual. Detailed engineering aspects such as hydrologic analyses, hydraulic investigations, environmental studies, as-constructed drawings, and formal professional evaluations are documented in other reports and sources.

The OMSS Manual is prepared for Valens Dam, which is located in the Upper Spencer Creek Sub-watershed. It consists of an earth dam and a concrete control structure constructed in 1966. The Manual should be revised as necessary as site experience is acquired.

Valens Dam is an earth embankment with a concrete drop inlet structure controlled by stoplogs and a low-flow intake controlled by a valve. Its primary purpose is to provide low flow augmentation along Spencer Creek during drought periods and flood attenuation during the spring freshet. Additionally, its reservoir is used for recreational activities.

The next dam downstream of the Valens Dam is the Christie Lake Dam, located approximately 30 km downstream of the dam.

This Manual references information provided in the reports entitled "Valens Dam Stability and Safety Study (Acres, Dec. 2004)" and "Emergency Preparedness Plan - Valens Dam (exp 2013)". It is recommended that the operator(s) read and understand the Dam Safety report and Emergency Preparedness Plan (EPP) before operating the dam.

Table of Contents

1	Introduction	1
2	Personnel.....	2
	2.1 Organization Structure	2
	2.2 Duties and Responsibilities	2
	2.3 Emergency Contact Numbers	3
	2.4 Training	3
3	The Dam	4
	3.1 Site Access	4
	3.2 Dam Watershed & Storage	4
	3.3 Spillway and Outlet Works	4
	3.4 Hazard Potential.....	5
	3.5 Inflow Design Flood.....	5
	3.6 Major Repairs and Modifications	5
	3.7 Inspections	5
	3.8 Known Problems and Incidents.....	6
	3.9 Available Drawings.....	6
4	Special Concerns, Known Problems and Constraints.....	9
5	Objectives of Operation.....	10
6	Operational Procedures.....	11
	6.1 General	11
	6.2 Type One Operation (Seasonal)	11
	6.2.1 General Operating Procedure.....	11
	6.2.2 Compliance with PTTW	12
	6.3 Type Two Operation (Flooding and Emergency Conditions).....	13
	6.3.1 Operation in Response to a Rainfall Event.....	14
	6.3.2 Operation in Response to a Spring Snowmelt Runoff Event or Rain-on-Snow Event ..	16
	6.4 Periods of Low Flow	18
7	Daily Operation Equipment, Tools and Safety Procedures	19

7.1	Equipment and Tools	19
7.2	Lifting Procedures	19
7.3	Jacking Procedures.....	19
7.4	Safety Around the Dam.....	19
7.5	Boom.....	20
7.6	Debris Removal.....	20
8	Inspection	21
8.1	Introduction	21
8.2	Dam Safety Review Inspection	21
8.3	Formal Inspections (Annual and Special).....	22
	8.3.1 Annual Inspections	22
	8.3.2 Special Inspections.....	23
8.4	Routine Visual Inspections	24
9	Maintenance	25
10	Records.....	27
11	Public Safety.....	31

List of Figures

Figure 3.1: Valens Dam Location.....	7
Figure 3.2: Spencer Creek Watershed	8
Figure 10.1a. Staff Gauge.....	28
Figure 10.1b. Staff Gauge.....	28

List of Tables

Table 1.1: Location Details.....	1
Table 6.1: Target Operating Water Levels by Season.....	11
Table 6.2: Typical Operations During a Rainfall Event	15
Table 6.3: Typical Operations Following a Rainfall Event	16
Table 6.4: Typical Operations During a Snowmelt or Rain-on-Snow Event	17
Table 6.5: Typical Operations Following a Snowmelt or Rain-on-Snow Event	17
Table 9.1: Suggested Maintenance Activities for Valens Dam	26

Appendices

Appendix A - Record Drawings

Appendix B - Reference Photographs

Appendix C - Equipment and Tools For Dam Operators

Appendix D - Background Information

- Operating Rule Curve
- Stage-Discharge Curves

Appendix E - Forms and Worksheets

- Form OMSS1 – Record Of Operation
- Form OMSS2 – Record Of Maintenance
- Form OMSS3 – Visual Inspection Form
- Sample Total Flow Calculator

1 Introduction

The Valens Dam is located on Spencer Creek, which discharges into Lake Ontario at Hamilton Harbour, near the community of Valens, Ontario within the Valens Conservation Area. The UTM coordinates of the Dam are 4803693 North and 580159 East, UTM Zone 17. The highest elevation of the embankment is 277.3 m.

Table 1.1: Location Details

UTM Zone	UTM East	UTM North	Latitude			Longitude		
			Deg.	Min.	Sec.	Deg.	Min.	Sec.
17	580159	4803693	43° N	22'	58"	80° W	8'	2"

Geographic Township	Lot	Con.	Area Municipality	Regional/County Municipality
Beverly	24	IX	Community of Valens	Hamilton-Wentworth

The dam consists of an earth embankment and a concrete control structure. The concrete structure consists of a drop inlet structure and a low-flow intake. The spillway has a sill elevation of 274.64 m (GSC datum) with four 2.9 m long stoplog bays. Each stoplog bay has 9-76 mm high stoplogs.

This OMSS Manual is a compilation of information used to operate, maintain and monitor the condition of Valens Dam to ensure safe operation. The objectives and procedures are outlined in this Manual and the recording forms are provided in Appendix E. The dam should be operated, maintained and inspected regularly to ensure the safety of the dam, in accordance with the LRIA Technical Guidelines and Best Management Practices (MNR, 2011). This Manual was prepared to assist the operator(s) to follow Hamilton CA and Occupation Health and Safety Act standard procedures.

This Manual does not address all possible circumstances that might provide a threat to the safety or integrity of the dam and related facilities. At least two (2) operators must attend the site. The operator(s) is required to evaluate and report circumstances causing potential concerns for safety, and to implement appropriate corrective actions including operational, maintenance, and remedial measures.

An Emergency Preparedness Plan (EPP), addressing potential emergency situations and outlining appropriate response measures, was prepared and issued under separate cover, "Emergency Preparedness Plan -Valens Dam" (exp 2013).

This Manual should be updated as necessary. Additional information, changes in procedure, or other amendments to operating or maintenance practices affecting dam safety should be incorporated into this Manual.

2 Personnel

2.1 Organization Structure

The Valens Dam is owned by the Hamilton Conservation Authority (HCA). It is operated by HCA staff.

HCA is responsible for the dam. All maintenance, operations, and inspections of the structure are carried out in consultation with HCA.

2.2 Duties and Responsibilities

The dam is a HCA asset, and the HCA Manager of Water Resources Engineering accepts full responsibility for the structure.

The HCA Responsibilities:

- Maintenance
- Operation
- Surveillance
- Inspection
- Training of all personnel involved in dam operations

The Operator's Responsibilities:

- Ensuring that the equipment for dam operation, public safety, communication, etc. are well maintained and in working condition, and supplies and materials needed in an emergency situation are sufficient and placed in an appropriate location or are readily available from local suppliers;
- Ensuring that suitable records of dam-related activities are prepared;
- Ensuring that access to the site is maintained;
- Ensuring the safe operation of the dam;
- Performing routine visual and special inspections of the dam for potential problems (e.g. dam, concrete conditions, inlet drop structure and low flow valve conditions, foundations, seepage and sign of failure, etc.);
- Reporting to the Manager of Water Resources Engineering of any dam deficiencies, vandalism and unusual conditions observed on the dam structure, associated components and equipment whenever they are observed;
- Identifying emergency conditions;
- Notifying the HCA Flood Warning Coordinator or alternate for any emergency condition that is occurring or has occurred. The Flood Warning Coordinator is an HCA staff member who is responsible for flood warning and dam operation during emergency conditions. Presently, the Flood Warning Coordinator duties are fulfilled by the Manager of Water Resources Engineering;
- Taking appropriate actions to mitigate the damages resulting from such emergency conditions, under the direction of the Flood Warning Coordinator or alternate;

- Notifying anyone immediately downstream of the dam that may be in immediate danger when emergency conditions occur;
- Ensuring that there is no public access to the restricted areas;
- To be familiar and trained in EPP and HCA Flood Emergency Manual; and,
- To be familiar and trained in all environmental parameters affiliated with the dam and watercourse (for example, Species At Risk (SAR) in the area).

Additional details regarding the emergency responsibilities for the Dam Operator, HCA Flood Warning Coordinator / Manager of Water Resources Engineering, and other HCA staff involved in dam operation during emergency conditions can be found in the "Emergency Preparedness Plan -Valens Dam" (exp 2013).

2.3 Emergency Contact Numbers

1. Valens Dam		BUS: 905 525-2183
Superintendent	Gord Costie	CEL: 905 973-4373
Lead Hand (Operations)	Ted Doyle	CEL: 905-531-4735
Assistant Superintendent	Joanna Sanche	CEL: 905-531-6795
2. Flood Warning Coordinator / Manager of Water Resources Engineering:	Hazel Breton	BUS: 905-525-2181 Ext. 137 FAX: 905-648-4622 CEL: 905-515-5908 RES: 905-689-7268
2. Water Resources Engineer:	Jonathan Bastien	BUS: 905-525-2181 Ext. 138 FAX: 905-648-4622 CEL: 905-515-3087 RES: 905-921-5650

2.4 Training

Operator training should be undertaken both on a regular basis and by request. New operators should be trained in the following:

- Operational procedures
- Safety requirements
- Minor maintenance of the structure
- Proper use of tools and equipment
- Data recording
- Inspection

HCA is responsible for the arrangement of operator training.

3 The Dam

3.1 Site Access

Valens Dam can be accessed via Regional Road 97. The north side can be accessed through private property from Valens Road and the south side through Valens Conservation Area. The travel time is around 30 minute driving from HCA office (838 Mineral Spring Road, Ancaster, Ontario).

Figure 3.1 shows the location of the dam.

3.2 Dam Watershed & Storage

The Spencer Creek watershed at the dam drains a total area of 10.9 km². The total reservoir surface area within the watershed during summer is 75 ha. The watershed has a maximum reservoir storage capacity of about 204 ha-m (2,040,000 m³) at a maximum design flood level of 276.16 m (figures from Valens Dam Stability and Safety Study, Acres 2004).

Figure 3.2 shows the Spencer Creek watershed.

3.3 Spillway and Outlet Works

Valens Dam consists of an earth embankment and a concrete control structure with a drop inlet structure and low flow intake. The pertinent dam data and elevations are:

Dam:

- Total Length 121.9 m
- Maximum Height 6.3 m

Drop Inlet Structure:

- Sill Elevation 274.64 m GSC
- Perimeter Width 11.6 m (38 ft)
- Stoplog Height 0.152 m (6")
- Number of Logs per Bay 9
 - Size 0.076 m (H) x 0.254 m (W) x 2.9 m (L)
(3" x 10" x 9'-6")

Embankment:

- Crest Elevation 277.30 m GSC

Control Structure:

- Deck Elevation 277.99 m GSC

Low Flow Intake:

- Invert Elevation 270.80 m GSC
- Dimensions 0.91 m x 0.91 m
- Control Valve Diameter 0.36 m

Water Level Gauges Location:

- Metric gauge on the east corner of the drop inlet structure, upstream side

3.4 Hazard Potential

A dam break analysis was previously completed (“Dam Break Analysis – Valens Dam (exp, 2012)). Under the Lakes and Rivers Improvement Act (LRIA) 2011 Technical Bulletin, Classification and Inflow Design Flood Criteria, the Hazard Potential Classification (HPC) of the Valens Dam was determined as VERY HIGH and the inflow design flood (IDF) was selected to be the flood 2/3 between the 1:1000 year flood and the PMF.

The HPC was selected as VERY HIGH due to the potential loss of life between 11 to 100 persons as a result of a dam failure under both sunny day (normal) and inflow design flood conditions.

3.5 Inflow Design Flood

The Dam Break Analysis (exp, 2012) determined the Inflow Design Flood (IDF) for the Valens Dam to be the flood 2/3 between the 1:1000 year flood and the PMF, as per the LRIA Technical Bulletins (2011).

3.6 Major Repairs and Modifications

The Main Dam was constructed in 1966. Repairs/maintenance to the Main Dam since then include the followings:

- Maintenance improvements in 1990
- Repair in 2005, including:
 - The dam impervious core was raised.
 - Downstream toe drain area was repaired
 - Upstream rip-rap was repaired
 - A new traffic surface was installed.
 - Safety signage was upgrades.

3.7 Inspections

The most recent formal inspection of the dams took place in July 2011, by **exp**. Details regarding required inspections are provided in Section 8.

3.8 Known Problems and Incidents

See Section 5.0 Special Concerns, Known Problems and Constraints

3.9 Available Drawings

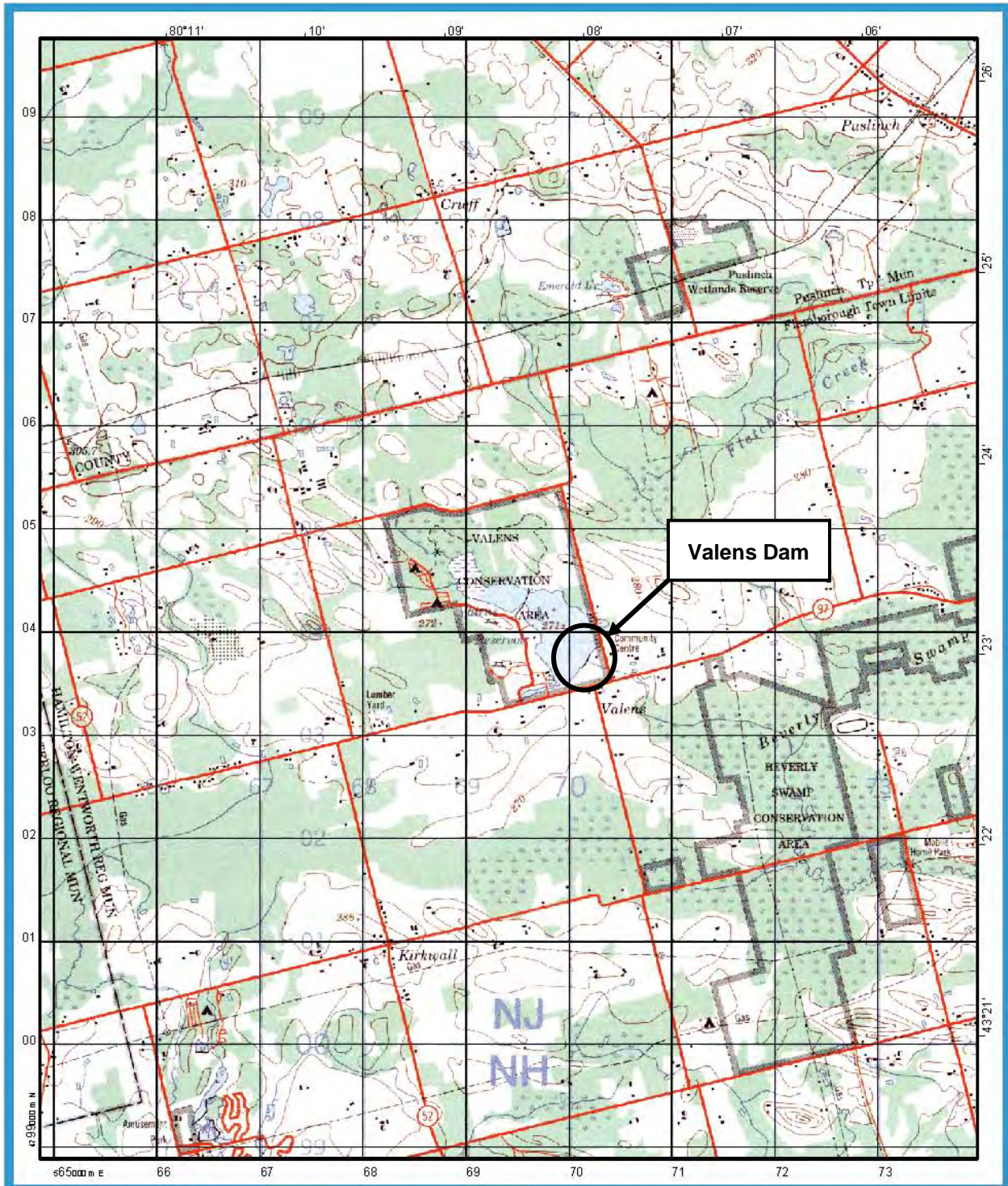
The following drawings are available and provided in Appendix A:

- DWG No. 15816-GT-001, October 2005 Repairs
- DWG No. 15816-GT-002, October 2005 Repairs As Constructed Dam Cross Sections
- DWG No. 694-A-3, General Arrangement of Valens Reservoir and Dam, 1965 As-built conditions

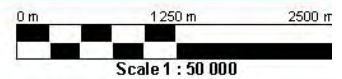
The following information for the dam is also provided in Appendix D:

- Stage-Discharge Curve
- Operational Rule Curve

Figure 3.1: Valens Dam Location

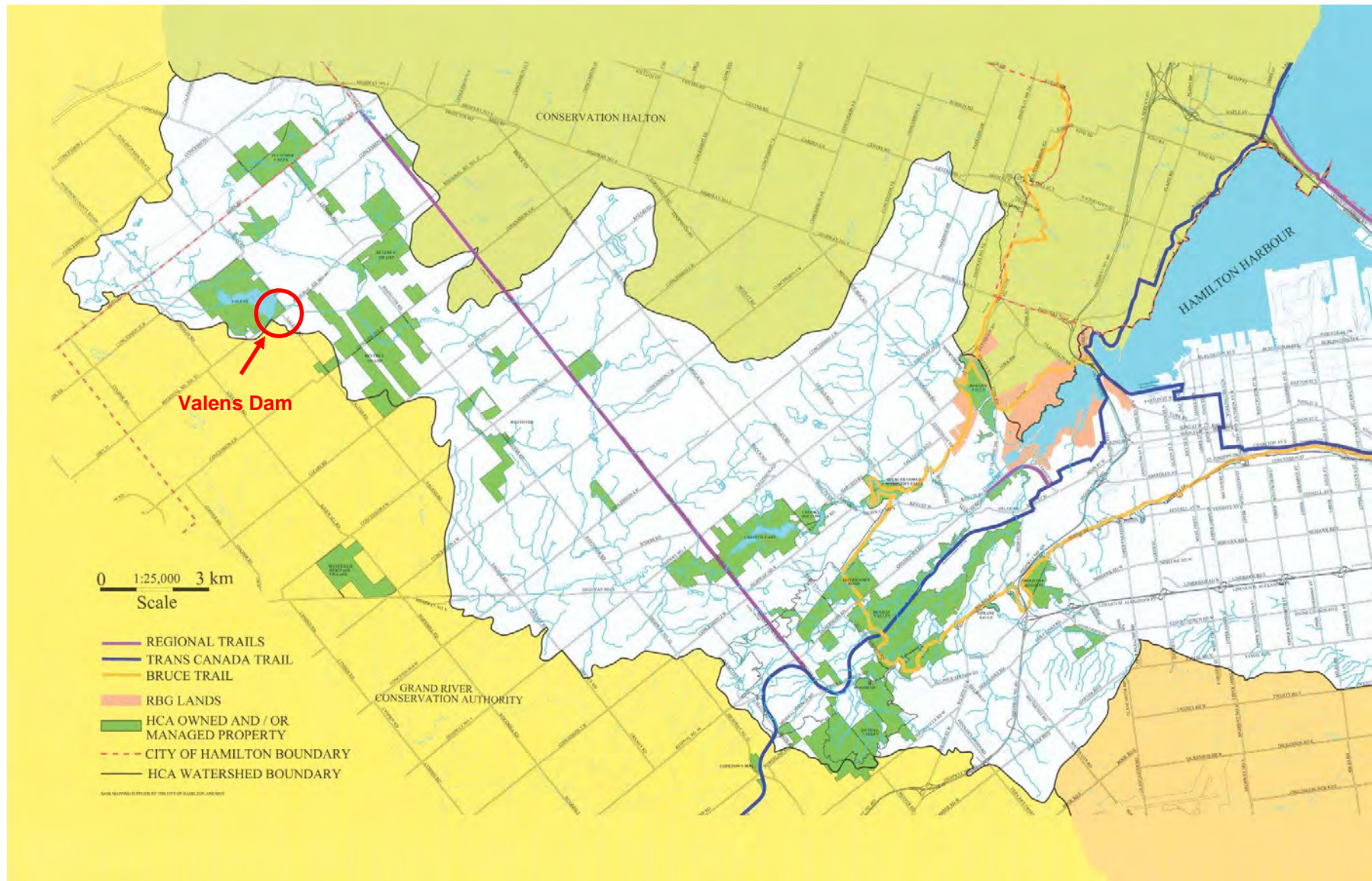


Produced under licences granted by Her Majesty the Queen in right of Canada, represented by the Department of Natural Resources, and by SoftMap Technologies Inc.



This page intentionally left blank.

Figure 3.2: Spencer Creek Watershed



This page intentionally left blank.

4 Special Concerns, Known Problems and Constraints

Lake Use

The dam is located within the boundaries of the Valens Conservation Area.

Public Safety

Public access to the dam site is not restricted. The Valens Reservoir is used for recreational activities.

No incidents of vandalism have been reported at the dam.

5 Objectives of Operation

The primary objectives of the operation of the Valens Dam are to augment summer flow in Spencer Creek during low flow periods and attenuate peak flows during spring runoff. Additional objectives of the dam are to:

- Provide outdoor recreation benefits;
- Minimize water level fluctuations on the reservoir;
- Control discharges from the dam by stoplog and valve operations throughout the year;
- Provide downstream flood control benefits throughout the year by storing water on the reservoir;
- To ensure dam operator safety;
- Ensure the safety of the dam and the potentially affected areas under flood conditions; and,
- Maintain records of the water levels, stoplog operations, discharges and the dam condition.

6 Operational Procedures

6.1 General

Two types of stoplog and valve operations are required for the Valens Dam.

1. Type One Operation (Seasonal)

Maintain the target lake water level on a seasonal basis, as outlined in Section 6.2. In addition, the Valens Dam is subject to a Ministry of Environment (MOE) Permit To Take Water (PTTW). The PTTW stipulates the maximum allowable volume of water that can be taken, in the form of temporary water storage within the reservoir.

2. Type Two Operation (Flooding and Emergency Conditions)

Operate the dam under flooding or emergency conditions when flooding, extreme flood emergency or other unexpected natural disasters occur. These operational procedures are described in Section 6.3.

6.2 Type One Operation (Seasonal)

6.2.1 General Operating Procedure

Under normal conditions, significant changes to the stoplog, and low flow valve settings are required approximately 2 times a year, once during the Spring and once during the Fall. In addition, water levels are routinely adjusted during and after snowmelt and rainfall events by operating the low flow valve. The purpose of the operations is to maintain the reservoir water levels at or near the target water level for the different seasons. A year can be divided into 'Fall', 'Winter', 'Spring' and 'Summer' seasons. Each period has different target water levels and hence the dam needs to be operated accordingly.

The target water levels at the Valens Dam are as follows:

Table 6.1: Target Operating Water Levels by Season

Season	Date	Target Water Level (Gauge Reading) m GSC
Spring	March 15 – Apr 15	274.64
Summer	June 1 – Sept 15	275.25
Fall-Winter	Nov 15 – March 1	273.72

Refer to Section 10, Figures 10.1a and 10.1b. Staff Gauge for key water levels.

6.2.1.1 Fall Operation

Around Sept 15, the winter drawdown of the reservoir begins by gradually removing all stoplogs. The stoplogs are stored in the HCA workshop located within the conservation area.

The water level is decreased below the sill elevation of the drop inlet structure (274.64 m) to the winter target reservoir water level of 273.72 GSC by November 15 by allowing flow through the low flow valve. The valve is operated by turning the stem located on the crest of the control structure.

6.2.1.2 Winter Operation

During the winter months, the low flow valve is kept slightly open (one-eighth of a turn) to prevent freezing. This results in a modest discharge of approximately 0.10 to 0.13 cms.

6.2.1.3 Spring Operation

In the early spring, the reservoir level is carefully regulated to avoid ice cover breakage because of the potential damage that could occur from broken ice accumulation at the dam, docks, and the timber foot bridge that crosses the reservoir.

Generally during March 15 to April 15, reservoir levels typically rise towards the sill elevation of the drop inlet structure (274.64 m), as the dam attenuates peak flows during the spring freshet.

After the spring freshet, typically beginning around April 15, the reservoir is raised to the summer target water level of 275.25 m GSC by June 1 by gradually replacing 8 stoplogs in each of the four bays.

6.2.1.4 Summer Operation

The summer target reservoir water level is maintained throughout the summer. The valve is opened at one-eighth of a turn for downstream low flow augmentation.

6.2.2 Compliance with PTTW

The daily maximum allowable water taking (in the form of temporary storage in the reservoir) is 40,300 m³/day. However, when the daily maximum flows immediately downstream of the reservoir (measured at the Spencer Creek crossing at Safari Road) be expected to exceed 1.5 m³/s, daily water storage volumes greater than 40,000 m³/day are allowed, and are to be managed by HCA as required for flood management purposes. Also, during excessive precipitation, snowmelt or other unpredictable events, HCA is to use best professional judgment to determine appropriate daily water storage volumes.

However, when flows immediately downstream of the reservoir are expected to be less than $1.5 \text{ m}^3/\text{s}$, the maximum allowable water storage is to be limited to 10% of the flow, as measured at the Spencer Creek crossing of Highway 5. This condition is monitored and evaluated on a monthly average basis.

Should average daily flows immediately downstream of the reservoir (measured at the Spencer Creek crossing at Safari Road) be expected to be less than $0.05 \text{ m}^3/\text{s}$, no daily water storage is allowed.

The HCA Water Resource Engineer and HCA Manager of Water Resources Engineering are responsible for monitoring PTTW compliance and providing the HCA dam operator with directions should changes to the low flow valve or stoplogs be required.

6.3 Type Two Operation (Flooding and Emergency Conditions)

This Valens Dam OMSS is to be carried out in conjunction with the Valens Dam Emergency Preparedness Plan (exp 2013) and the HCA Flood Emergency Manual (FEM). The Valens Dam EPP and HCA FEM contain detailed procedures and actions to be followed by various parties in the event of extreme weather with flooding potential. These documents also contain notification procedures and emergency contact numbers for use by the HCA Flood Warning Coordinator.

Flooding resulting from rainfall events may occur at any time of year, but typically occur in late spring, summer or early fall. In addition, flooding may occur from snowmelt or snowmelt plus rainfall events during the spring freshet. The dam operator needs to monitor the weather, reservoir water levels and the dam as required in order to maintain the reservoir water level as constant as possible, and within the operating ranges for the various periods.

The dam operator needs to use his or her own judgment based on historical operations and experience as to when and how many stoplogs would be required to be removed and replaced in each of the stoplog bays and how much the valve would need to be opened or closed.

Stoplog and valve operations during flood conditions should be undertaken by monitoring the reservoir water levels and the weather forecasts closely, in order to determine the correct actions needed. For example, when the reservoir reaches a level whereby stoplogs should be removed or the valve needs to be opened and the forecast indicates that more rain is expected to fall, removing stoplogs and opening the valve would be the correct action. However, if no rainfall is expected, then the stoplogs may not have to be removed or the valve may not have to be opened since the reservoir level may stabilize and start to recede. Note that the magnitude of stoplog manipulation and valve opening should not be based solely upon weather forecasts. Downstream flooding due to operation of the dam must also be considered.

In the event of rapid rising water levels, the chains connected to the steel stanchions that hold the stoplogs can be lifted (e.g. with a front-end loader) to increase the dam discharge capacity.

If the reservoir water level rises to elevation 276.16 m GSC, advise the City of Hamilton to install safety barricades on the Township roads that may be flooded.

6.3.1 Operation in Response to a Rainfall Event

In response to severe rainfall events, the dam is to be operated as required to re-establish the target reservoir water levels for that season as promptly as possible following the rainfall event. Potential downstream flooding due to the operation of the valve and stoplogs during and after the rainfall event are to be accounted for in operational decisions.

Operations during a rainfall event (while reservoir levels are rising), would typically involve the steps detailed as follows in Table 6-2.

Operations following a rainfall event (while reservoir levels are declining), would typically involve the steps detailed as follows in Table 6-3. If at any time the reservoir level begins to rise again before these procedures are completed, follow the low flow valve opening and stoplog removal procedures for operations during a rainfall event at the appropriate elevation.

Additional operational details related to emergency preparedness are provided in the Valens Dam EPP (exp 2013) and HCA FEM.

Table 6.2: Typical Operations During a Rainfall Event

Season	Target Reservoir Water Level (m)	Water Level Conditions During the Rainfall Event	Operation
Late Spring	274.64	Reservoir water level rises above 274.64 m	Open the low flow valve gradually up to full capacity and check the rate of rise.
		Water level continues to rise after low flow valve is fully open	Monitor water level increases and advise the HCA Flood Warning Coordinator or alternate. Under the direction of the HCA Flood Warning Coordinator or alternate, dam operator to complete preventative actions, as well as maintenance and repair actions to stabilize the dam embankment or mitigate other dam condition issues arising due to the high reservoir water levels.
Summer and Early Fall	275.25	Reservoir water level rises above 275.25 m	Open the low flow valve gradually up to full capacity and check the rate of rise.
		Water level continues to rise after low flow valve is fully open	Monitor water level increases and advise the HCA Flood Warning Coordinator or alternate.
		Water level rises to 276.16 m	Under the direction of the HCA Flood Warning Coordinator or alternate, dam operator to remove some or all stoplogs. The HCA Flood Warning Coordinator or alternate will evaluate the potential downstream flooding impacts of removing any stoplogs, as well as whether it is potentially viable and safe to remove only some of the stoplogs. To remove all of the stoplogs quickly, a lifting device (front-end loader, etc) can be used to lift the chains connected to the steel stanchions that hold the stoplogs. Dam operator to advise the HCA Flood Warning Coordinator or alternate once operations are completed.
		Water level continues to rise (above 276.16 m) after all stoplogs are removed and the low flow valve is fully open	Monitor and record water level increases on an hourly basis and advise the HCA Flood Warning Coordinator or alternate. Under the direction of the HCA Flood Warning Coordinator or alternate, dam operator to complete preventative actions, as well as maintenance and repair actions to stabilize the dam embankment or mitigate other dam condition issues arising due to the high reservoir water levels.
Late Fall	273.72	Reservoir water level rises above 273.72 m	Open the low flow valve gradually up to full capacity and check the rate of rise.
		Water level continues to rise after low flow valve is fully open	Monitor water level increases and advise the HCA Flood Warning Coordinator or alternate. Under the direction of the HCA Flood Warning Coordinator or alternate, dam operator to complete preventative actions, as well as maintenance and repair actions to stabilize the dam embankment or mitigate other dam condition issues arising due to the high reservoir water levels.

Table 6.3: Typical Operations Following a Rainfall Event

Season	Target Reservoir Water Level (m)	Water Level Conditions During the Rainfall Event	Operation
Late Spring	274.64	Reservoir water level is above 274.64 m and is declining	Monitor water level decreases. Close the low flow valve gradually before the reservoir level returns to 274.64 m.
Summer and Early Fall (Stoplogs were not removed during event)	275.25	Reservoir water level is above 275.25 m and is declining	Monitor water level decreases. Close the low flow valve gradually before the reservoir level returns to 275.25 m.
Summer and early fall (Stoplogs were partially or fully removed during event)	275.25	Reservoir water level is above 275.25 m and is declining	Monitor water level decreases. Close the low flow valve gradually before the reservoir level returns to 274.64 m or elevation of the top of stoplogs not removed.
		Maintain water level at 274.64 m or elevation of the top of stoplogs not removed.	Adjust low flow valve setting as required to maintain water level, until advised that storm danger has passed by HCA Flood Warning Coordinator or alternate.
		Storm danger has passed	Replace stoplogs and raise water level to 275.25 m by setting low flow valve to 1/8 turn open (minimum for summer flow augmentation).
Late Fall	273.72	Reservoir water level is above 273.72 m and is declining	Monitor water level decreases. Once the water level declines below 274.64 m, close the low flow valve gradually until the reservoir level returns to 273.72 m.

6.3.2 Operation in Response to a Spring Snowmelt Runoff Event or Rain-on-Snow Event

In the spring, the dam needs to be operated to:

1. Respond to snowmelt and snowmelt plus rainfall events.
2. Prepare the dam for the summer settings.

Before the spring annual freshet, dam operations would have been carried out to prepare the dam for the spring runoff. All stoplogs would have been removed from the drop inlet structures bays and the reservoir water level would have been lowered to 273.72 m GSC.

Operations during a snowmelt or rain-on-snow event (while reservoir levels are rising), would typically involve the steps detailed as follows in Table 6-4.

Additional operational details related to emergency preparedness are provided in the Valens Dam EPP (exp 2013) and HCA FEM.

Table 6.4: Typical Operations During a Snowmelt or Rain-on-Snow Event

Season	Target Reservoir Water Level (m)	Water Level Conditions During the Rainfall Event	Operation
Winter	273.72	Reservoir water level rises above 273.72 m	Open the low flow valve gradually up to full capacity and check the rate of rise.
		Water level continues to rise after low flow valve is fully open	Monitor water level increases and advise the HCA Flood Warning Coordinator or alternate. Under the direction of the HCA Flood Warning Coordinator or alternate, dam operator to complete preventative actions, as well as maintenance and repair actions to stabilize the dam embankment or mitigate other dam condition issues arising due to the high reservoir water levels.

Operations following a snowmelt or rain-on-snow event (while reservoir levels are declining), would typically involve the steps detailed as follows in Table 6-5.

Table 6.5: Typical Operations Following a Snowmelt or Rain-on-Snow Event

Season	Target Reservoir Water Level (m)	Water Level Conditions During the Rainfall Event	Operation
Winter	273.72	Reservoir water level is above 273.72 m and is declining	Monitor water level decreases. Once the water level declines below 274.64 m, close the low flow valve gradually until the reservoir level returns to 273.72 m.

6.4 Periods of Low Flow

The system can experience low flows due to lack of rainfall and evaporation of lakes.

The dam operator will need to monitor the dam discharge during low flow periods.

The dam operator may adopt one of the following operations to ensure there will be a minimum discharge from the dam to the downstream river reaches:

- Open the low flow valve;
- Allow leakage through the stoplogs; and,
- Remove one or two stoplog.

Note that under low water conditions, stoplogs may require sealing of joints to reduce leakage between the logs. During very dry summers, the target level is difficult to maintain. Plastic sheeting is placed along the upstream face of the stoplogs to avoid further water loss by leakage.

7 Daily Operation Equipment, Tools and Safety Procedures

7.1 Equipment and Tools

Operation of the dam must be undertaken in a safe manner and, hence, the equipment required for the manipulation of the stoplogs includes both personal safety equipment and operating equipment.

Aside from Personal Protective Equipment (PPE) such as a hard hat and safety boots, the dam operator's day to day and winter equipment and tools are as described in Appendix C inclusive of item, location, purpose, estimated value and supplier.

The dam operators must keep the equipment and tools in good working condition. The equipment and tools should be checked each time after usage and repaired or replaced as required.

7.2 Lifting Procedures

At the dam, stoplog manipulation is carried out by hand. The stoplog installation/removal procedure mandates:

- A two-person operation;
- All work is to be done from the dam deck of the drop inlet structure (steel grates); and,
- The use of the life jackets while working on the deck of the drop inlet structure.

For fall protection while working on the drop inlet structure, the operators can attach themselves to a horizontal bar installed on the upstream face of the intake structure wall. This is normally not required, since the maximum fall height is 0.9 m at the lowest water level.

7.3 Jacking Procedures

Jacking is not performed at Valens Dam.

7.4 Safety Around the Dam

The dam operators and other personnel must use good judgment at all times in regards to personal safety.

All personnel should be aware of and be familiar with the dangers associated with the dam. Personnel should be aware of the locations of posted signage and the hazards they describe.

Personnel must wear PPE as required (e.g. personal floatation devices, safety boots).

Personnel should use the correct equipment to perform the job at hand.

A first-aid kit is located in every HCA vehicle. Flotation life rings are available and stored in the workshop, but not stored directly at the dam.

All equipment should be appropriately stored while not in use so that site hazards are not created.

7.5 Boom

A safety boom is not installed at Valens Dam.

7.6 Debris Removal

At times, debris can accumulate at the stoplog bay and on top of the drop inlet structure steel grates. This debris must be removed to allow unobstructed flow. The operators must carefully observe the conditions and develop a suitable safe plan for the removal of the debris.

Methods of removal at the dam include:

- Using pike poles to direct debris away from the bays towards the shoreline on the upstream side of the structure; and,
- Using a pole chainsaw to cut trees/branches to allow easier removal.

8 Inspection

8.1 Introduction

Regular inspection (surveillance) is an essential component of a complete and effective dam safety program. The purpose of a dam inspection program is to identify potential problems and unsafe conditions so that appropriate maintenance or rehabilitation can be implemented before major problems develop.

Three different levels of inspection are incorporated into the Valens Dam inspection program, as follows:

- Dam Safety Review Inspection
- Formal Inspections (including both annual and special inspections)
- Routine Visual Inspections

8.2 Dam Safety Review Inspection

A Dam Safety Review is a systematic evaluation of the safety of the dam, by means of comprehensive inspection of the structures, assessments of dam performance with a reappraisal of basic features and design assumptions. It generally involves the collection of all available records, field inspection, detailed investigation and possible laboratory testing.

The inspection is required every 10 years (as per the LRIA Best Management Practices, 2011). The Dam Safety Review should be completed by independent engineers qualified by their background and experience in the design, construction and performance evaluation and operation of dams.

Basic components of a Dam Safety Review for Valens Dam are as follows:

- Site Inspection, including dam, reservoir, inlet drop structure, low flow valves and immediate downstream river reach
- Design and construction documents, including design assumptions, design drawings and construction records (where applicable)
- Operation performance, including operating procedures and available documentation
- Maintenance performance, including monitoring and maintenance activities
- Inspection performance, including Formal Inspections and Routine Visual Inspections
- Emergency Preparedness and Response Plan, including assessment of current EPRP and any warning system for emergency
- Compliance with previous reviews

8.3 Formal Inspections (Annual and Special)

8.3.1 Annual Inspections

Formal Inspection is intended to be a thorough inspection. It includes scheduled inspections, which are suggested to be undertaken annually for the Valens Dam, based on in VERY HIGH hazard potential classification. It is suggested that the annual inspection be undertaken either in late spring / early summer after the reservoir water level is at the summer target level, or in late fall / early winter when the reservoir level is at the winter target level. The annual inspection should alternate between Summer and Winter. The annual inspection should be undertaken by appropriate HCA engineering staff, or an experienced consultant, familiar with the dam.

A complete detailed visual inspection, inclusive of video recordings and digital photographs, of all of the components of the dam is to be undertaken:

- Low flow valve
- Inlet drop structure condition (concrete structure, stoplogs, steel grates, steel stanchions, and outlet conduit under the dam)
- Dam Condition (crest, upstream and downstream embankments, reservoir conditions immediately upstream of dam and signs of seepage through dam)
- Signage
- Staff Gauge
- Automatic Gauge instrumentation (by HCA Water Resources Staff as part of monthly site visits to gauge stations)
- Access Road

Visual inspections are to be recorded on **Form OMSS2** that has been created in the **Valens_OMSS2_Form.doc** document. The document is used to print hardcopy forms, to be used for visual inspection of the dam, and to input the hard copy information digitally for archiving purposes. **Form OMSS2 – Valens Dam Record of Visual Inspection** is shown in Appendix E.

Form OMSS2 lists the items that the dam operator should always inspect. To assist in recording or describing deficiencies, the designations of **poor**, **fair** and **satisfactory** have been defined so as to allow operators a means of making consistent observations when completing the forms. In general terms, an item rated **poor** denotes a deficiency, in that the dam component will not (or may not) fulfill the intended purpose. A poor item needs to be described along with an appropriate repair or modification action and a corresponding schedule. An item rated **fair** is expected to fulfill the intended purpose, however minor maintenance works or further study / monitoring. The required maintenance works or further study is to be described. An item rated **satisfactory** is expected to fulfill the intended purpose and requires no minor maintenance works or further study / monitoring actions at this time.

Any apparent deterioration or defect rated poor or fair during an annual visual inspection should be recorded. In order to display the initial condition of these defects, and show

evidence of progressive deterioration, photographs or video recordings should be taken from the same reference location(s).

Poor conditions, unusual conditions, or rapidly progressing deficiencies of any rating are to be reported to HCA engineering staff immediately. All reports are to be forwarded to the HCA engineering staff. Upon receipt of a report of any poor or fair condition, the HCA Engineer may determine to undertake special inspections by trained officers and/or engineers as deemed necessary. The purpose of these special inspections is to evaluate abnormal conditions causing safety concerns such as crack enlargement or increased seepage.

Depending upon the severity of the issue, HCA engineering staff will set the course of action required to address the issue in the short, medium and long term. A more frequent monitoring program, to determine changes over time in an issue, will be developed and managed by HCA engineering staff.

8.3.2 Special Inspections

Formal Inspections also includes special inspections, as required at the discretion of the HCA engineer and dam operators after a significant flood, earthquake, rapid snowmelt, heavy rainfall, or other severe weather. HCA engineering staff will initiate special inspection requirements for a major flood, earthquake and other emergency events.

In addition, special Inspections also include an inspection immediately prior to the expected spring melt period each year. Furthermore, during periods of unusually low reservoir level, the exposed portions of the dams, embankments and reservoir should be inspected.

The inspection items are similar to Routine Visual Inspections. Special Inspections are typically completed by a team of HCA engineers and dam operators familiar with the dam, and often accompanied by consultants familiar with the specific design aspects of the dam.

Details of such special inspections and recommendations will be documented in separate reports (i.e. Special Inspection Report).

Details of these special inspections should be documented on **Form OMSS2**.

8.4 Routine Visual Inspections

Routine Visual Inspection follows a straightforward procedure to assess dam conditions, and involves careful examination of all components of the dam. It is expected that a routine visual inspection will be undertaken by the dam operator each time the dam operator visits the site to undertake dam operations or at a minimum on a monthly basis.

At each inspection, all components of the dam are to be inspected, as per Annual Inspections. Routine Visual Inspections are also to include observable signs of the following:

- Trespass
- Fishing activity from / near the dam
- Vandalism

Details of these routine visual inspections should be documented on **Form OMSS2**. Any apparent deterioration or defect rated poor or fair during any of these visual inspections should be recorded. In order to display the initial condition of these defects, and show evidence of progressive deterioration, photographs or video recordings should be taken from the same reference location(s).

Poor conditions, unusual conditions, or rapidly progressing deficiencies of any rating are to be reported to HCA engineering staff immediately. All reports are to be forwarded to the HCA engineering staff. Upon receipt of a report of any poor or fair condition, the HCA Engineer may determine to undertake special inspections by trained officers and/or engineers as deemed necessary. The purpose of these special inspections is to evaluate abnormal conditions causing safety concerns such as crack enlargement or increased seepage.

Depending upon the severity of the issue, HCA engineering staff will set the course of action required to address the issue in the short, medium and long term. A more frequent monitoring program, to determine changes over time in an issue, will be developed and managed by HCA engineering staff.

9 Maintenance

The required maintenance activities for Valens Dam include the following:

- maintenance on concrete and earth structures;
- vegetation control;
- instrumentation maintenance and repairs; and,
- low flow valve maintenance and repairs.

Table 9-1 provides a list of expected maintenance items, to be performed on an as-required basis.

Valens_OMSS3_Form.doc document has been created for the recording of minor and major maintenance. The document is used to print hardcopy forms, to be used for manual recording of maintenance at the dam site, and to input the hard copy information digitally for archiving purposes. **Form OMSS3 – Valens Dam Record of Maintenance** is shown in Appendix E.

Minor maintenance items should be identified and budgeted for annually. Major maintenance requiring a separate capital request should be prepared with the assistance of MNR, where applicable, and tabled at the Dam Safety Forum.

Table 9.1: Suggested Maintenance Activities for Valens Dam

Item No.	Item	Requirement	Maintenance Activities
1.	Shaft Spillway	Free of obstruction and obvious deterioration	<ol style="list-style-type: none"> 1. Remove floating & trash rack debris 2. Repair concrete deterioration or cracks 3. Repair surface defects as needed 4. Repair or replace any substandard part of the chains and stanchions as needed 5. Replace stoplogs as required 6. Repair/mitigate as required to address observed leakage & seepage 7. Repair defects in steel grates 8. Monitor outlet channel conditions
2.	Low Flow Gate	Safe and satisfactory operation	<ol style="list-style-type: none"> 1. Repair gate as required to maintain operational conditions
3.	Earthfill Dams	Free of seepage and erosion	<ol style="list-style-type: none"> 1. Remove upstream debris 2. Repair deterioration, cracks, settlements, sinkholes or movements in crest on upstream & downstream slopes 3. Repair or replace upstream & downstream slope destabilization and surface erosion 4. Repair or replace seepage and drainage system deficiencies (including toe drain) 5. Fill downstream animal burrows
4.	Riprap	Any displaced or damaged riprap should be replaced as needed	<ol style="list-style-type: none"> 1. Repair and restore riprap immediately after damage 2. Repair or replace deteriorated gabions
5.	Access Road Access road to the dam and on dam crest	To be kept in good condition	<ol style="list-style-type: none"> 1. Repair or replace access road structural, drainage & vegetative deficiencies 2. Close roads during extremely wet weather conditions or when roads are in need of maintenance
6.	Vegetation	All portions of the dam should be kept clear of unwanted vegetative growth	<ol style="list-style-type: none"> 1. Remove any brush cut from the dam and replace with desirable vegetation 2. Mow the grass cover on the dam surface regularly
7.	Safety & Signage		<ol style="list-style-type: none"> 1. Replace any lost, stolen or damaged signs 2. Repair or replace defects in handrails 3. Repair or replace vandalized dam aspects which could potentially affect operational conditions
8.	Gauges		<ol style="list-style-type: none"> 1. Clean staff gauge 2. Monitor accuracy of automatic gauge via manual level checks and make adjustments where required (by Water Resource Engineering staff)

10 Records

To document dam operation, the operator(s) must record water levels (from staff gauge readings) and valve/stoplog settings. These observations should be compiled on **Form OMSS1**.

The Valens Dam staff gauge is shown in the photos below. The gauge is correlated to its Canadian Geodetic Datum elevation. It is mounted on the east wall of the concrete control structure on the upstream side.



A water level gauge/staff gauge, resembling the one installed at the dam, is shown in Figures 10.1a and b.

The staff gauge at the dam is 3.0 metres long. The elevation of the top of the gauge is 278.00 m GSC. The staff gauge readings can be taken to the nearest 0.01 m.

In addition to the staff gauge, there is an automatic water level gauge with data logger is located on the upstream side of the dam at the north end.

Figure 10.1a. Staff Gauge

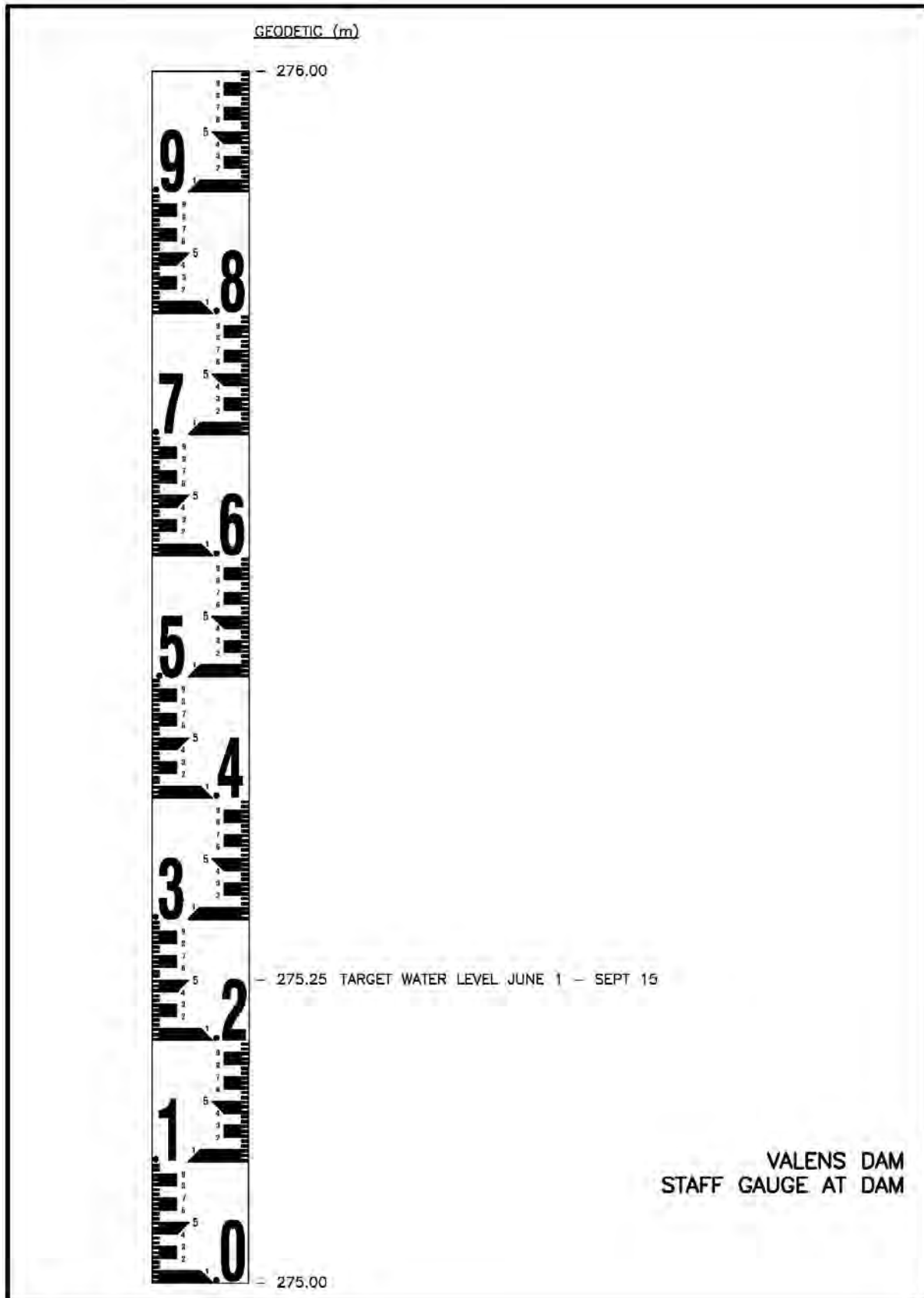
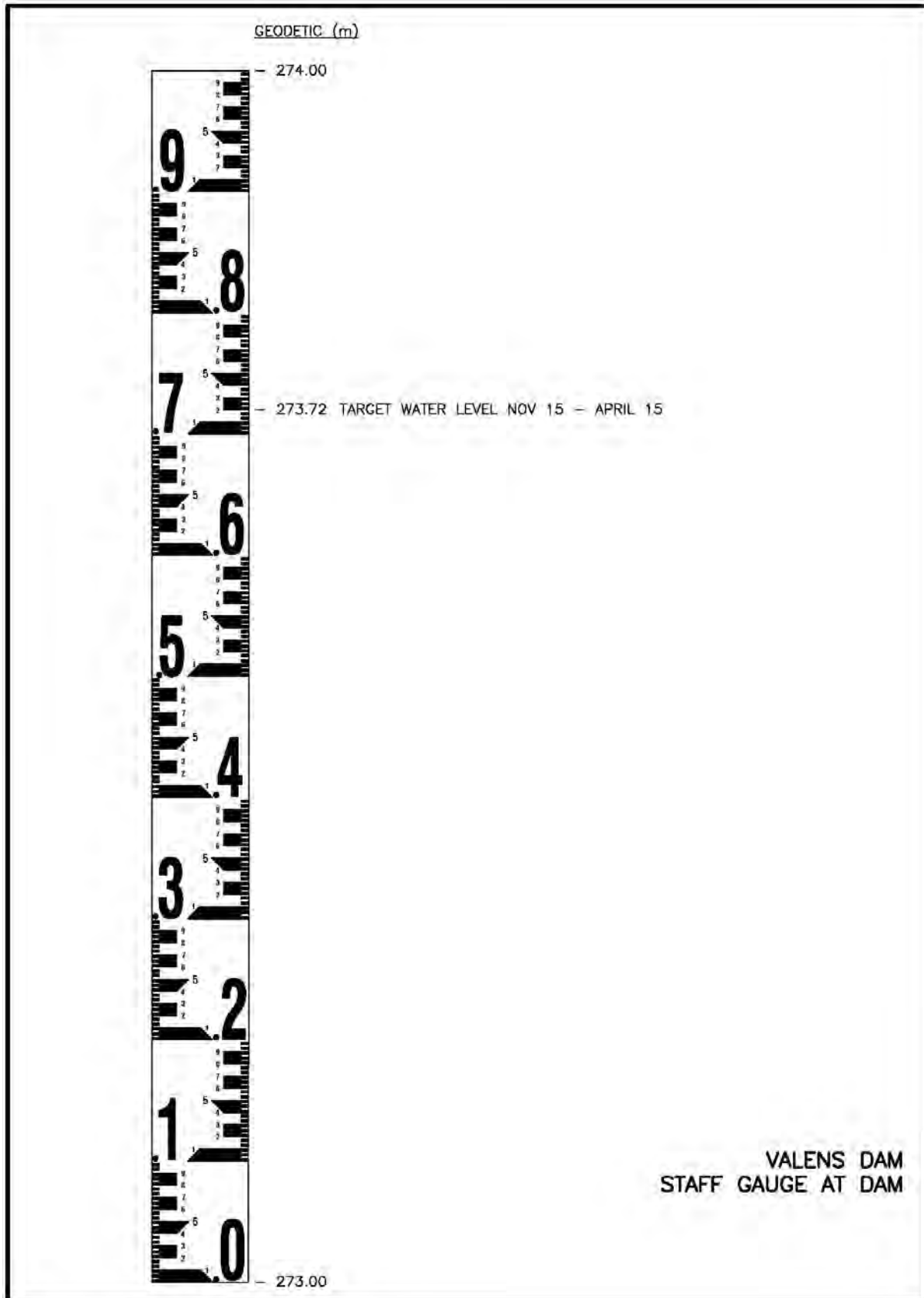


Figure 10.1b. Staff Gauge



A WORD document has been created named **Valens_OMSS1_Form.doc**. The document is used to print hard copy forms, to be used for manual recording purposes, and to input the hard copy records digitally.

Dam inspections undertaken during dam operation must be recorded in the **Form OMSS2 – Valens Dam Record of Visual Inspection**. Any unusual conditions observed during site operation must be reported to the HCA.

The following items should be recorded in **Form OMSS1 – Valens Dam Record of Operation**:

- Column 1 **Date**
- Column 2 **Time**
- Column 3 **U/S Water Level** - Gauge Reading at the Dam
- Column 4 **Flow** - Discharge at the Dam
- Column 5 **Stoplog Installed/Removed** - # of stoplogs in/out of the stoplog bay
- Column 6 **Valve Opened/Closed** - Valve opening or closure
- Column 7 **Operations Activities/Comments** - Indicate weather conditions, approximate air temperature, water temperature, snow conditions, wind conditions, any unusual condition(s) and any comments.
- Column 8 **Operator** - Operator's Name

At least one reading of the water level should be recorded. The water level readings must be recorded to two decimals. In addition, the current stoplog setting and valve opening should be recorded, even if no stoplog manipulations or valve operation have taken place.

Form OMSS1 – Valens Dam Record of Operation has been created to maintain a digital record, to provide the information to utilize the **Total Flow Calculator** spreadsheet to calculate the flow in each stoplog bay and to take the estimated total flow and place that value back into **Form OMSS1**. Input all recorded stoplog settings and water levels.

A copy of the **Form OMSS1** is provided in Appendix E. An example of the results from the **Total Flow Calculator** worksheet is provided in Appendix E.

Electronic versions of the OMSS and OMSS forms are included with this hard copy manual.

11 Public Safety

The HCA Water Resources Manager shall ensure that appropriate safety procedures are implemented to warn the public of potential hazards and/or restrict public access. The dam operator must ensure access for unauthorized personnel during operations is prohibited.

Workers shall document and deal immediately with any public safety concerns identified during visits to the water control structure.

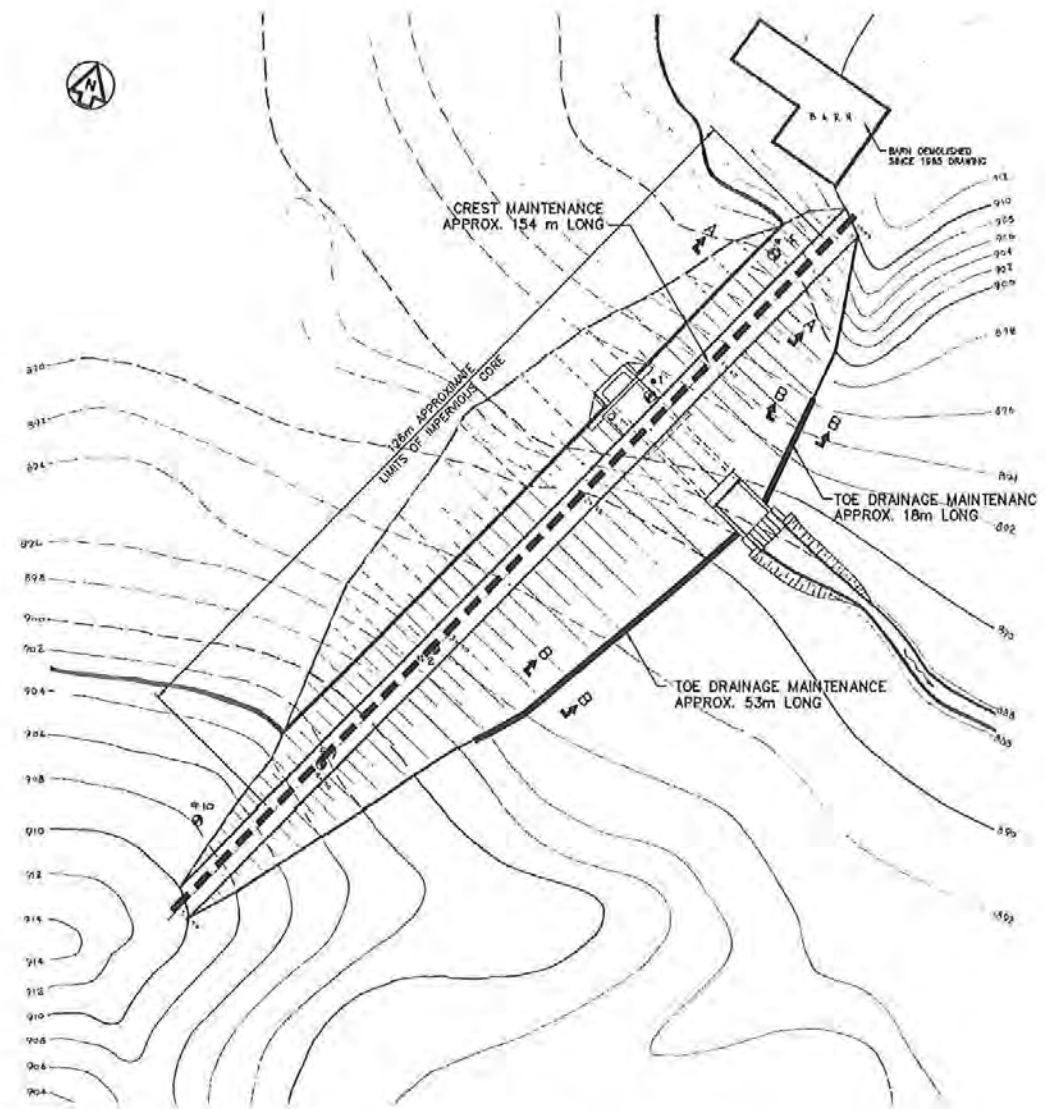
Routine and scheduled inspections shall include a review of potential workplace and public safety hazards and reporting of the same to the HCA Water Resources Manager.

Public Safety Measures installed at this dam include:

- Danger Signs
- Handrails

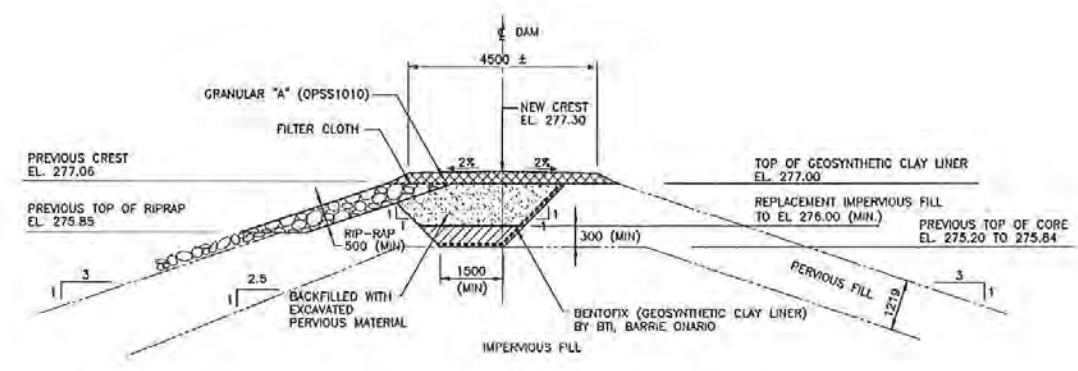
Appendix A
Record Drawings

ALL DIMENSIONS ARE IN MILLIMETRES.
ALL ELEVATIONS ARE IN METRES.



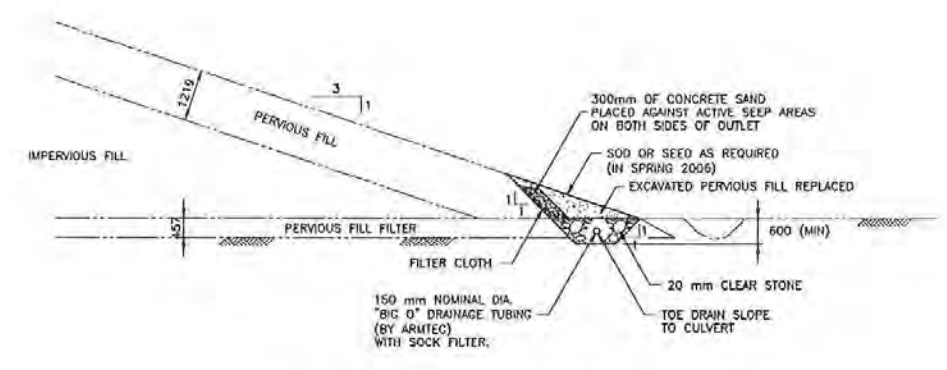
PLAN

DAM - GENERAL ARRANGEMENT
SCALE: 1:500
PLAN AND EXISTING DAM DETAILS FROM AS-BUILT
DWG. NO. 694-A-3, R.K. KILBORN AND ASSOCIATES
NOV. 1965



NOTE:
136.3m OF GEOSYNTHETIC CLAY LINER
WAS INSTALLED ALONG THE CREST

CREST DETAIL SECTION A-A
SCALE: 1:75



TOE DETAIL SECTION B-B
SCALE: 1:75

FOR AS CONSTRUCTED DAM CROSS SECTIONS
SEE DWG 15816-GT-002



DATE	NO.	ISSUE / REVISION	CH.	APP.	APP.
DEC. 05, 2005	1	ISSUED FOR RECORD		BAM	
AUGUST, 2005	2	ISSUED FOR REVIEW		BAM	

ACRES		HAMILTON CONSERVATION AUTHORITY	
		VALENS CONSERVATION AREA, ONTARIO	
		VALENS DAM	
PROJECT ENGINEER		SCALE	
DESIGNED BY R.D. PEGGS		AS SHOWN	
CHECKED BY S. GRAMAM		DRAWING NO.	
APPROVED BY D. PARKES		15816-GT-001	
PROJECT SUPERVISOR		ACRES PROJECT NO.	
		1581600	
PROJECT MANAGER		REVISION	
B.A. MacTAVISH			

Drawn by: R. Kilborn
 Dec. 05, 2005
 Checked by: S. Gramam
 August, 2005
 Approved by: D. Parkes
 Project Supervisor: B.A. MacTavish

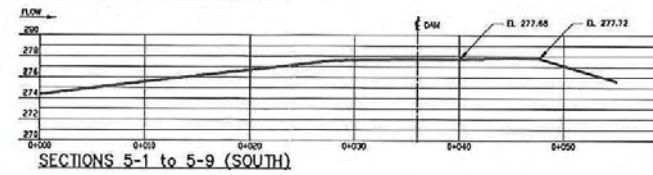
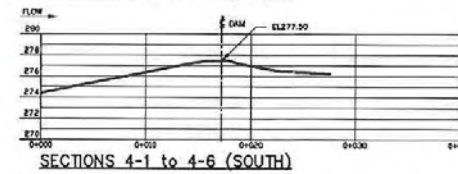
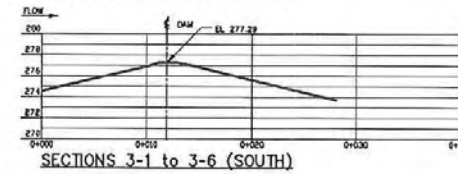
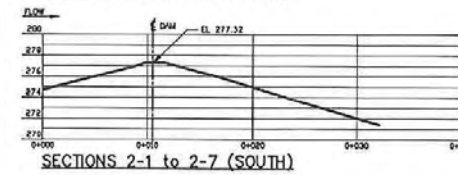
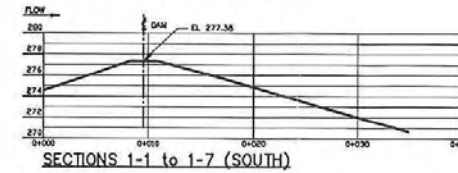
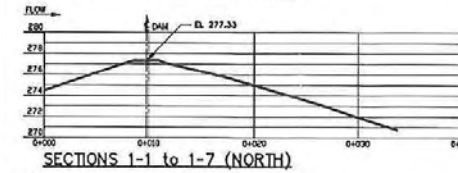
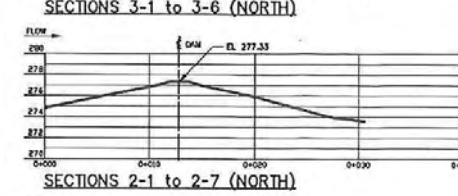
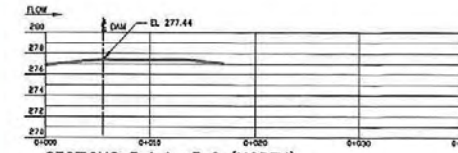
DRAWING No. 15816-GT-001

Plot: 15816-GT-002.dwg
 Date: 2005-11-11
 Drawing Name: 15816-GT-002.dwg

DRAWING No. 15816-GT-002



DAM - AS CONSTRUCTED CROSS SECTION LOCATIONS
SCALE 1:300



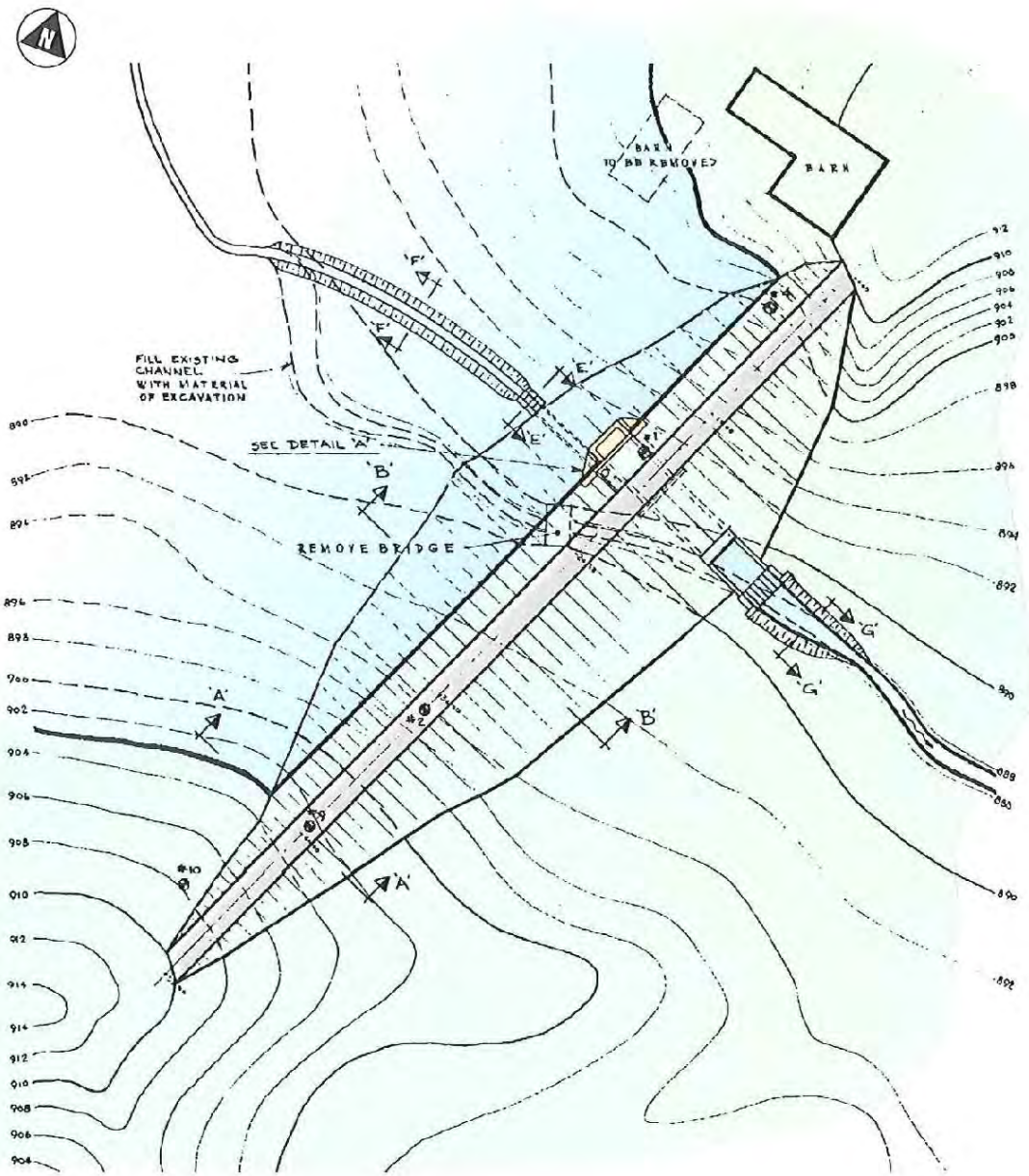
ALL DIMENSIONS ARE IN MILLIMETRES.
ALL ELEVATIONS ARE IN METRES.

NOTES:

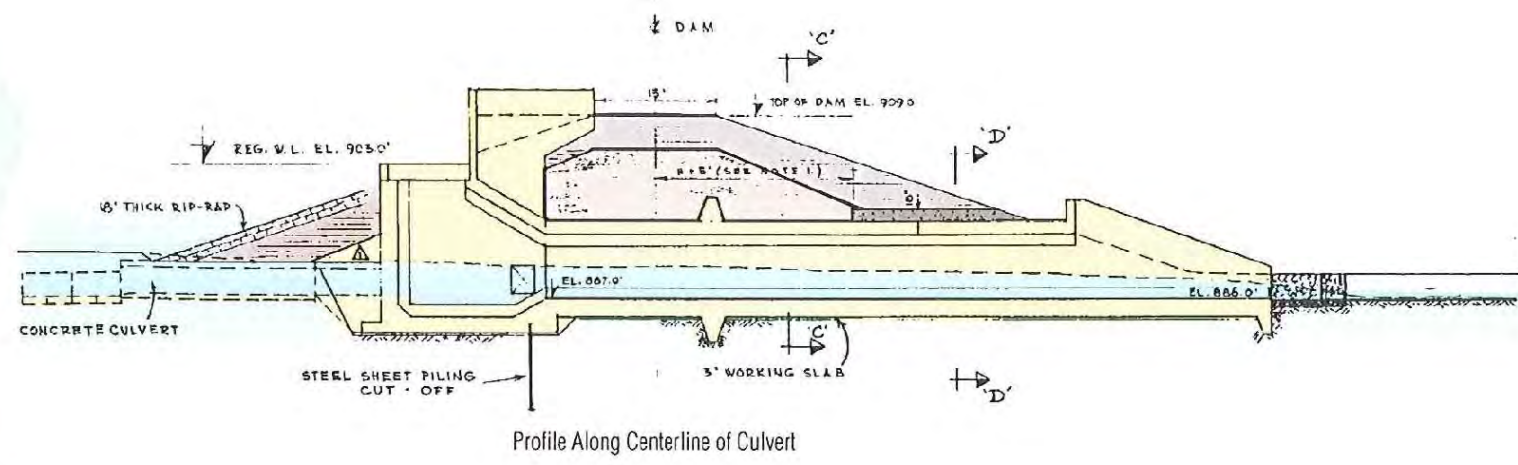
1. BENCH MARK EL. 277.990 LOCATED TOP OF WALL, GATE STRUCTURE UPSTREAM, SOUTH SIDE.
2. SURVEY DATA AND AERIAL IMAGE PROVIDED BY HAMILTON CONSERVATION AUTHORITY AND CITY OF HAMILTON, 2004 AERIAL PHOTOGRAPHY.

ACRES		HAMILTON CONSERVATION AUTHORITY	
VALENS CONSERVATION AREA, ONTARIO		VALENS DAM	
MATCH ACRES			
DESIGN	PREPARED BY	EARTH FILL DAM CREST AND DITCH MAINTENANCE OCTOBER 2005 REPAIRS AS CONSTRUCTED DAM CROSS SECTIONS	
CHECKED	DATE		
DESIGNED	DATE		
PROJECT COORDINATOR	DATE		
PROJECT NUMBER	SCALE	DRAWING NO.	REVISION
B.A. MacTAVISH	AS SHOWN	15816-GT-002	
	ACRES PROJECT NO. 1681600		

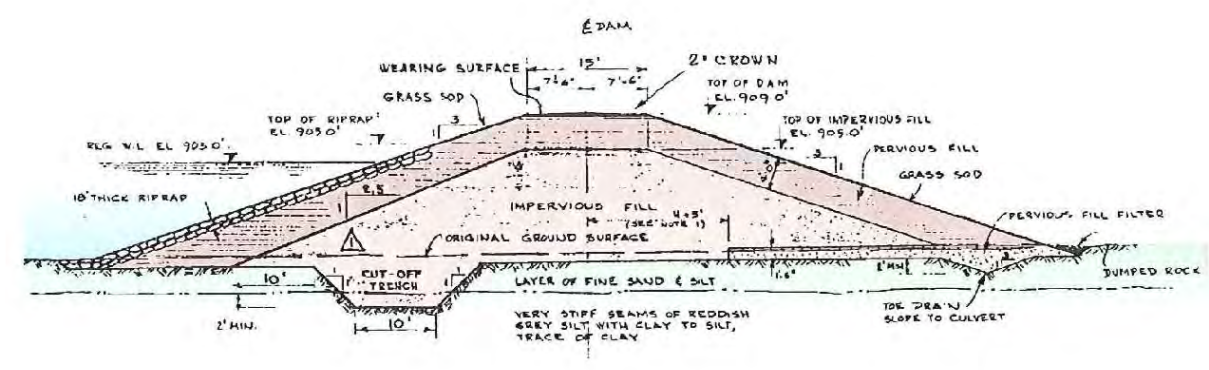
DATE	NO.	ISSUE / REVISION	CH.	APP.	APP.
DEC. 05, 2005	1	ISSUED FOR RECORD		BAM	



Plan



Profile Along Centerline of Culvert



Section B-B

General Arrangement of Valens Reservoir and Dam

This drawing is copied from as-built drawing DWG. No. 694-A-3.
 R.K. Kilborn & Associates, dated November 1965.
 All units are imperial.

This page intentionally left blank.

Appendix B
Reference Photographs

Photo 1: Looking upstream from dam crest (July 2011)



Photo 2: View of upstream face of dam (April 2011)

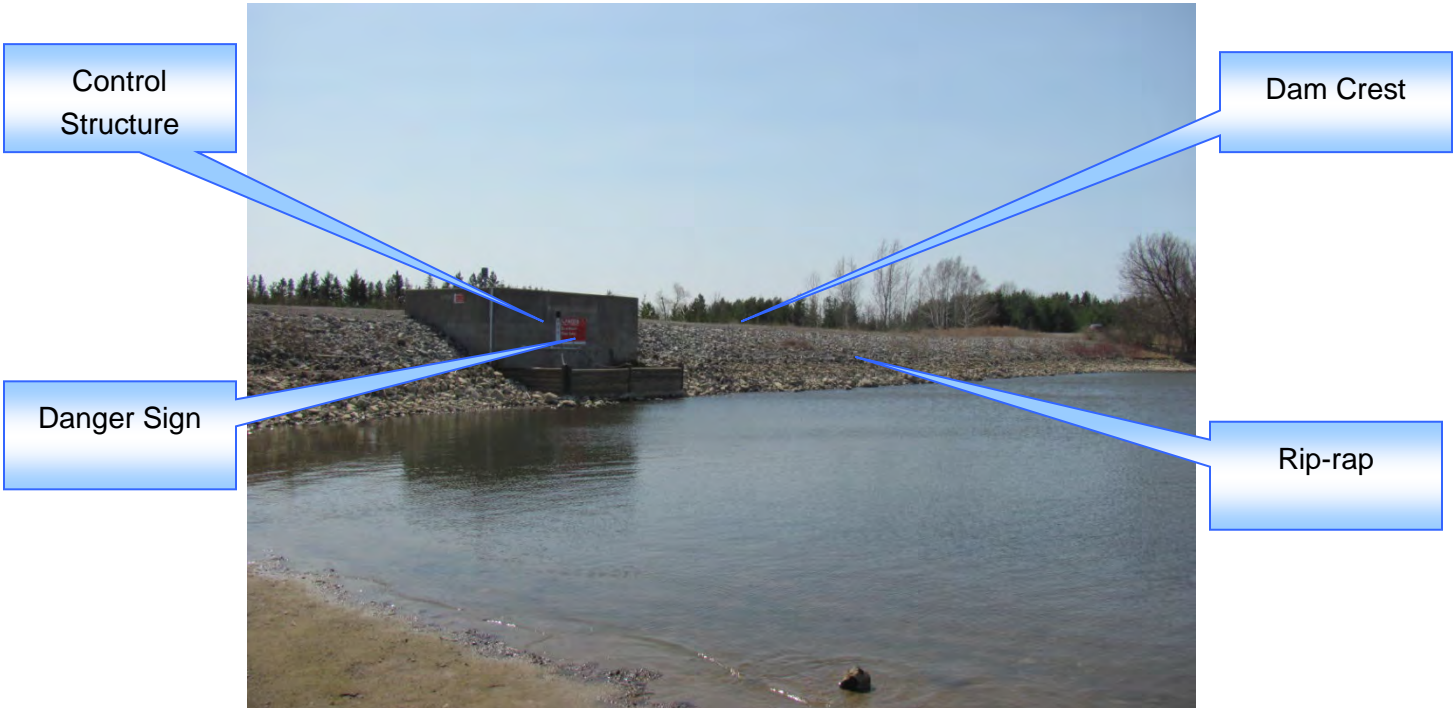


Photo 3: View of upstream face of control structure (April 2011)



Photo 4: Looking downstream from outlet structure (July 2011)



Photo 5: Downstream view of outlet structure (July 2011)

Handrail



Low Flow Outlet

Photo 6: Looking south at dam (July 2011)



Dam Crest/Roadway

Photo 7: Looking north at dam (July 2011)



Dam
Crest/Roadway

Photo 8: Drop inlet structure (July 2011)



Stoplogs

Steel Grates

Photo 9: Downstream toe (July 2011)



Outlet
Structure

Photo 10: Automatic water level gauge with data logger (July 2011)



Appendix C
Equipment and Tools for Dam Operators

This page intentionally left blank.

This page intentionally left blank.

Appendix D

Background Information

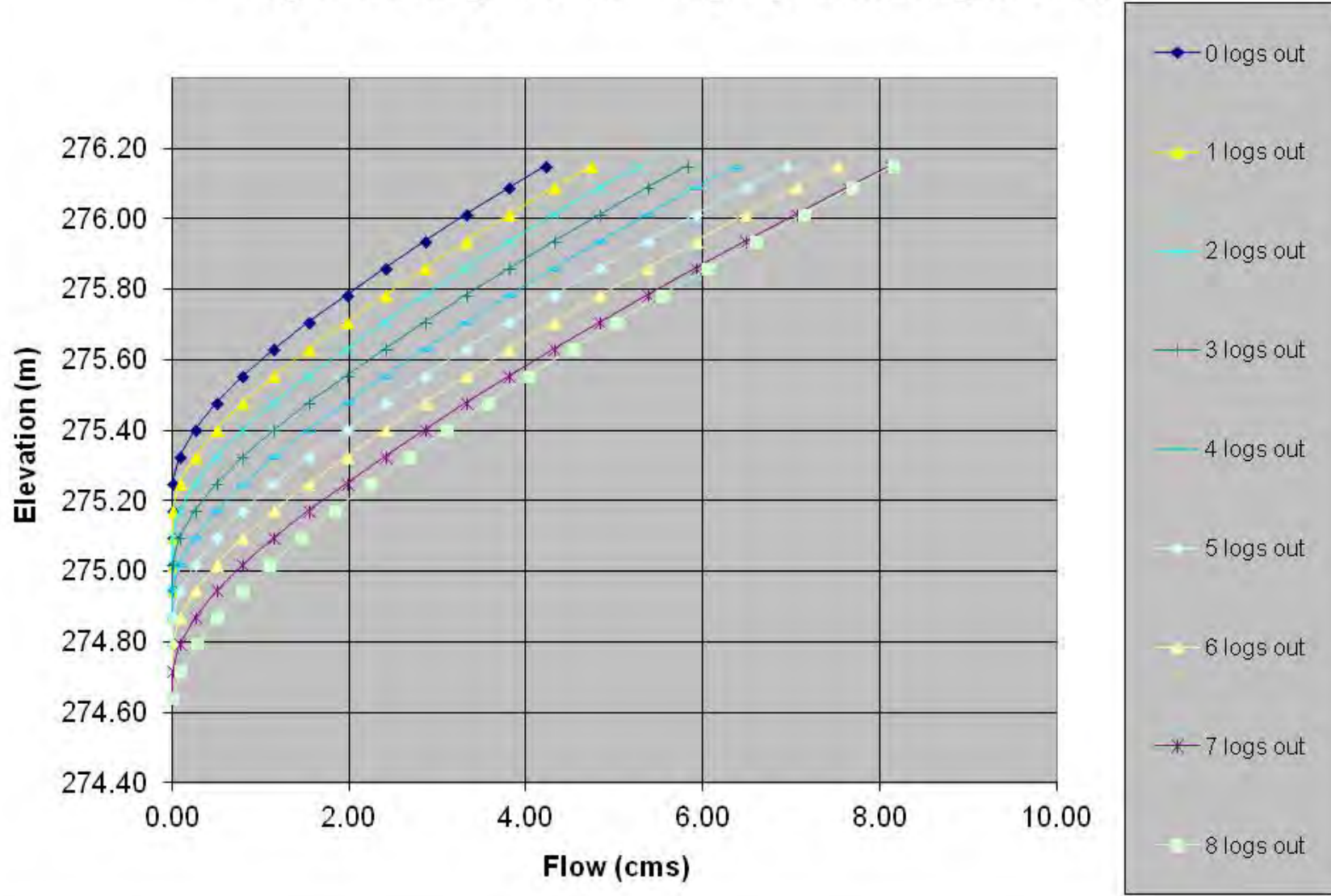
- Operating Rule Curve
- Stage-Discharge Curves

This page intentionally left blank.

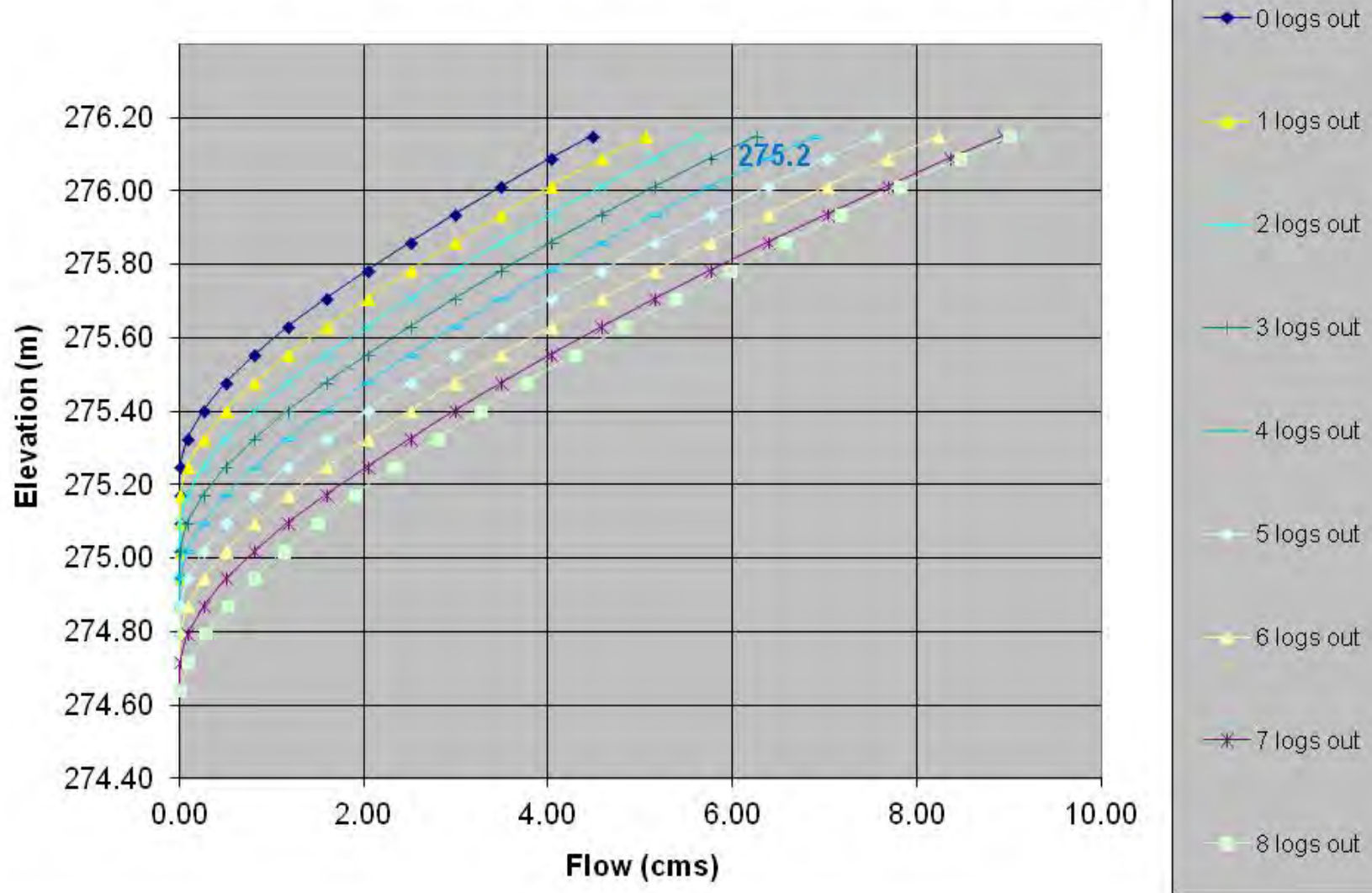
VALENS DAM OPERATING RULE CURVE



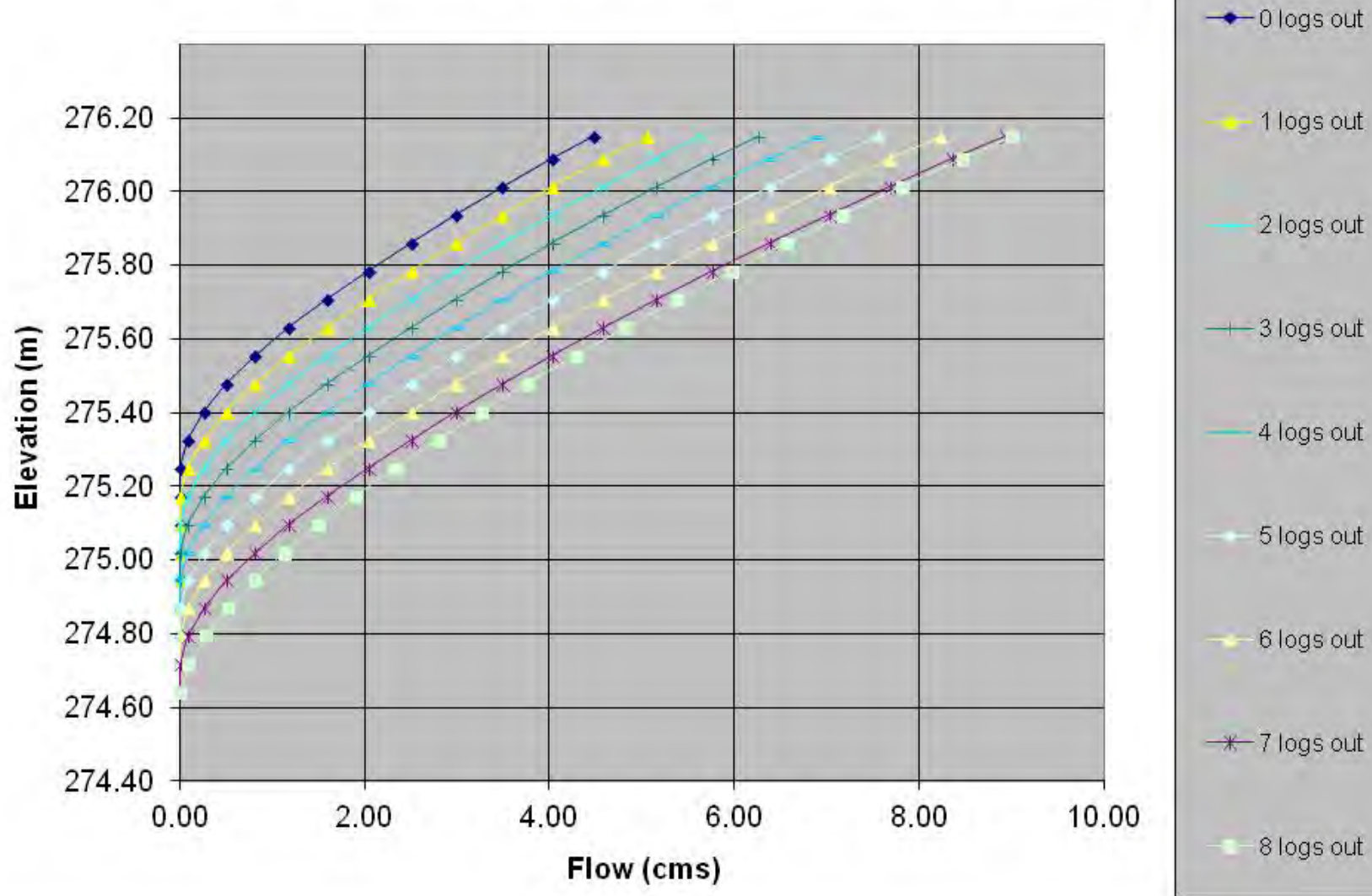
Stage-Discharge Curves - Bay 1 (unsubmerged flow)



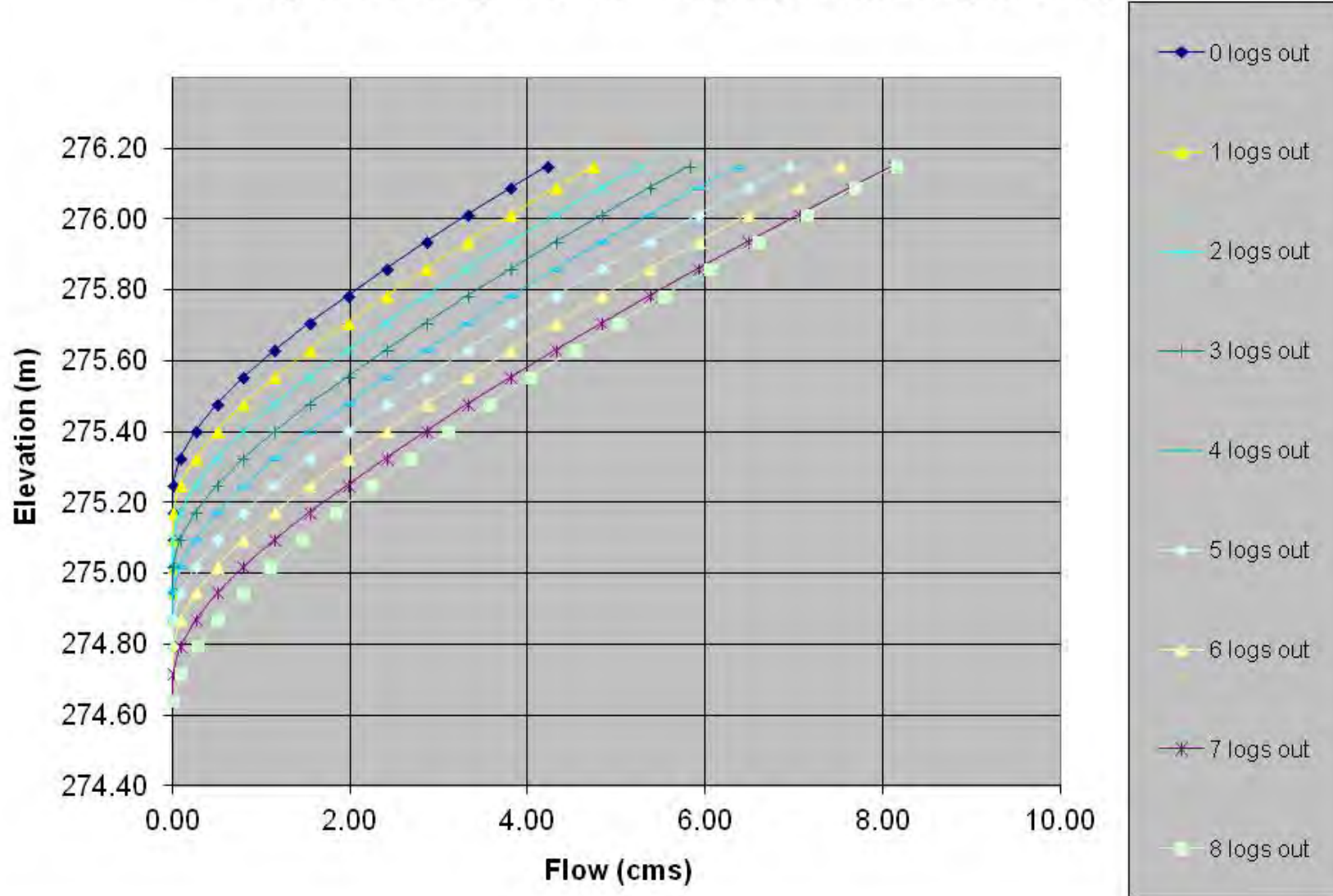
Stage-Discharge Curves - Bay 2 (unsubmerged flow)



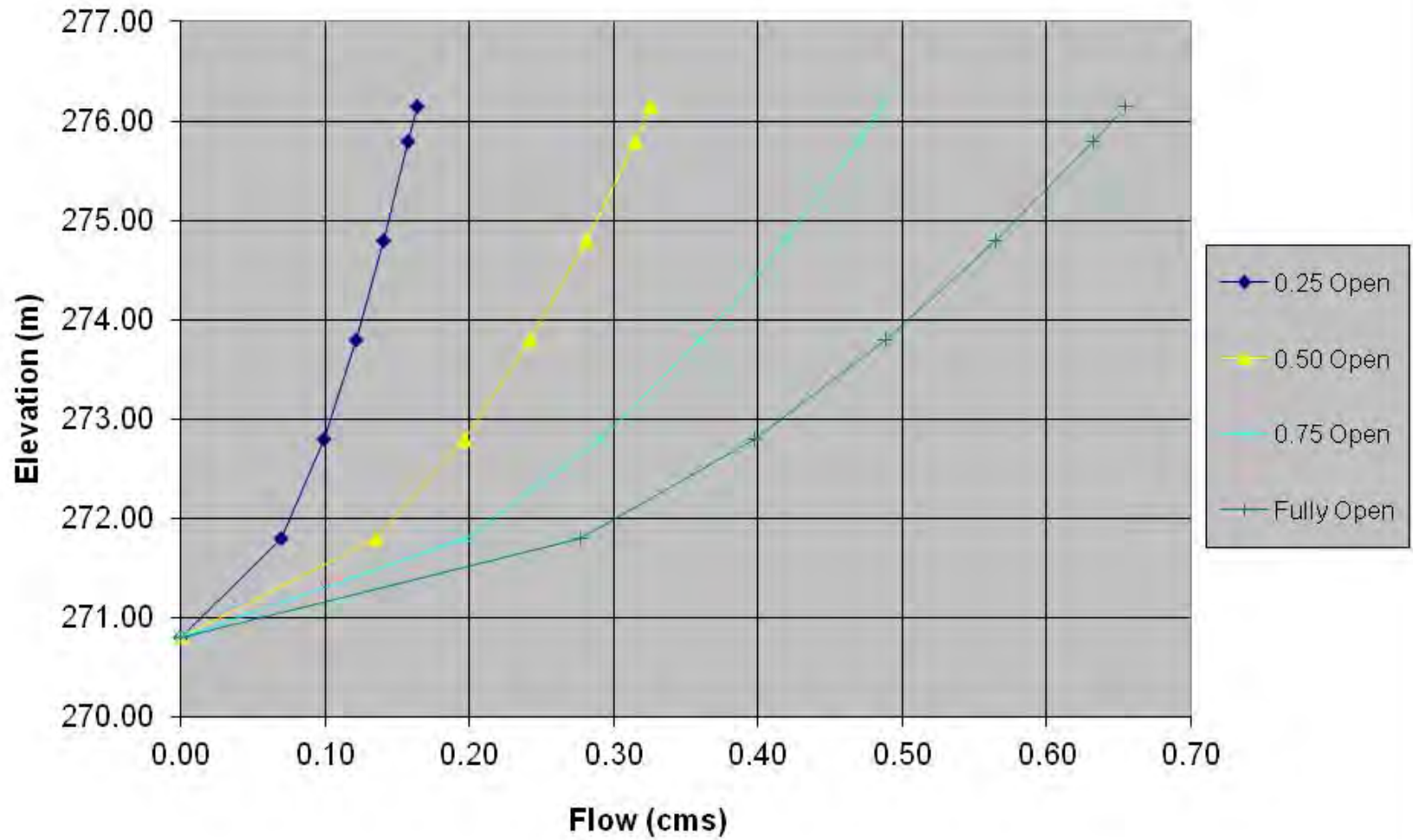
Stage-Discharge Curves - Bay 3 (unsubmerged flow)



Stage-Discharge Curves - Bay 4 (unsubmerged flow)



Stage Discharge Curves - Low Flow Valve



Appendix E

Forms

- Form OMSS 1 - Record of Operation
- Form OMSS 2 - Record of Visual Inspection
- Form OMSS 3 - Record of Maintenance
- Sample Total Flow Calculator Worksheet

Hamilton Conservation Authority

Form OMSS2 – Valens Dam Record of Visual Inspection

All parts of this inspection sheet should be completed. Adverse conditions should be described. Additional information may be put on attached pages.			
FILE NO. _____	INSPECTION DATE: _____		
DAM Name: Valens Dam			
PERSONNEL PRESENT DURING INSPECTION			
Engineer: _____	Others: _____		
Park Staff: _____	Prepared by: _____		
WEATHER			
	<u>Current</u>	<u>Last 3 Days</u>	<u>Last 2 Weeks</u>
Dry	<input type="checkbox"/>	<input type="checkbox"/>	<input type="checkbox"/>
Frost	<input type="checkbox"/>	<input type="checkbox"/>	<input type="checkbox"/>
Rain	<input type="checkbox"/>	<input type="checkbox"/>	<input type="checkbox"/>
Heavy Rain	<input type="checkbox"/>	<input type="checkbox"/>	<input type="checkbox"/>
INSPECTION TYPE			
Routine Inspection <input type="checkbox"/>	Annual Inspection <input type="checkbox"/>	Special Inspection <input type="checkbox"/>	
DAM INFORMATION		Target Op. Water Level: _____	
Reservoir Water Elevation: _____	Freeboard: _____		
Dam Crest Elevation: _____	Current Dam Valve & Stoplog Settings: _____		
OVERALL RATING (Note 1 and see Rating Legend)		Comments:	
Upstream Dam Slope	<input type="checkbox"/>	_____	
Dam Crest	<input type="checkbox"/>	_____	
Downstream Dam Slope	<input type="checkbox"/>	_____	
Inlet Drop Structure	<input type="checkbox"/>	_____	
Access Road	<input type="checkbox"/>	_____	
Gauges	<input type="checkbox"/>	_____	
Safety & Signage	<input type="checkbox"/>	_____	
NOTES			

Note 1: Ratings to be based on inspection findings for each component as per pages 2 - 8

Rating Legend

S = Satisfactory. Will fulfill intended purpose.

F = Fair. Will fulfill intended purpose. Minor maintenance or further review / monitoring required.

P = Poor. May not fulfill intended purpose. Repair or modification required.

N = Not inspected.

Valens Dam Record of Visual Inspection
Upstream Dam Slope

No.	Item	Checked	Condition		
			Rating*	Remarks/Description	Photograph No.
1.	Slope Protection				
2.	Surface Erosion				
3.	Surface Settlements/ Depressions				
4.	Sinkholes				
5.	Cracks/Movements				
6.	Debris				
7.	Vegetation				
8.	Evidence of High Water Table				
9.	Other Unusual Conditions				
10.	General Condition of Reservoir Upstream of Dam (debris, shore erosion, ice conditions, etc.)				
11.	Animal Burrows				
Notes:					

*** Rating Legend**

S = Satisfactory. Will fulfill intended purpose.

F = Fair. Will fulfill intended purpose. Minor maintenance or further review / monitoring required.

P = Poor. May not fulfill intended purpose. Repair or modification required.

N = Not inspected.

Valens Dam Record of Visual Inspection
Dam Crest

No.	Item	Checked	Condition		
			Rating*	Remarks/Description	Photograph No.
1.	Surface Cracks (a) Transverse (b) Longitudinal				
2.	Settlements/Depressions				
3.	Sinkholes				
4.	Lateral Movements				
5.	Erosion				
6.	Vegetation				

Notes:

* Rating Legend

S = Satisfactory. Will fulfill intended purpose.

F = Fair. Will fulfill intended purpose. Minor maintenance or further review / monitoring required.

P = Poor. May not fulfill intended purpose. Repair or modification required.

N = Not inspected.

Valens Dam Record of Visual Inspection
Downstream Dam Slope

No.	Item	Checked	Condition		
			Rating*	Remarks/Description	Photograph No.
1.	Slope Protection				
2.	Surface Erosion				
3.	Surface Settlements/ Depressions				
4.	Sinkholes				
5.	Cracks/Slope Movements				
6.	Seepage/Wet Areas				
7.	Vegetation				
8.	Animal Burrows				
9.	Toe Drain				
10.	Other Unusual Conditions				
Notes:					

* Rating Legend

S = Satisfactory. Will fulfill intended purpose.

F = Fair. Will fulfill intended purpose. Minor maintenance or further review / monitoring required.

P = Poor. May not fulfill intended purpose. Repair or modification required.

N = Not inspected.

Valens Dam Record of Visual Inspection
Inlet Drop Structure

No.	Item	Checked	Condition		
			Rating*	Remarks/Description	Photograph No.
1.	Surface Condition				
2.	General Condition of Concrete				
3.	Stoplogs				
4.	Leakage				
5.	Low Flow Valve & Stem				
6.	Steel Stanchions				
7.	Steel Grates				
8.	Outlet Conduit Under Dam From Inlet Drop Structure				
9.	Outlet Channel Immediately Downstream of Dam				
10.	Foundation & Abutments				
11.	Trash Racks				

Notes:

* Rating Legend

S = Satisfactory. Will fulfill intended purpose.

F = Fair. Will fulfill intended purpose. Minor maintenance or further review / monitoring required.

P = Poor. May not fulfill intended purpose. Repair or modification required.

N = Not inspected.

Valens Dam Record of Visual Inspection
Access Road

No.	Item	Checked	Condition		
			Rating*	Remarks/Description	Photograph No.
1.	Access Road General Condition				
2.	Drainage				
3.	Seepage/Wet Areas				
4.	Vegetation				

Notes:

* Rating Legend

S = Satisfactory. Will fulfill intended purpose.

F = Fair. Will fulfill intended purpose. Minor maintenance or further review / monitoring required.

P = Poor. May not fulfill intended purpose. Repair or modification required.

N = Not inspected.

Valens Dam Record of Visual Inspection

Gauges

No.	Item	Checked	Condition		
			Rating*	Remarks/Description	Photograph No.
1.	Automatic Water Level Gauge				
2.	Staff Gauge				
3.	Precipitation Gauge				

Notes:

* Rating Legend

S = Satisfactory. Will fulfill intended purpose.

F = Fair. Will fulfill intended purpose. Minor maintenance or further review / monitoring required.

P = Poor. May not fulfill intended purpose. Repair or modification required.

N = Not inspected.

Valens Dam Record of Visual Inspection
Safety & Signage

No.	Item	Checked	Condition		
			Rating*	Remarks/Description	Photograph No.
1.	Signs of Trespass				
2.	Signs of Fishing from Dam or in Vicinity of Dam				
3.	Signs of Vandalism				
4.	Signage at Site				
5.	Handrails/Guardrails				

Notes:

* Rating Legend

S = Satisfactory. Will fulfill intended purpose.

F = Fair. Will fulfill intended purpose. Minor maintenance or further review / monitoring required.

P = Poor. May not fulfill intended purpose. Repair or modification required.

N = Not inspected.

Hamilton Conservation Authority

Form OMSS3 – Valens Dam Record of Maintenance

Person Completing Maintenance (Name and Company):		Date:	
Component	Maintenance		Comments
	Deficiency	Action to Address Deficiency	
Safety			
Signage			
Handrail			
Other			
Water Control			
Valve			
Stoplogs			
Steel Grates			
Steel Stanchions and Chains			
Staff Gauge			
Automatic Gauge			
Outlet Channel			
Other			
Dam			
Concrete Structure			
U/S Slope			
D/S Slope			
Crest			
Toe Drain			
Access Road			
Tailrace			
Headpond			
Riprap / Gabion Erosion Protection			
Vegetation			
Debris			
Other			

This page intentionally left blank.

Valens Dam Operator Spreadhseet
Total Flow Calculator

Operator's Name Initials
 Date of Visit

Water Level Calculator

Gauge Reading = (ft) Top of Control Structure = Elev m
 Gauge Reading = (m) Top of Gauge is m below deck
 Water Level = (m) Top of Gauge = = Elev = m

Flow Calculator

	Bay 1	Bay 2	Bay 3	Bay 4	Valve	
	Stoplogs	Stoplogs	Stoplogs	Stoplogs	% Open	Total Flow
Number of Stop Logs Out / Gate Opening (m)	<input type="text" value="4"/>	<input type="text" value="4"/>	<input type="text" value="4"/>	<input type="text" value="4"/>	<input type="text" value="25"/>	<input type="text"/>
Max Number of Stop Logs / Max Open	<input type="text" value="8"/>	<input type="text" value="8"/>	<input type="text" value="8"/>	<input type="text" value="8"/>	<input type="text" value="100"/>	<input type="text"/>
Estimated Flow = <input type="text"/> (cms)	<input type="text" value="1.03"/>	<input type="text" value="1.06"/>	<input type="text" value="1.06"/>	<input type="text" value="1.03"/>	<input type="text" value="0.15"/>	<input type="text" value="4.33"/>

Note: If a computer is available, use this spreadsheet to estimate the flows and enter the flows into the diary record. Otherwise, read the flows from the stage-discharge curves or the look up table.

User specified input

This page intentionally left blank.

APPENDIX B

Emergency Response and Preparedness Plans

APPENDIX B.1

Christie Lake Dams

Emergency Response and Preparedness Plans

**EMERGENCY PREPAREDNESS PLAN
Christie Lake Dam**

DISTRIBUTION			
Dam Operator	1 Copy		
HCA Administrative Office	1 Copy		
REVISIONS			
Revision	Date	Individual	Approved by



TABLE OF CONTENTS

1	INTRODUCTION.....	1-1
1.1	PURPOSE.....	1-1
1.2	AUTHORITY	1-2
1.3	CHRISTIE LAKE DAM	1-2
	1.3.1 WATER LEVELS.....	1-3
	1.3.2 AVAILABLE GAUGES	1-3
	1.3.3 ACCESS	1-3
1.4	HAZARD POTENTIAL	1-6
	1.4.1 UPSTREAM HAZARD	1-6
	1.4.2 DOWNSTREAM HAZARD.....	1-6
2	RESPONSIBILITIES.....	2-1
2.1	HCA STAFF	2-1
2.2	PRINCIPAL CONSERVATION AUTHORITY	2-1
2.3	FLOOD WARNING COORDINATOR	2-2
2.4	FLOOD PATROL OFFICERS	2-2
2.5	MUNICIPALITY	2-2
2.6	LOCAL RESPONSE COORDINATOR	2-3
3	EMERGENCY CONDITION IDENTIFICATION AND EVALUATION	3-1
3.1	FLOOD EVENT WITHOUT DAM FAILURE.....	3-1
3.2	IMMINENT DAM FAILURE	3-1
3.3	DAM FAILURE	3-2
3.4	NON-DAM FAILURE EMERGENCY	3-2
4	NOTIFICATION PROCEDURES	4-2
4.1	WARNING PROCEDURE.....	4-2
4.2	EVACUATION PROCEDURE.....	4-2
4.3	RESTRICTING ACCESS	4-2
4.4	DOCUMENTATION	4-3
4.5	HCA FLOOD CONTINGENCY PLAN	4-3
4.6	EMERGENCY CONTACT NUMBERS	4-3
4.7	DOWNSTREAM OCCUPANTS (WITHIN 0.5 KM OF THE DAM).....	4-5
5	PREPAREDNESS ACTIONS	5-1
5.1	COMMUNICATIONS.....	5-1
5.2	SURVEILLANCE	5-1
5.3	ACCESS TO THE SITE	5-1
5.4	RESPONSE DURING DARKNESS.....	5-1
5.5	RESPONSE DURING ADVERSE WEATHER	5-1
5.6	EMERGENCY SUPPLIES AND RESOURCES.....	5-1
5.7	PREVENTIVE ACTIONS	5-2
6	INUNDATION MAPS	6-1

LIST OF FIGURES

Figure #1.1. Spencer Creek Watershed 1-4
Figure #1.2. Christie Lake Dam Location Plan 1-5
Figure #4.1. Location of Downstream Properties..... 4-6

LIST OF APPENDICES

APPENDIX A - DRAWINGS

APPENDIX B - INUNDATION MAPS

1 Introduction

Christie Lake Dam is located on Spencer Creek in the Christie Lake Conservation Area, Town of Flamborough, City of Hamilton.

Under the Lakes and Rivers Improvement Act (LRIA) 2011 Technical Bulletin for Classification and Inflow Design Flood Criteria, the Hazard Potential Classification (HPC) of the Christie Lake Dam is determined as VERY HIGH and the Inflow Design Flood (IDF) is selected to be the Probable Maximum Flood (PMF). Under the LRIA 2011 Technical Bulletin for Seismic Hazard Criteria, Assessment and Considerations, the Maximum Design Earthquake (MDE) of the Christie Lake Dam is determined as the earthquake with a return period of 1:10,000 year.

As part of an overall dam safety program that is being implemented by the Hamilton Conservation Authority (HCA) and Ministry of Natural Resources (MNR), this Emergency Preparedness Plan (EPP) is prepared for Christie Lake Dam on the basis of the results of the various analyses performed and the requirements of the Canadian Dam Association (CDA) Dam Safety Guidelines (2007). From time to time, this plan may be updated. Details of the various revisions to the plan and the holders of this document are contained in the inside cover of the document. This document is site specific for Christie Lake Dam and makes reference to the HCA's Flood Contingency Plan (FCP), which is the master emergency response document of the Conservation Authority.

1.1 Purpose

According to the requirements of the CDA Dam Safety Guidelines (2007):

“In the EPP, the dam owner describes the hazards, the associated notifications to be issued, and in general terms the actions expected of other responders.”

For the normal day to day operation of the dam, the dam operator would refer to the Operation, Maintenance, Surveillance and Safety (OMSS) manual.

A comprehensive EPP is necessary to ensure that all parties responsible for water control along the watershed are involved in an action plan to ensure the safety of the public in the event of a dam emergency.

The purpose of the EPP report is to describe the procedures that should be followed and the actions that should be taken when an emergency situation is identified at the Christie Lake Dam site.

Specifically, this plan is intended to allow the dam operator (or other designated staff) to clearly identify what constitutes an emergency situation (Section 3) and details:

- HCA staff responsibilities for notification in the event of an emergency (Section 4).
- Any additional responsibilities of staff for warning or evacuating people within the immediate vicinity of the dam (Section 5).
- Locations of equipment suppliers and materials available to staff to assist in mitigating the effects of an emergency (Section 5.6)
- Drawings showing the characteristics of the dam and the inundation maps (Appendix A and Appendix B, respectively).

Characteristics of the dam and surrounding area, details of access to the site and details of the potential for flooding in the event of a dam failure are described in this section.

1.2 Authority

Under the Emergency Management Act, each Ministry must develop a Provincial Emergency Response Plan (ERP) for their assigned area of special responsibility. MNR has been designated as the lead for flood, fire, drought, dam failures, oil and gas, and landslides/subsidence/unstable slopes.

Each MNR district office has its own local ERP that ties into the MNR Provincial Plan.

This Emergency Preparedness Plan for Christie Lake Dam is developed in accordance with the CDA Dam Safety Guidelines (2007) and will form part of the HCA's Flood Contingency Plan. It is the responsibility of the Conservation Authority to operate a flood forecasting and warning system.

1.3 Christie Lake Dam

The dam is located on Spencer Creek, in the Town of Flamborough, City of Hamilton. The coordinates of the dam are 43° 16' 42" N latitude and 80° 0' 27" W longitude, or 4792202 Northing and 580531 Easting UTM Zone 17.

The dam consists of the following components:

- An earth embankment.
- A 109 m long Ogee emergency spillway with 0.60 m high (total) flashboards at the crest.
- A control structure consisting of two Ogee spillways controlled by 4.88 m x 4.88 m radial gates or 1.52 m high steel plates during the winter.

- A low flow structure (drop inlet) containing three 1.83 m wide stop log controlled bays and two 0.6 m x 0.6 m gate valves. 0.53 m high (total) stop logs are installed in each bay.

Outflow from Christie Lake Dam flows into Spencer Creek, which ultimately discharges into Lake Ontario at Hamilton Harbour.

The Spencer Creek drainage area that is controlled by the Christie Lake Dam (Figure 1.1) is approximately 153 km².

The drawings of the dam are provided in Appendix A.

1.3.1 Water Levels

The Christie Lake Dam is operated twice a year, once in the spring, when the 1.52m high steel plates are removed from the two sluiceways and the radial gates are closed to achieve the target water level of 235.01m, and once during the winter drawdown, when the steel plates are placed in the two sluiceways and the radial gates are opened to achieve the target water level of 233.17m.

1.3.2 Available Gauges

An imperial staff gauge is installed at Christie Lake Dam, which is mounted on the south wingwall of the concrete control structure on the upstream side. The staff gauge is difficult to read due to algae growth.

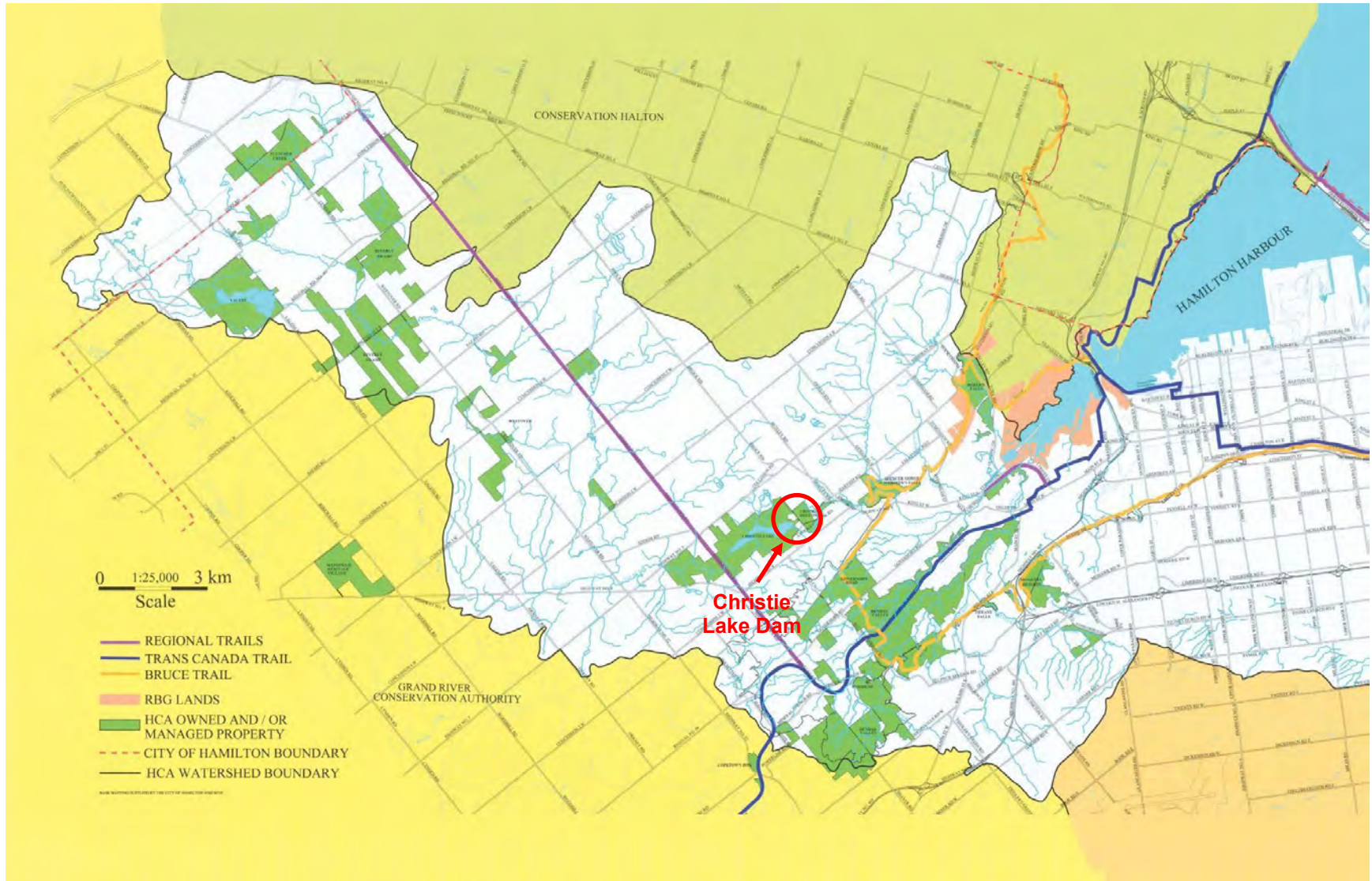
In addition to the staff gauge, there is an automatic water level gauge with data logger located inside the control room.

1.3.3 Access

Christie Lake Dam can be accessed from Crooks Hollow Road off Highway 8. The travel time is approximately a 10 minute drive from the HCA office (838 Mineral Spring Road, Ancaster, Ontario).

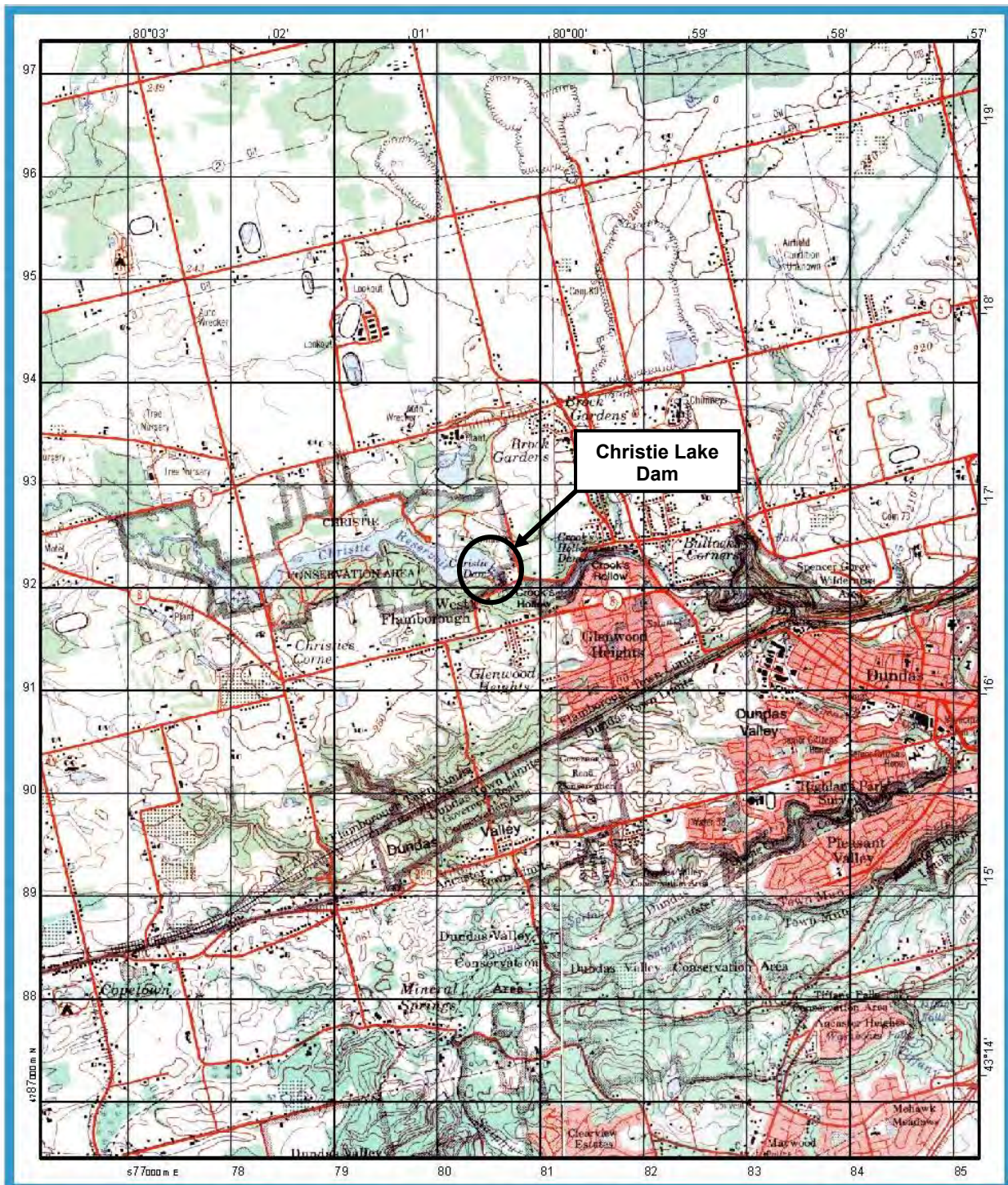
The location plan of the Christie Lake Dam is shown in Figure 1.2.

Figure 1.1. Spencer Creek Watershed

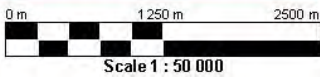


This page intentionally left blank.

Figure 1.2. Christie Lake Dam Location Plan



Produced under licences granted by Her Majesty the Queen in right of Canada, represented by the Department of Natural Resources, and by SoftMap Technologies Inc.



1.4 Hazard Potential

There are three types of hazards that can occur at the dam:

- 1) Non-Dam Failure During An Extreme Flood Event
- 2) Dam Failure During A Non-Flood Event
- 3) Dam Failure During A Flood Event

Non-dam failure during an extreme flood event is the most common type of hazard that would generally occur at this type of structure.

Failure during a non-flood event is also known as a dry weather/sunny day break. Because there is no warning with this type of failure, the potential hazard for loss of life is the highest.

A dam failure during a flood event will produce maximum upstream and downstream flood elevations, thereby increasing the potential for loss of life and property damage.

1.4.1 Upstream Hazard

The upstream hazard would be related to a non-dam failure during an extreme flood event and a dam failure during a non-flood event.

The non-dam failure during an extreme flood event could cause property damage to the surrounding conservation area from the reservoir overflow. The flood elevations along the shorelines of the reservoir are as follows (Christie Lake Dam Safety Review, 2013):

Flood Event	Flood Elevation (m)
PMF	236.79

A dam failure during a non-flood event will release the minimum flood wave at the dam and may pose a danger to those individuals that would be in close proximity of the dam. These parties may include boaters and/or fishermen immediately upstream of the dam and HCA staff.

1.4.2 Downstream Hazard

The downstream hazard can be related to all three types of dam failure.

The non-dam failure during an extreme flood event would require the release of high flows through the control structure that could cause downstream environmental and property damage. There is also potential for loss of life.

A dam failure during a non-flood event will release the minimum flood wave from the dam site and will pose a danger to those individuals that would be in close proximity of the dam. These persons may include HCA staff. There will be some downstream environmental and property damages.

Similarly, a dam failure during a flood event would produce the largest flood wave release from the dam site and will pose a threat to life for those individuals that would be in close proximity of the dam. There would definitely be downstream environmental and property damages.

2 Responsibilities

2.1 HCA Staff

HCA staff is responsible for:

- Ensuring that the equipment for communication, etc. are well maintained and in working condition, and supplies and materials needed in an emergency situation are sufficient and put in the appropriate place or are readily available from local suppliers.
- Ensuring that access to the site is maintained.
- Ensuring the safe operation of the dam if required.
- Performing routine surveillance of the dam.
- Making routine inspections of the dam for potential problems (e.g. dam body, concrete conditions, spillway, foundations, seepage and sign of failure, etc.).
- Reporting to the Manager of Water Resources Engineering of any dam deficiencies whenever they are observed.
- Identifying emergency conditions and taking appropriate action.
- Notifying the Flood Warning Coordinator for any emergency condition that is occurring or has occurred.
- Taking appropriate actions to mitigate the damages resulting from such emergency conditions.
- Notifying anyone immediately downstream of the dam that may be in immediate danger.

2.2 Principal Conservation Authority

As several Conservation Authorities may manage watercourses within the jurisdiction of an individual Regional / Municipal Government, a principal Conservation Authority has been assigned to streamline and coordinate communication with local agencies. The responsibilities of the principal Conservation Authority are:

- Coordinate communications with their assigned Municipal or Regional emergency preparedness staff and assess the need to begin the emergency response process and whether the need exists for a Regional / Municipal Emergency Operations Centre (EOC) group to assemble.
- Coordinate the assemblage and forwarding of all appropriate Conservation Authority (both Principal and Secondary) communications (flood messages) to the Regional / Municipal Emergency staff and to the Regional / Municipal EOC when opened.

- Coordinate with surrounding secondary Conservation Authorities to develop and schedule telephone conferences or discussions to ascertain specific flood related information, as well as updated weather forecast information.
- Consolidate flooding and weather information into a briefing note which will be forwarded to the representative at the Regional / Municipal EOC.
- If the Regional EOC is opened, participate at the Regional EOC and through it, assist in communicating to the Municipal EOCs.

2.3 Flood Warning Coordinator

During a flood emergency, the Flood Warning Coordinator is responsible for:

- Setting up a base of operation at the HCA Office;
- Coordination of communication with the following:
 - Local Response Coordinators at the District Offices of the Ministry of Natural Resources
 - Chief Administrative Officer of the HCA
 - Chair and / or Vice Chair of the HCA
 - Flood Emergency Coordinator of each Municipality
 - HCA Flood Patrol Officers
 - News Media
- Requesting provincial assistance through the Provincial/Local Response Coordinator of the Ministry of Natural Resources, when requested by the municipality, if area and regional action is insufficient to meet a flood emergency.

The Flood Warning Coordinator will be assisted by HCA Flood Patrol Officers and the Telephone Operator.

2.4 Flood Patrol Officers

During an emergency situation, HCA staff members having a detailed knowledge of certain watercourses will be assigned to specific areas to assess situations and will report problems or possible problem areas to the base of operation.

2.5 Municipality

Municipalities have the primary responsibility for response to flood emergencies, and also for the welfare of residents and protection of property. Upon receiving a Flood Advisory or Flood Warning, municipalities shall:

- Notify appropriate municipal officials, departments and agencies in accordance with their municipal emergency plan.
- Determine the appropriate response and if warranted, deploy municipal resources.
- If required, declare a flood emergency and implement their Emergency Procedures Plan.
- Request provincial assistance if municipal resources are inadequate.
- Communicate with Conservation Authority Flood Coordinators.

2.6 Local Response Coordinator

The local Response Coordinator is the District Manager of the Ministry of Natural Resources. The local Response Coordinator is responsible for:

- Alerting HCA regarding general provincial alerts.
- Alerting key MNR personnel and other Government Ministries which may be required for assistance.
- Assessing the flood situation, in conjunction with HCA and adjacent Conservation Authorities.
- Responding to a request by a municipality for provincial assistance should the total resources of the municipality be committed or inadequate and the municipality has declared an emergency situation.
- Coordinating the delivery of the provincial response in a declared emergency.

3 Emergency Condition Identification and Evaluation

Emergency conditions that might occur are described as follows:

3.1 Flood Event Without Dam Failure

HCA staff shall follow the requirements of the Operation, Maintenance, Surveillance and Safety (OMSS) Manual until all of the actions to control flows have been exhausted. If the water level in the lake is rising, or is forecast to rise, above 237.81m (overflow spillway concrete walkway elevation), the operator should follow the procedures described herein for imminent dam failure.

3.2 Imminent Dam Failure

Dam failure results in a sudden release of impounded water. The resulting flood hydrograph peak due to the dam failure may be very high, leading to flood damages. The amount of warning time available in the event of an unexpected failure of the concrete structures or earth embankment is difficult to quantify. For example, it is unlikely a slight overtopping of the structure would result in a catastrophic failure event. Therefore, it is not possible to use water level as a warning indication. It is more likely that failure would occur as a result of structural or foundation problems. Such failures typically occur very rapidly, often in a matter of minutes. Dam failures are often preceded by warning signs such as increasing leakage or cracking. Therefore, routine monitoring will significantly reduce the risk of an unexpected failure.

A dam failure is usually preceded by warning signs that indicate the dam, the foundation, or the control structure is deteriorating. For Christie Lake Dam, which consists of an earth embankment and a concrete structure, such signs which may occur include:

- Increased seepage.
- Whirlpool development in the reservoir.
- Appearance of new springs or boils downstream of the dam.
- Appearance of new cracks or extension of existing cracks.
- Visible signs of distress, such as movement of a part of a dam or slumping.

During regular site inspections, HCA staff is responsible for identifying any such warning signs and notifying the Manager of Water Resources Engineering and, if an emergency appears imminent, the Flood Warning Coordinator. If during an inspection, HCA staff discovers something unusual that he/she is not familiar with, the Manager of Water Resources Engineering should be contacted immediately for advice. An emergency should not be ruled out unless it can be determined that it is not an emergency.

3.3 Dam Failure

Should Christie Lake Dam fail, the downstream consequences would be:

- Potential loss of life at the residences located downstream of the dam.
- Damage to the CNR embankment, the roads, and the respective culverts and bridges.
- Environmental damage along Spencer Creek downstream of the dam.
- Residential and property damage downstream of the dam.
- Flooding of agricultural and park lands.

3.4 Non-dam Failure Emergency

These might include:

- Boating accident
- Swimming accident
- Personal injury

In such a case, HCA staff may contact the local emergency medical response authorities (telephone 911), and the Manager of Water Resources Engineering.

For specific problems, evaluation and notification procedures, data to record and actions to follow are indicated in the Emergency Action Table (EAT).

Problem	How to Evaluate	Notification	Data to Record	Action
Flooding	<ul style="list-style-type: none"> Water level exceeds 237.45m 	Flood Warning Coordinator HCA	<ul style="list-style-type: none"> Water discharge, headwater, tailwater elevations and rate of change Weather conditions Photographs Dam condition 	<ul style="list-style-type: none"> Follow Operation, Maintenance, Surveillance & Safety (OMSS) manual procedures to open all outlets until water level begins to recede. If water level continues to rise after all outlets are open, follow procedure for imminent dam failure.
	<ul style="list-style-type: none"> Water level exceeds top of dam at elevation 237.81m 	Flood Warning Coordinator HCA Warn anyone in immediate area	<ul style="list-style-type: none"> Water discharge, headwater, tailwater elevations and rate of change Weather conditions Photographs Dam condition 	<ul style="list-style-type: none"> Follow OMSS manual procedures to open outlets to maximum safe capacity to lower water levels. In consultation with Flood Warning Coordinator, create additional spill capacity by controlled breach of dam. Follow procedures for Imminent Dam Failure.
Imminent Dam Failure	<ul style="list-style-type: none"> Excessive Seepage Whirlpool in Headpond Extensive Cracking Boils or Springs Downstream Discharge of Fines Movement of Dam 	Flood Warning Coordinator HCA Warn anyone in immediate area	<ul style="list-style-type: none"> Water discharge, headwater, tailwater elevations and rate of change Weather conditions Photographs Dam condition 	<ul style="list-style-type: none"> Restrict Access Follow OMSS manual procedures to open outlets to maximum safe capacity to lower water levels. Plug boils or springs with any available materials. Stabilize dam by placing soil in toe area.
Dam Failure	<ul style="list-style-type: none"> Dam Breached 	Flood Warning Coordinator HCA Warn anyone in immediate area	<ul style="list-style-type: none"> Water discharge, headwater, tailwater elevations and rate of change Weather conditions Photographs Description and location of dam breach 	<ul style="list-style-type: none"> Restrict Access
Non-dam Emergency	<ul style="list-style-type: none"> Swimming Emergency Boating Accident Personal Injury 	Emergency Medical Response Team 911 Director of Engineering and Technical Services HCA	<ul style="list-style-type: none"> Nature of Problem Photographs Names Cause(s) of accident Length of time for response 	<ul style="list-style-type: none"> Follow standard procedures for First Aid

4 Notification Procedures

In the event that an emergency situation is identified, HCA staff must inform the Flood Warning Coordinator.

The Flood Warning Coordinator will be responsible for notifying the Local Response Coordinator of the MNR and all other agencies required. The Flood Warning Coordinator and the Local Response Coordinator will assess the level of the emergency condition and the appropriate actions that should be taken to mitigate the potential damages.

Depending on the type of emergency or emergency conditions, other contacts and actions may be required.

4.1 Warning Procedure

- For a flood event where the water level is lower than 236.79m, no flood warning is required.
- For a flood event where the water level is higher than 236.79m, a warning should be issued by the Flood Warning Coordinator.
- For a dam failure event, the dam operator should issue an immediate warning to downstream residents and any residents in the immediate vicinity of the dam.

The Flood Warning Coordinator will be responsible for issuing a flood emergency warning through the news media. Immediate warnings to the public can be initiated with the assistance of the OPP.

4.2 Evacuation Procedure

During an extreme flood and/or a dam failure event, evacuation in the potential inundation area downstream along the Spencer Creek may be necessary. An evacuation order should be coordinated through the OPP by the Flood Warning Coordinator.

4.3 Restricting Access

In the event of an emergency, restricting access to the flooded area may be required for public safety. This can be accomplished by closing the access road to the dam and any other downstream local roads. This should also be coordinated through the OPP.

4.4 Documentation

All reports or journal entries should include the following information:

- Current water levels.
- Rate of water level change.
- Actions that have been taken.
- Who has been informed.
- Estimated dam discharge.
- Date, time and weather conditions.
- Author of the report.
- Photographic record.

4.5 HCA Flood Contingency Plan

This Christie Lake Dam EPP is to be carried out in concert with the HCA Flood Contingency Plan (FCP).

The HCA FCP contains detailed procedures to be followed by various parties in the event of extreme weather with flooding potential. The HCA FCP also contains additional contact numbers for use by the Flood Warning Coordinator.

4.6 Emergency Contact Numbers

- | | | | |
|----|---|------------------|--|
| 1. | Water Resources Engineering: | Jonathan Bastien | BUS: 905-525-2181
Ext. 138
FAX: 905-648-4622
CEL:
RES: |
| 2. | Manager of Water Resources Engineering: | Hazel Breton | BUS: 905-525-2181
Ext. 137
FAX: 905-648-4622
CEL:
RES: |

- | | | | |
|----|--|--------------|--|
| 3. | Chief Administrative Officer: | | BUS: 905-525-2181
Ext.
FAX: 905-648-4622
CEL:
RES: |
| 3. | Regional Engineer
Southern Region, MNR: | Mark Stephen | BUS: 705-755-3200 |
| 4. | Area Supervisor,
Guelph District, MNR: | | BUS:
RES: |
| 5. | Provincial Response Centre: | | BUS: 705-945-5750
FAX: 705-945-5785 |
| 6. | Ontario Provincial Police: | | TEL: 888-310-1122 |
| 7. | Medical Emergencies: | | TEL: 911 |

Refer to the HCA Flood Contingency Plan for additional emergency contact numbers.

Figure 4.1. Location of Downstream Properties

5 Preparedness Actions

5.1 Communications

Communication equipment must be kept in working order and ready to be used at any time during flood season. There is telephone communication at the Conservation Area office. HCA staff has access to portable radios and cellular phones to be used for regular duties and for emergencies.

5.2 Surveillance

The surveillance procedure described in the OMSS manual should be followed.

5.3 Access to the Site

The dam can be accessed from Crooks Hollow Road off Highway 8.

5.4 Response During Darkness

HCA staff will require battery-operated lights. They should be well maintained, kept in working condition and routinely checked. If an emergency situation occurs during periods of darkness, HCA staff should follow the same procedures that are described in the Emergency Action Table.

5.5 Response During Adverse Weather

The response to emergency conditions during adverse weather could include extremes of cold, snow, ice and storms. Special precautions when responding to an emergency under these conditions would include:

- Tools to clear structure access of ice and snow
- Sand for a slippery deck
- Extra dry clothes
- Knowledge of symptoms of hypothermia
- Personal safety/floatation devices

5.6 Emergency Supplies and Resources

In the event of an emergency, supplies (such as rock fill), equipment (such as backhoes and bulldozers) and personnel may be required. Locations and contact numbers are provided in the HCA FCP.

No life rings are available on-site.

A first-aid kit is located in every HCA vehicle.

5.7 Preventive Actions

Preventive actions include, but are not limited to, the installation of equipment and/or the establishment of procedures for one or more of the following purposes:

- Preventing emergency conditions from developing, if possible, or warning of the development of emergency situations.
- Facilitating emergency measures at the dam to limit impacts in an emergency situation.
- Minimizing the extent of damage resulting from any emergency situation that does develop.

Every emergency situation is unique or has unique features, just as every dam has unique characteristics and conditions. Therefore, there are no preventive actions that can be prescribed for all cases. However, the following are some examples of actions that may help alleviate certain failure scenarios. These examples are generic in nature and are by no means all-inclusive.

Potential Overtopping of Dam by Flood Waters:

- 1) Open the radial gates and the low flow gates to maximum capacity and remove as many stop logs as possible, as well as the flashboards.
- 2) Place sandbags along the crest to increase freeboard and force more water through the outlet.
- 3) Create additional spillway capacity by making a controlled breach in a low embankment section where the foundation materials are erosion resistant.
CAUTION: Use only as a last resort.

Reduction in Freeboard and/or Loss of Dam Crest Width:

- 1) Lower the water level to an elevation below the damaged area through opening the radial gates and the low flow gates and removing stop logs.
- 2) Place additional riprap or sandbags in damaged areas to prevent further erosion.
- 3) Restore freeboard with sandbags or earth and rockfill.
- 4) Continue close inspection of the damaged area until the storm is over.

A Slide on the Upstream or Downstream Slope of the Embankment:

- 1) Lower the water level at a rate and to an elevation that is considered safe given the slide condition. If the discharge outlets are damaged or blocked, pumping, siphoning, or controlled breach may be required.
- 2) Restore lost freeboard if required by placing sandbags or filling in the top of the slide.
- 3) Stabilize slides on the downstream slope by weighing the toe area with additional soil, rock or gravel.

Erosion, Seepage or Leakage (Piping) through the Embankment, Foundation or Abutments:

- 1) Identify extent of erosion or area(s) of seepage and color of effluent.
- 2) Lower the water level by whatever means possible (e.g. open the radial gates and the low flow gates, remove stop logs, pumping, etc.) until the flow decreases to a non-erosive velocity or until it stops.
- 3) Plug the flow with whatever material is available (e.g. hay bales, bentonite or plastic sheeting if the entrance to the leak is in the reservoir).
- 4) Place a blanket filter (i.e. a protective sand and gravel filter) over the exit area to hold material in place.
- 5) Continue lowering the water level until a safe elevation is reached.
- 6) Continue operating at a reduced level until repairs are made. Never leave the site unattended until the situation is under control.

A Failure of an Appurtenant Structure such as an Outlet or Spillway:

- 1) Implement temporary measures to protect the damaged structure, such as closing an outlet or providing temporary protection for a damaged spillway.
- 2) Employ experienced professional divers if necessary to assess the problem and possibly implement repairs.
- 3) Lower the water level to a safe elevation. If the outlets are inoperable, pumping, siphoning or a controlled breach may be required.

A Mass Movement of the Dam on its Foundation (Spreading or Mass Sliding Failure):

- 1) Immediately lower the water level by whatever means possible until excessive movement stops.
- 2) Continue lowering the water level until a safe level is reached.
- 3) Continue operation at a reduced level until repairs are made.

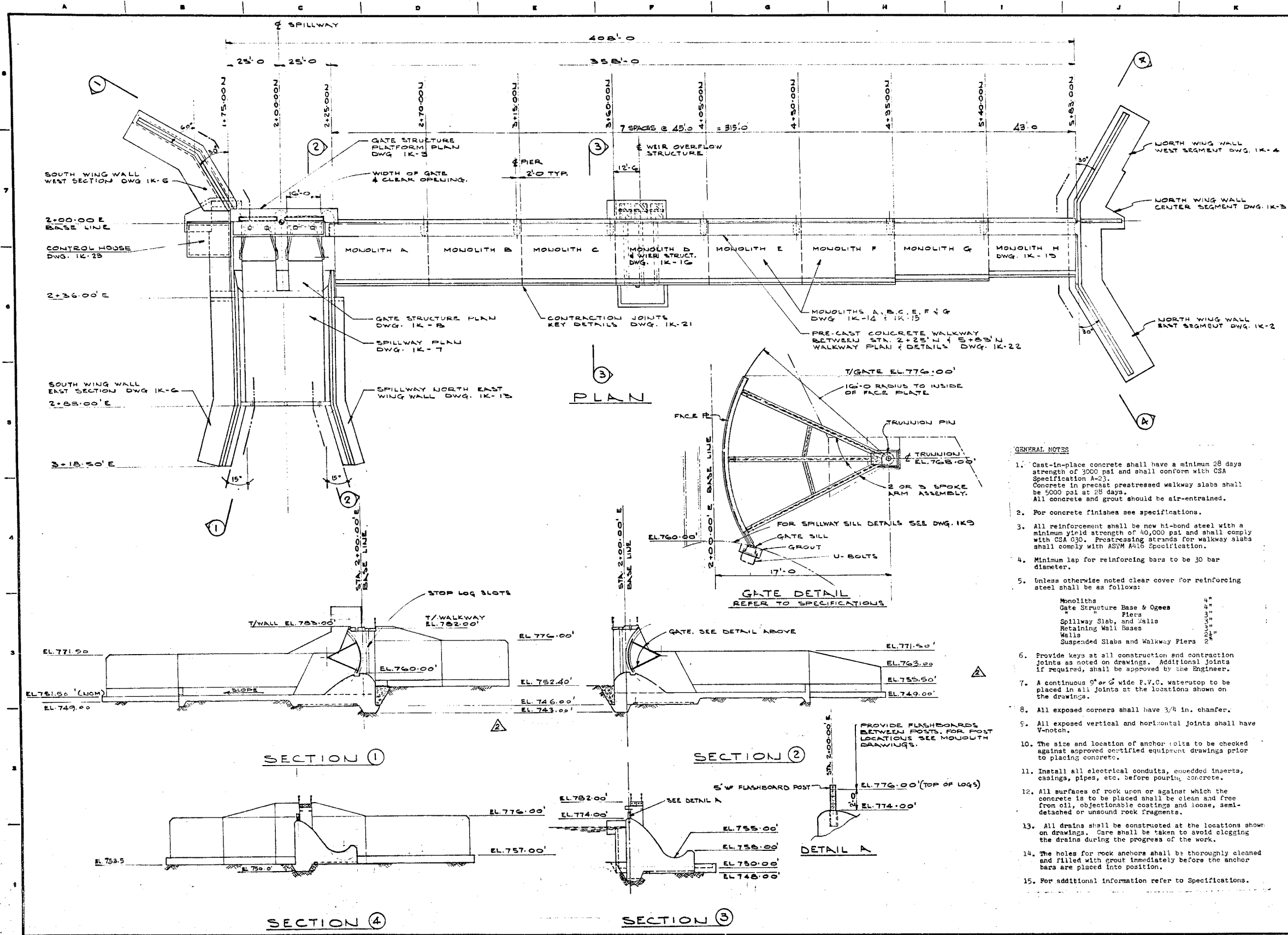
6 Inundation Maps

Determination of the Hazard Potential Classification (HPC) of a dam requires an incremental hazard assessment. The assessment assists in the determination of the Inflow Design Flood (IDF). As a by-product of the assessment, inundation maps are prepared to illustrate the extent of flooding under various dam break scenarios and the IDF.

A dam break analysis was undertaken, in which the Christie Lake Dam HPC was determined to be VERY HIGH and the IDF was selected as the Probable Maximum Flood (PMF). Flood inundation maps for the Sunny Day and IDF failures were prepared and are attached in Appendix B.

APPENDIX A - DRAWINGS

This page intentionally left blank.

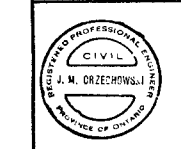


REFERENCE DRAWINGS		
DAMSITE TOPOGRAPHY	C-1	
WORK AREA ACCESS	C-2	
GENERAL PLAN	C-3	
ELEVATION	C-4	
GRADING & SPILLWAY SHT. 1	C-5	
" " " " SHT. 2	C-6	
" " " " SHT. 3	C-7	
ROUTING & DRAINAGE	C-8	
NORTH BATHILL SEGMENT	C-9	
SOUTH BATHILL SEGMENT	C-10	
SPILLWAY CHANNEL	C-11	
FENCE & HANDRAIL DETAILS	C-12	

NO.	DATE	REVISIONS	LOC.	BY
1	JUN 1968	CONCRETE ELEV. ALTERED TO SUIT ROCK ELEVATIONS		
2		CONTROL HOUSE ADDED		

- GENERAL NOTES**
- Cast-in-place concrete shall have a minimum 28 days strength of 3000 psi and shall conform with CSA Specification A-23. Concrete in precast prestressed walkway slabs shall be 5000 psi at 28 days. All concrete and grout should be air-entrained.
 - For concrete finishes see specifications.
 - All reinforcement shall be new hi-bond steel with a minimum yield strength of 40,000 psi and shall comply with CSA G30. Prestressing strands for walkway slabs shall comply with ASTM A116 Specification.
 - Minimum lap for reinforcing bars to be 30 bar diameter.
 - Unless otherwise noted clear cover for reinforcing steel shall be as follows:

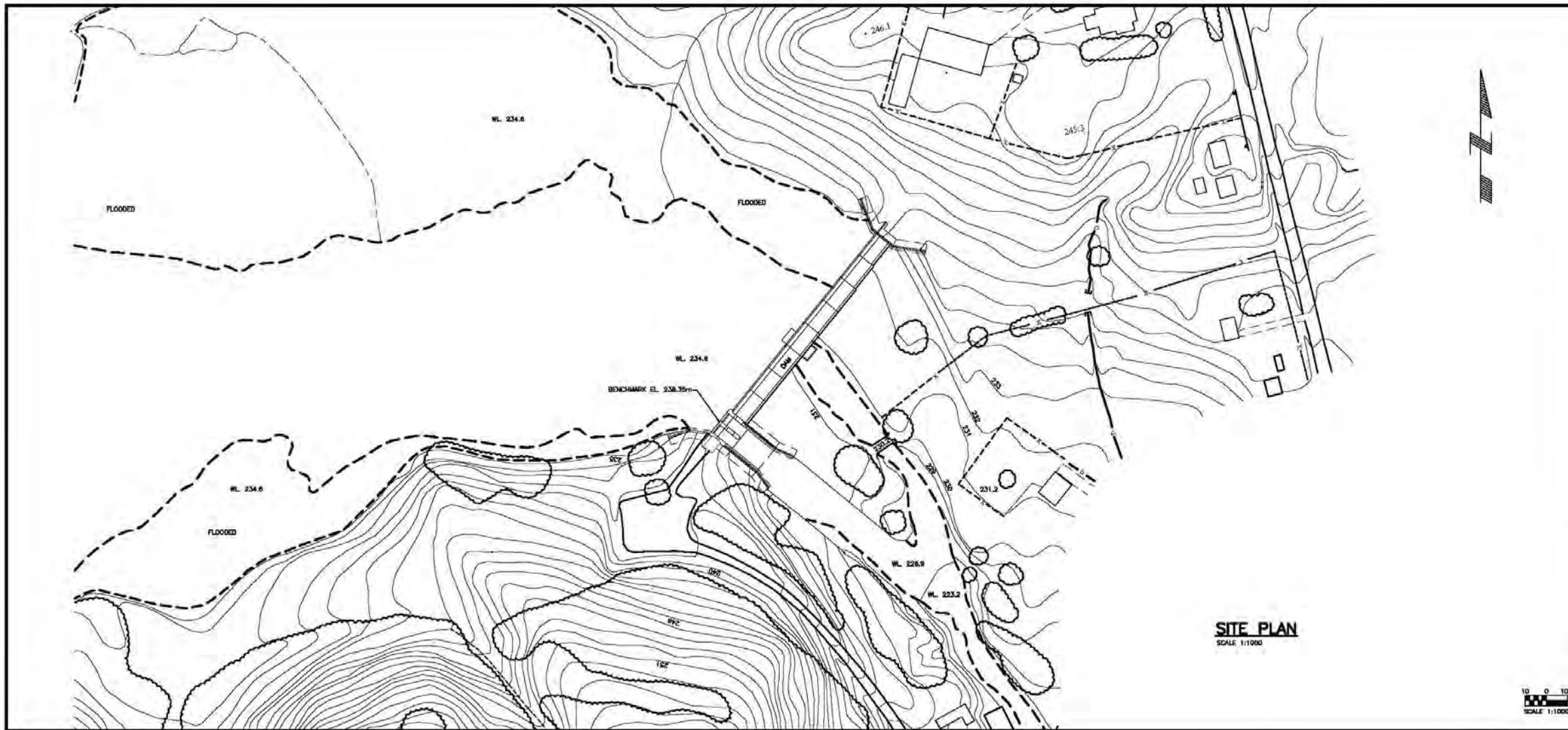
Monoliths	4"
Gate Structure Base & Ogee	4"
Piers	3"
Spillway Slab, and Walls	3"
Retaining Wall Bases	3"
Walls	2 1/2"
Suspended Slabs and Walkway Piers	2"
 - Provide keys at all construction and contraction joints as noted on drawings. Additional joints if required, shall be approved by the Engineer.
 - A continuous 6" or 8" wide P.V.C. watertop to be placed in all joints at the locations shown on the drawings.
 - All exposed corners shall have 3/4 in. chamfer.
 - All exposed vertical and horizontal joints shall have V-notch.
 - The size and location of anchor bolts to be checked against approved certified drawings prior to placing concrete.
 - Install all electrical conduits, embedded inserts, casings, pipes, etc. before pouring concrete.
 - All surfaces of rock upon or against which the concrete is to be placed shall be clean and free from oil, objectionable coatings and loose, semi-detached or unsound rock fragments.
 - All drains shall be constructed at the locations shown on drawings. Care shall be taken to avoid clogging the drains during the progress of the work.
 - The holes for rock anchors shall be thoroughly cleaned and filled with grout immediately before the anchor bars are placed into position.
 - For additional information refer to Specifications.



HAMILTON REGION CONSERVATION AUTHORITY
 HAMILTON ONTARIO
CHRISTIE DAM PROJECT
 DAM STRUCTURE
 REFERENCE PLAN AND SECTIONS
FENCO
FOUNDATION OF CANADA ENGINEERING CORPORATION LIMITED

SCALE 1/4" = 20 FT
 DRAWING NUMBER 3251-1K-1
 SHEET 2





SITE PLAN
SCALE 1:1000



- GENERAL SPECIFICATIONS**
- THE DESIGN AND CONSTRUCTION OF THIS PROJECT IS TO CONFORM TO THE REQUIREMENTS OF THE NATIONAL BUILDING CODE OF CANADA - 1980, AND THE ONTARIO BUILDING CODE, 1987, AS AMENDED, AND THE CODES & STANDARDS PROVIDED FOR THE RESPECTIVE ITEMS.
 - PRIOR TO PROCEEDING WITH THE WORK, THE CONTRACTOR SHALL CHECK AND VERIFY ALL DIMENSIONS, ELEVATIONS AND CONDITIONS AT SITE AND REPORT TO THE ENGINEER ANY DISCREPANCIES OR UNSATISFACTORY CONDITIONS WHICH MAY AFFECT THE PROPER EXECUTION OF THE WORK AND THE COMPLETION OF THE PROJECT.
 - MATERIALS SHALL MEET THE FOLLOWING STANDARDS:
 DESIGN OF CONCRETE STRUCTURES, CSA-A23.3-04/00.
 LIMIT STATES DESIGN FOR STEEL STRUCTURES, CSA-S16.1-01.
 COLD FORMED STEEL STRUCTURAL MEMBERS, CAN/CSA-S130-01.
 MASONRY DESIGN FOR BUILDINGS, CSA-S304.1-04/01.
 CONCRETE MATERIALS AND METHODS OF CONCRETE CONSTRUCTION, CSA-A23.1-00.
 METHODS OF TESTING FOR CONCRETE, CSA-A23.2-00.
 ENGINEERING DESIGN IN WOOD, CSA-O86.1-01.
 STRUCTURAL QUALITY STEELS, CAN/CSA-G40.21-M88.
 GENERAL REQUIREMENTS FOR ROLLED OR WELDED STRUCTURAL QUALITY STEEL, CAN/CSA-G40.20-M88.
 WELDED STEEL CONSTRUCTION (METAL ARC WELDING), CSA-W59-M03.
 BULLET STEEL BARS FOR CONCRETE REINFORCEMENT, CAN/CSA-G30.18-M92/00.
 WELDED STEEL WIRE FABRIC FOR CONCRETE REINFORCEMENT, CAN/CSA-G30.18-M92/00.
 WELDING ELECTRODES CSA-W48.1-M01 TO CSA-W48.6-01; STAINLESS STEEL - E316.
 - REFER TO GENERAL CONSTRUCTION SPECIFICATIONS DRAWINGS 10, 11, 12 & 13
 - BENCHMARK AT CONTROL STRUCTURE WALKWAY EL. 238.35M

NO.	REVISION	DATE	APPROVED
1	AS BUILT	JULY 2004	
0	ISSUED FOR CONSTRUCTION	MAR 2004	
B	ISSUED FOR TENDER	FEB 2004	
A	ISSUED FOR APPROVAL	JAN 2004	

SCALE

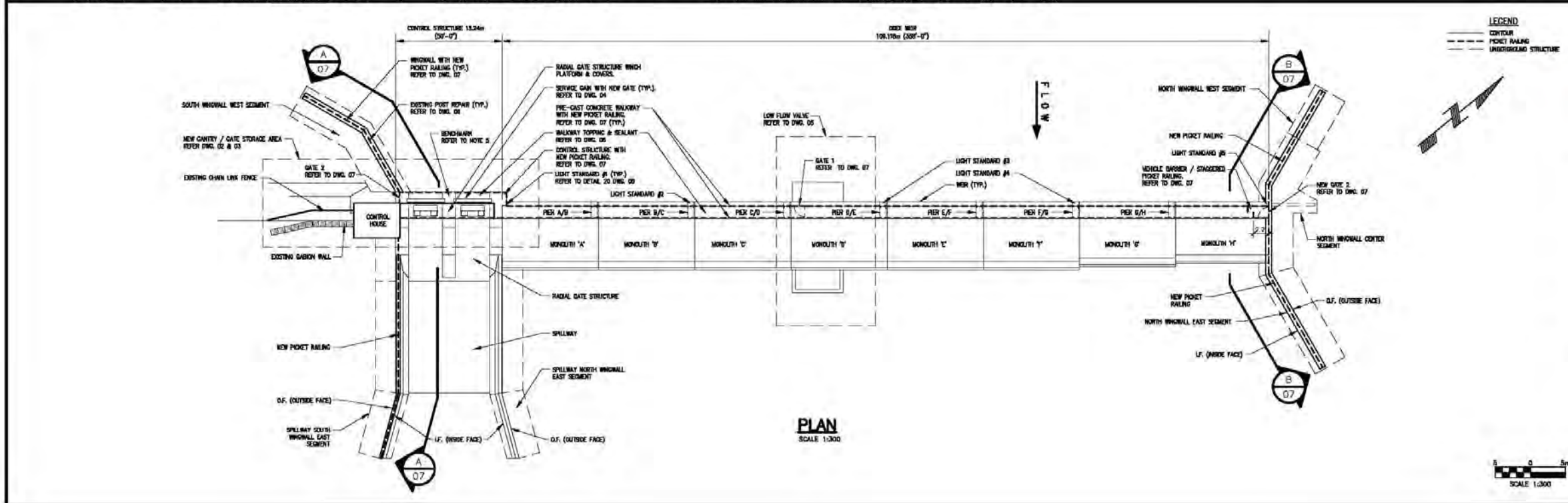
DESIGNED BY: _____
 CHECKED BY: _____
 DATE: _____



Trow Associates Inc.
 1695 Clark Boulevard
 Brampton, Ontario L7T 4V1
 Trow
 FAX (905) 783-0841 TEL (905) 783-0800

PROJECT: **CHRISTIE LAKE DAM**
 LOCATION: **HAMILTON, ONTARIO**
 TROW PROJECT NO: **0069210A**
 DRAWING TITLE: **SITE & DAM PLAN**

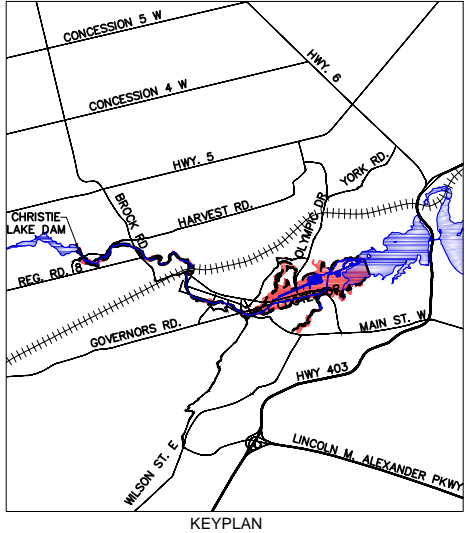
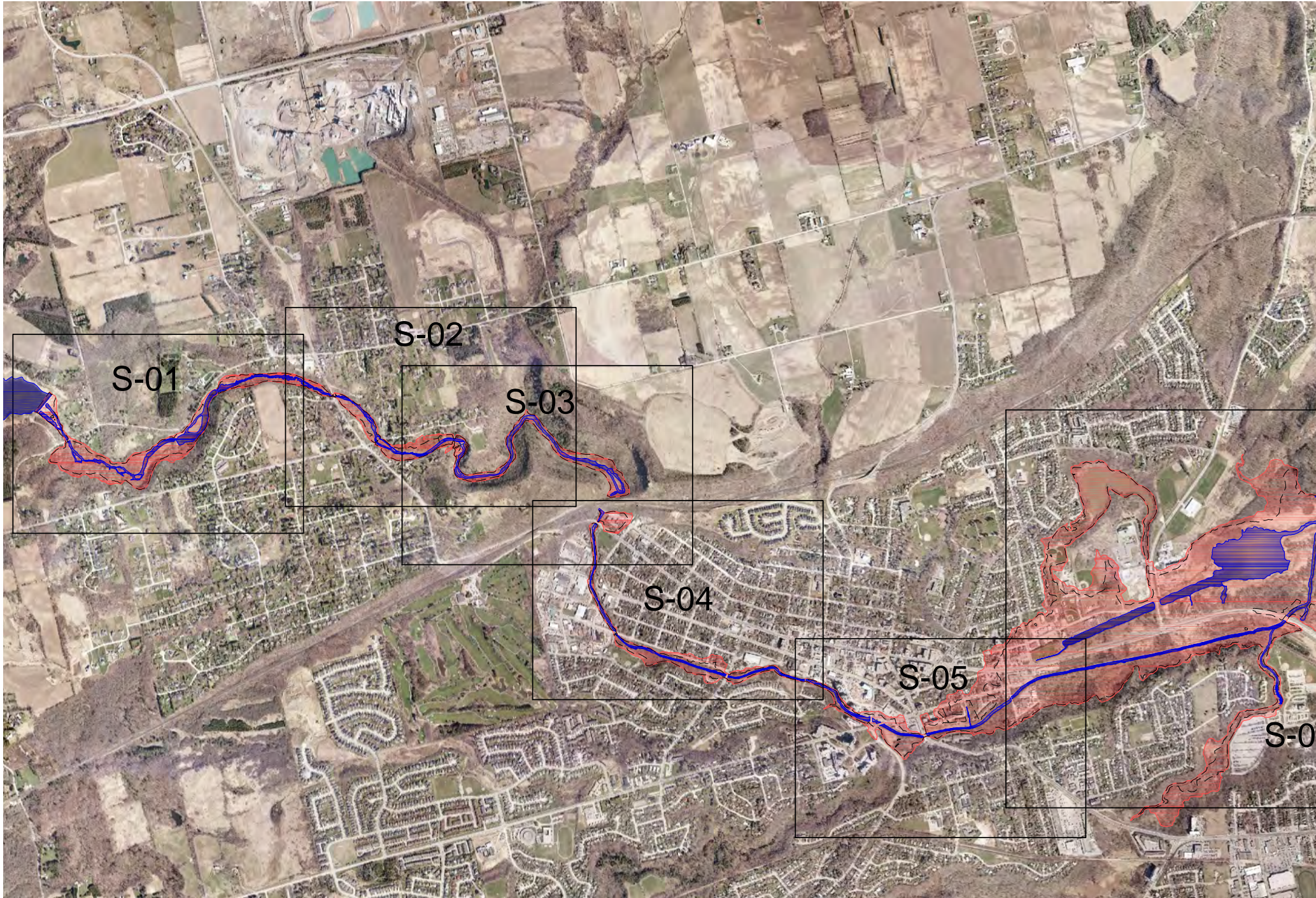
SCALE	DATE
AS NOTED	MARCH 2004
DRAWN BY: M.S.A.	REV. NO. 0
DESIGNED BY: M.M.N.	DRAWING NO. 01
CHECKED BY: G.T.	



PLAN
SCALE 1:300

APPENDIX B - INUNDATION MAPS

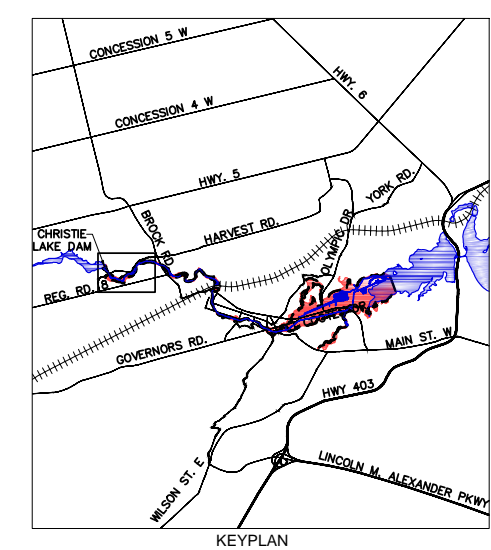
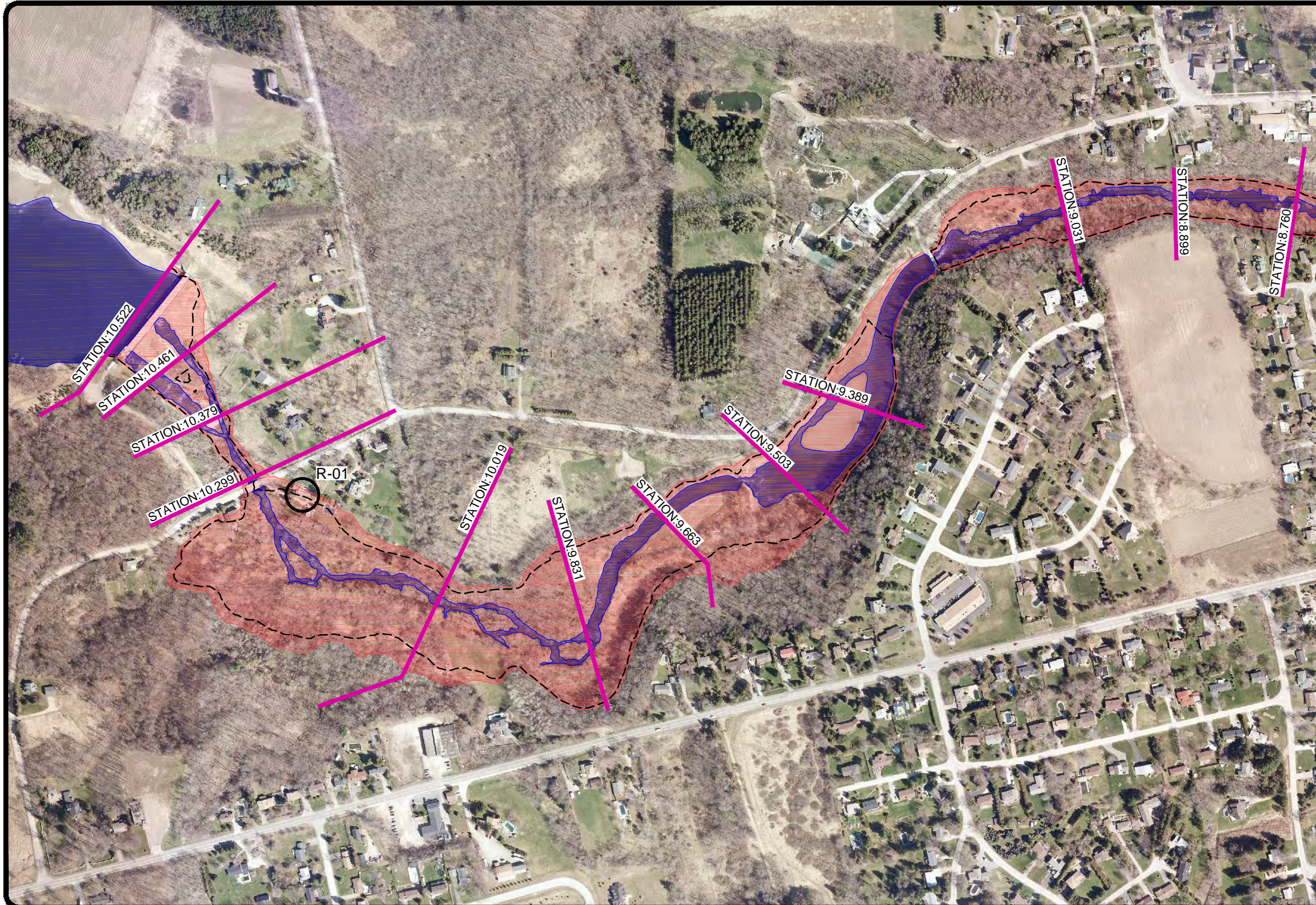
This page intentionally left blank.



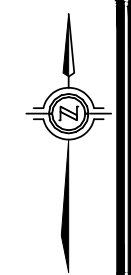
- LEGEND**
- LOCATION OF CROSS SECTION
 - NORMAL SUMMER WATER LEVEL
 - LIMIT OF INUNDATION DUE TO DAM FAILURE
 - 0.8m INUNDATION DEPTH (MIN.) DUE TO DAM FAILURE



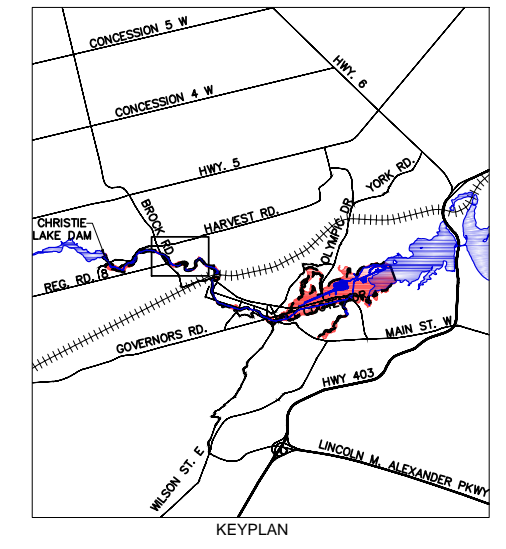
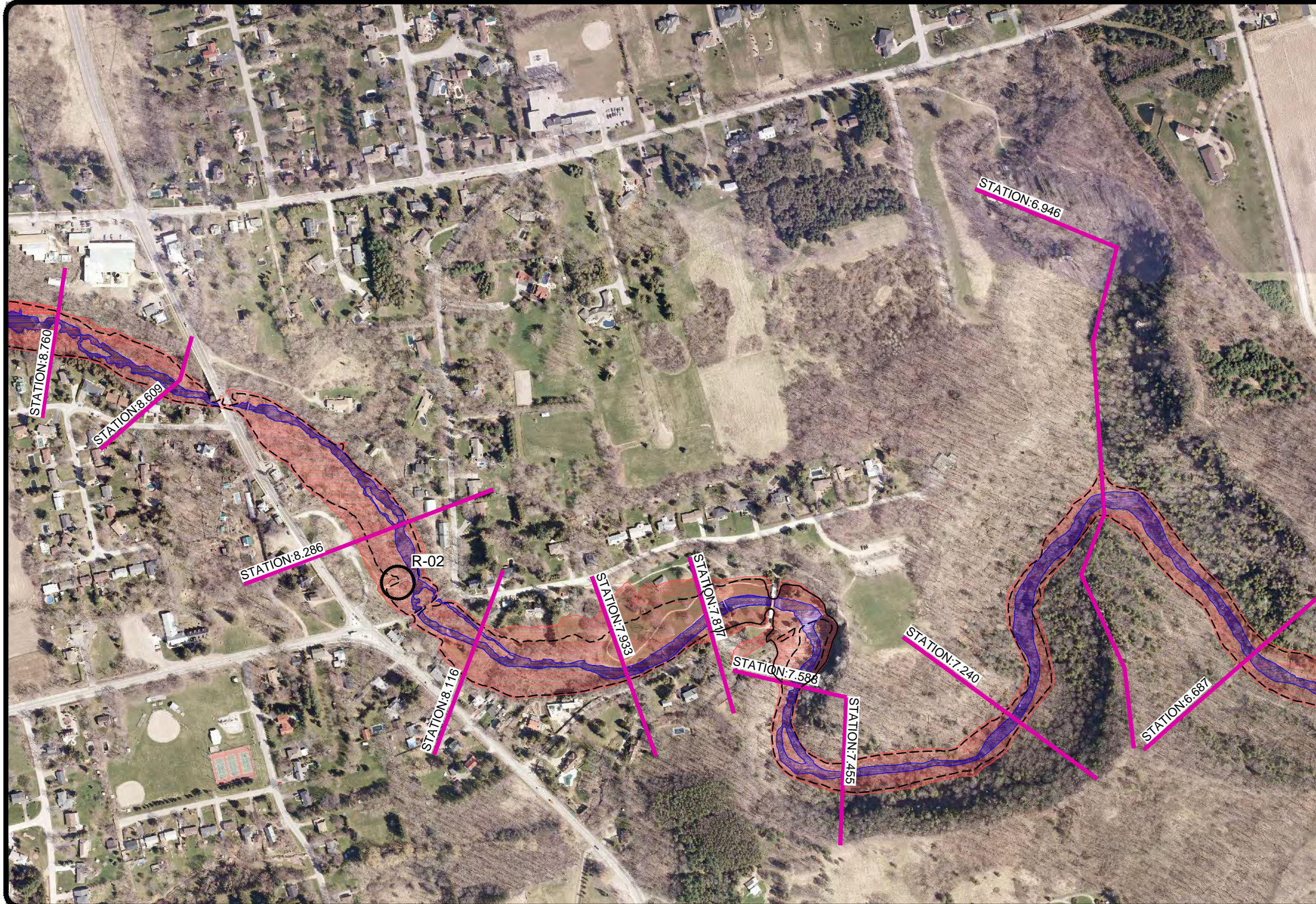
Project:		CHRISTIE LAKE DAM DAM SAFETY REVIEW	
Title:		SUNNY DAY CONDITION (GENERAL PLAN)	
Approved by:	S.K.	Date:	MAR. 18/2013
Project No.:	BRM00600601b		
Drawn by:	M.B.S.	Scale:	1:25000
Figure no.:	S-00 200		



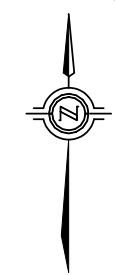
LEGEND
 — LOCATION OF CROSS SECTION
 ■ NORMAL SUMMER WATER LEVEL
 ■ LIMIT OF INUNDATION DUE TO DAM FAILURE
 ■ 0.8m INUNDATION DEPTH (MIN.) DUE TO DAM FAILURE
 ○ R-00 BUILDING WITHIN INUNDATION AREA



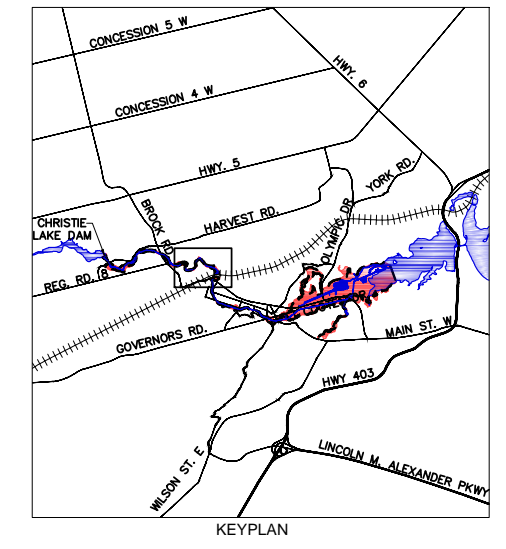
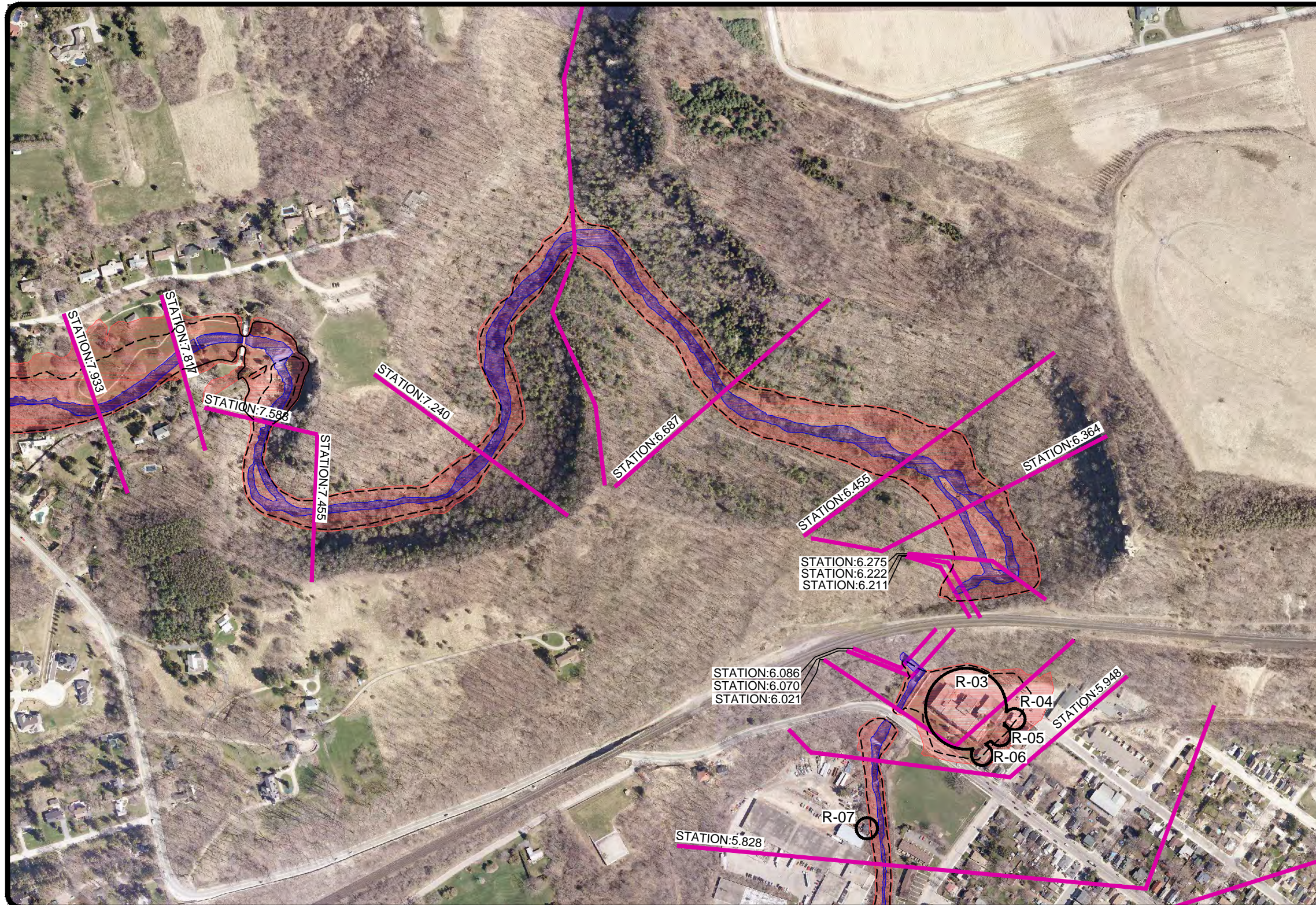
Project:			CHRISTIE LAKE DAM DAM SAFETY REVIEW
Title:			SUNNY DAY CONDITION INUNDATION MAP
Approved by:	S.K.	Date:	MAR. 18/2013
Project No.:	BRM00600601b		
Drawn by:	M.B.S.	Scale:	1:5000
Figure no.:	S-01 204		



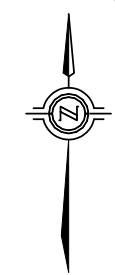
- LEGEND**
- LOCATION OF CROSS SECTION
 - NORMAL SUMMER WATER LEVEL
 - LIMIT OF INUNDATION DUE TO DAM FAILURE
 - 0.8m INUNDATION DEPTH (MIN.) DUE TO DAM FAILURE
 - R-00 BUILDING WITHIN INUNDATION AREA



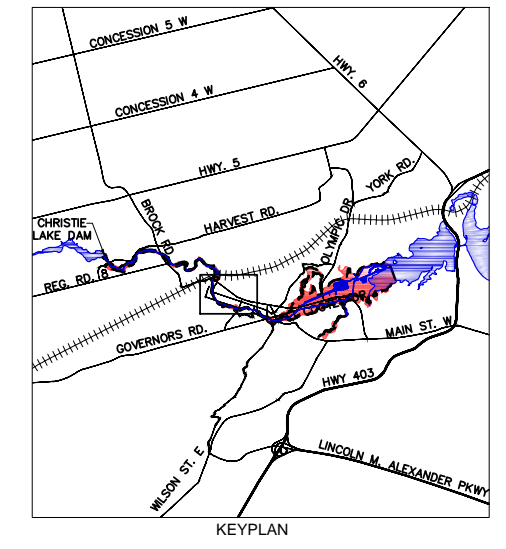
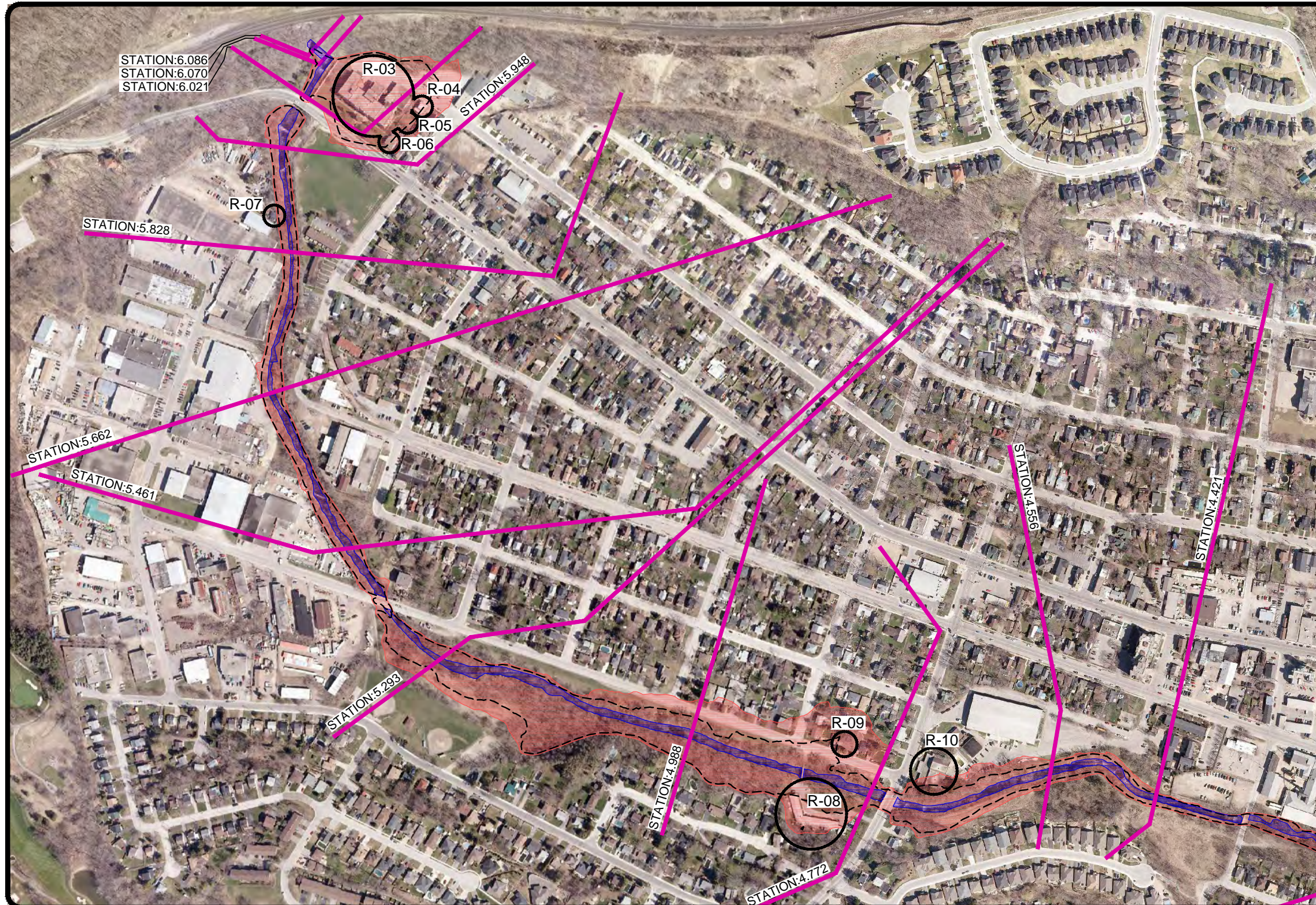
Project:			CHRISTIE LAKE DAM DAM SAFETY REVIEW
Title:			SUNNY DAY CONDITION INUNDATION MAP
Approved by:	S.K.	Date:	MAR. 18/2013
Project No.:	BRM00600601b		
Drawn by:	M.B.S.	Scale:	1:5000
Figure no.:	S-02 205		



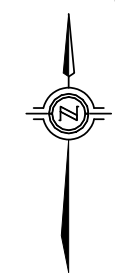
- LEGEND**
- LOCATION OF CROSS SECTION
 - NORMAL SUMMER WATER LEVEL
 - LIMIT OF INUNDATION DUE TO DAM FAILURE
 - 0.8m INUNDATION DEPTH (MIN.) DUE TO DAM FAILURE
 - R-00 BUILDING WITHIN INUNDATION AREA



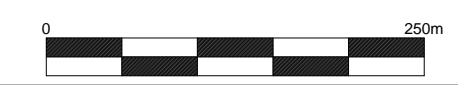
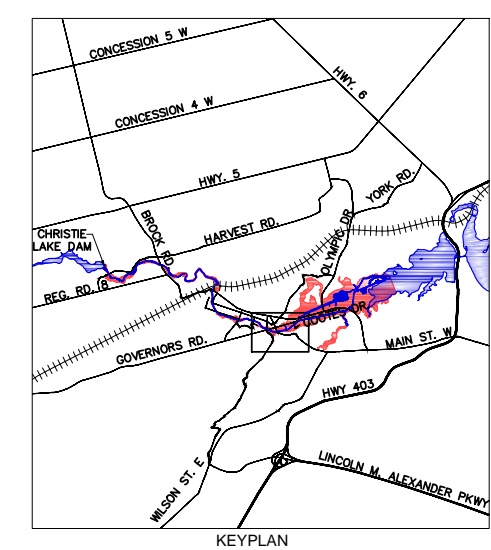
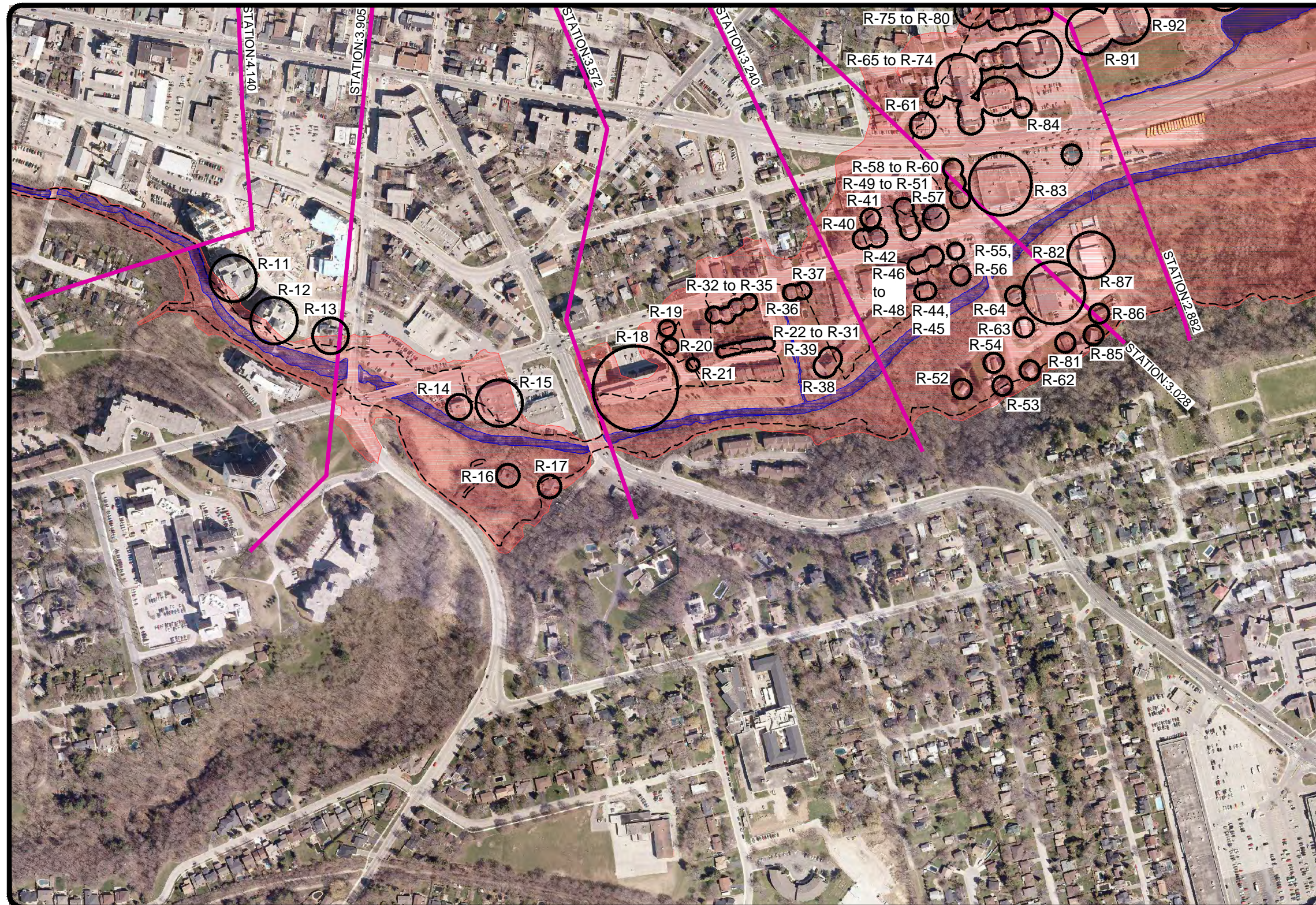
Project:		CHRISTIE LAKE DAM DAM SAFETY REVIEW	
Title:		SUNNY DAY CONDITION INUNDATION MAP	
Approved by:	S.K.	Date:	MAR. 18/2013
Project No.:	BRM00600601b		
Drawn by:	M.B.S.	Scale:	1:5000
Figure no.:	S-03 206		



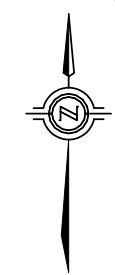
- LEGEND**
- LOCATION OF CROSS SECTION
 - NORMAL SUMMER WATER LEVEL
 - LIMIT OF INUNDATION DUE TO DAM FAILURE
 - 0.8m INUNDATION DEPTH (MIN.) DUE TO DAM FAILURE
 - R-00 BUILDING WITHIN INUNDATION AREA



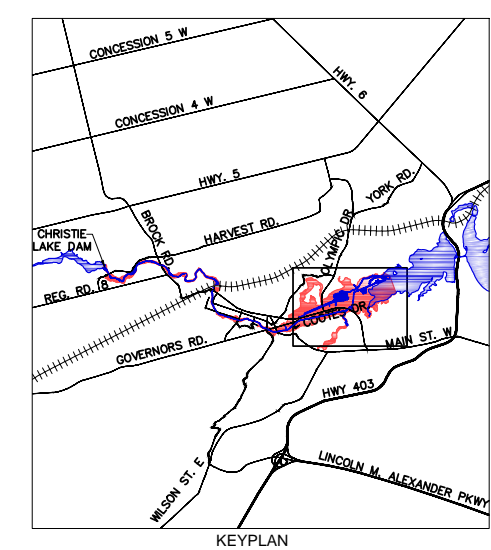
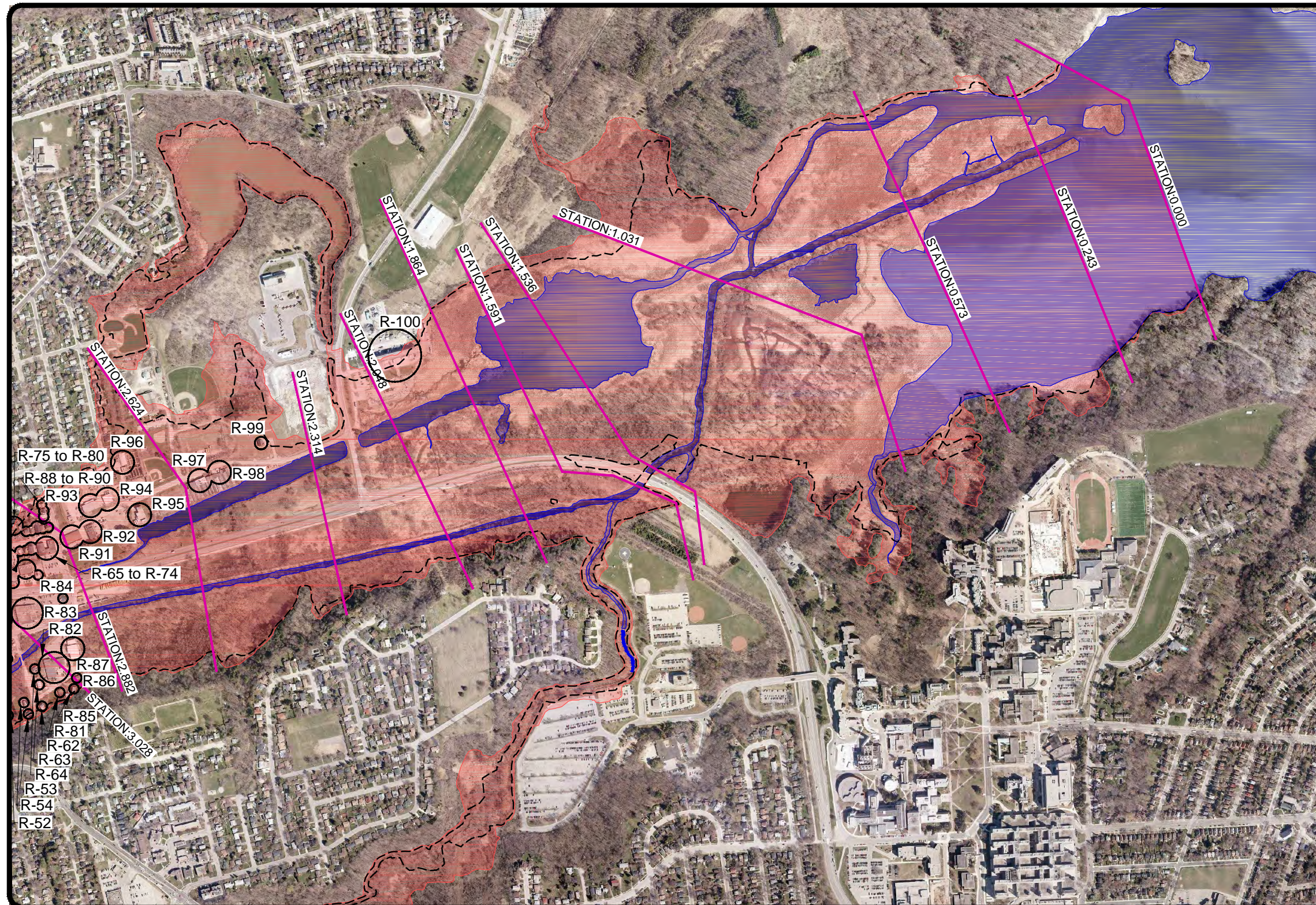
Project:		CHRISTIE LAKE DAM DAM SAFETY REVIEW	
Title:		SUNNY DAY CONDITION INUNDATION MAP	
Approved by:	S.K.	Date:	MAR. 18/2013
Project No.:	BRM00600601b		
Drawn by:	M.B.S.	Scale:	1:5000
Figure no.:	S-04 207		



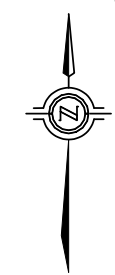
- LEGEND**
- LOCATION OF CROSS SECTION
 - NORMAL SUMMER WATER LEVEL
 - LIMIT OF INUNDATION DUE TO DAM FAILURE
 - 0.8m INUNDATION DEPTH (MIN.) DUE TO DAM FAILURE
 - R-00 BUILDING WITHIN INUNDATION AREA



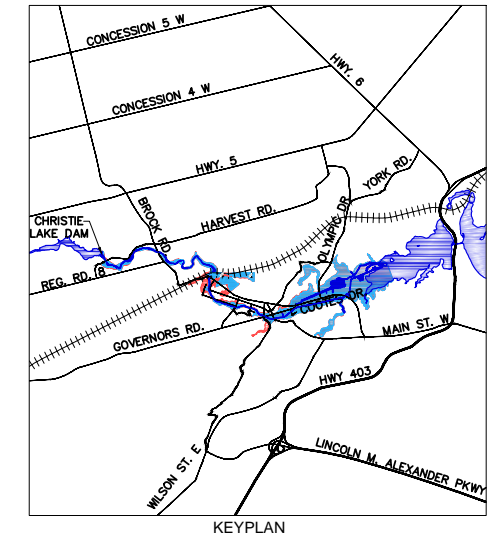
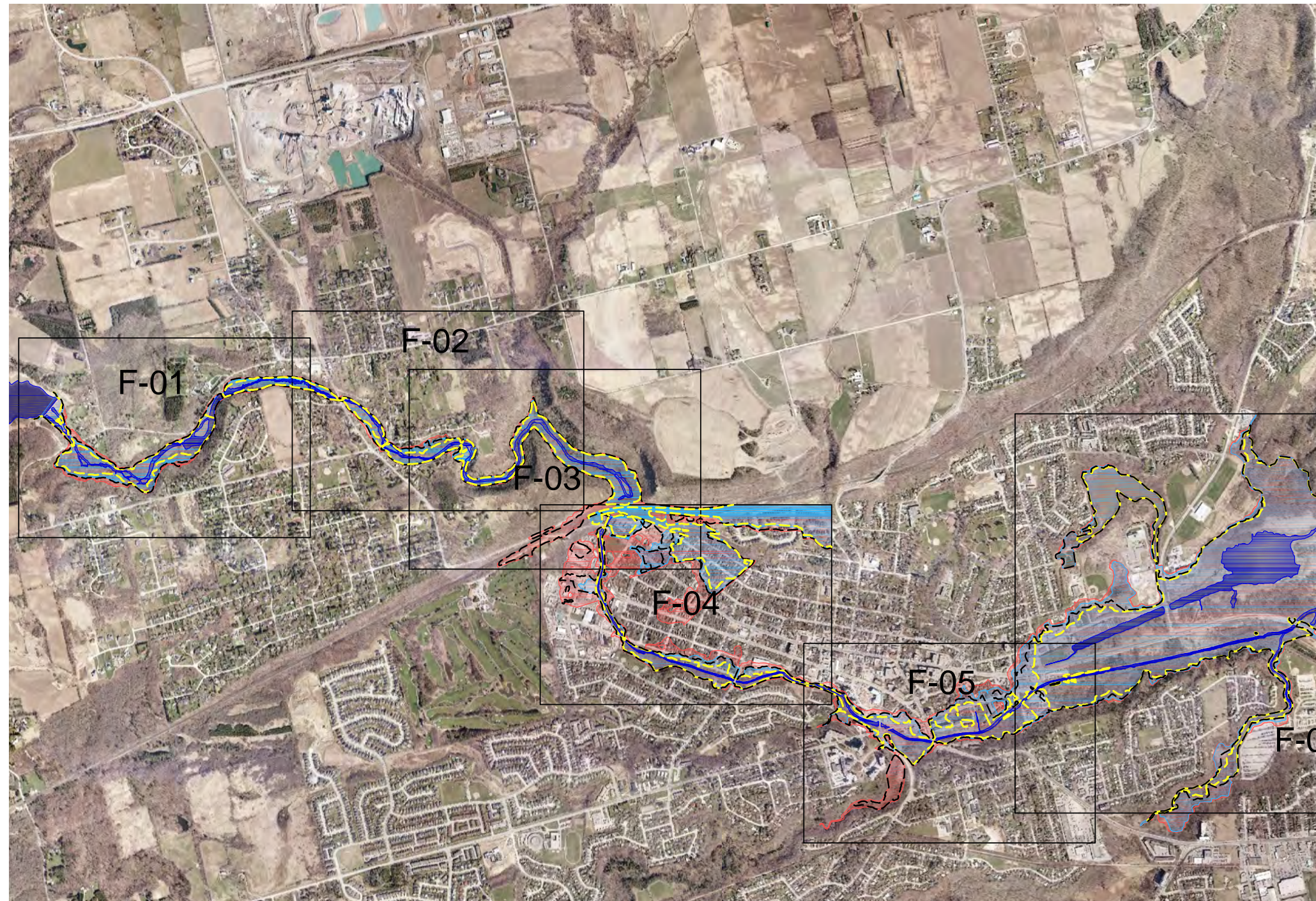
Project:		CHRISTIE LAKE DAM DAM SAFETY REVIEW	
Title:		SUNNY DAY CONDITION INUNDATION MAP	
Approved by:	S.K.	Date:	MAR. 18/2013
Project No.:	BRM00600601b		
Drawn by:	M.B.S.	Scale:	1:5000
Figure no.:	S-05 200		



LEGEND
 — LOCATION OF CROSS SECTION
 ■ NORMAL SUMMER WATER LEVEL
 ■ LIMIT OF INUNDATION DUE TO DAM FAILURE
 ■ 0.8m INUNDATION DEPTH (MIN.) DUE TO DAM FAILURE
 ● R-00 BUILDING WITHIN INUNDATION AREA



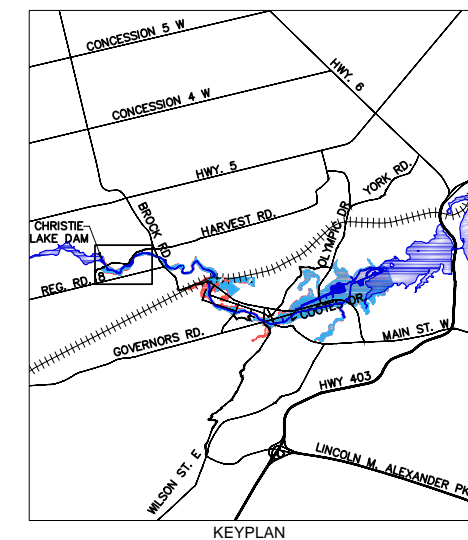
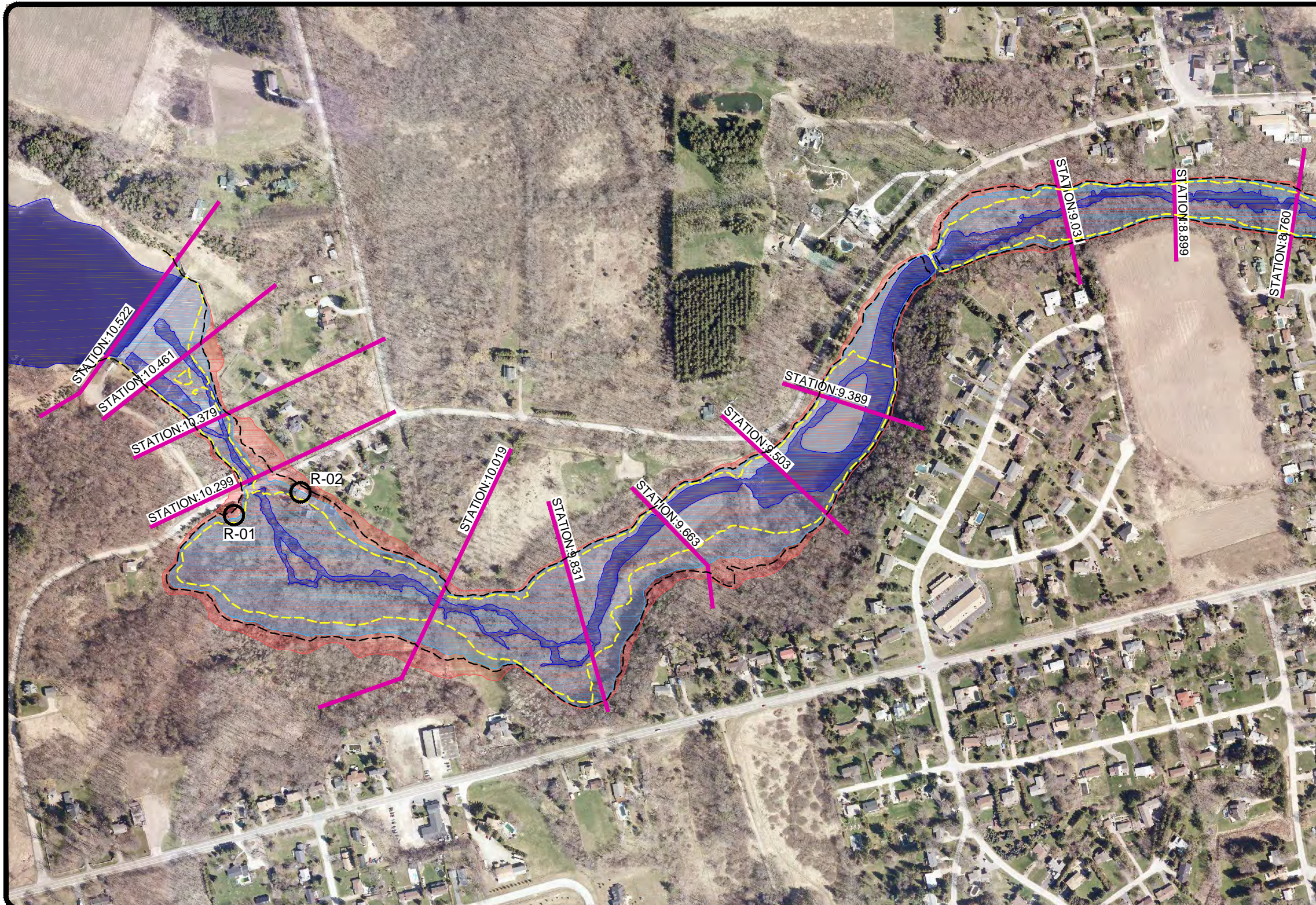
Project:			CHRISTIE LAKE DAM DAM SAFETY REVIEW
Title:			SUNNY DAY CONDITION INUNDATION MAP
Approved by:	S.K.	Date:	MAR. 18/2013
Project No.:	BRM00600601b		
Drawn by:	M.B.S.	Scale:	1:10000
Figure no.:	S-06 200		



- LEGEND**
- LOCATION OF CROSS SECTION
 - NORMAL SUMMER WATER LEVEL
 - LIMIT OF IDF INUNDATION
 - 0.8m IDF INUNDATION DEPTH (MIN.)
 - LIMIT OF INUNDATION DUE TO DAM FAILURE
 - 0.8m INUNDATION DEPTH (MIN.) DUE TO DAM FAILURE



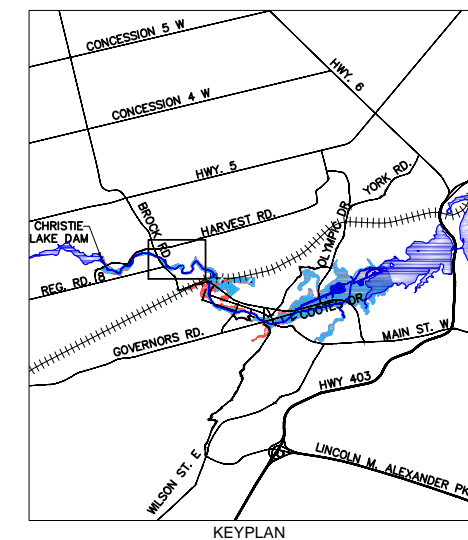
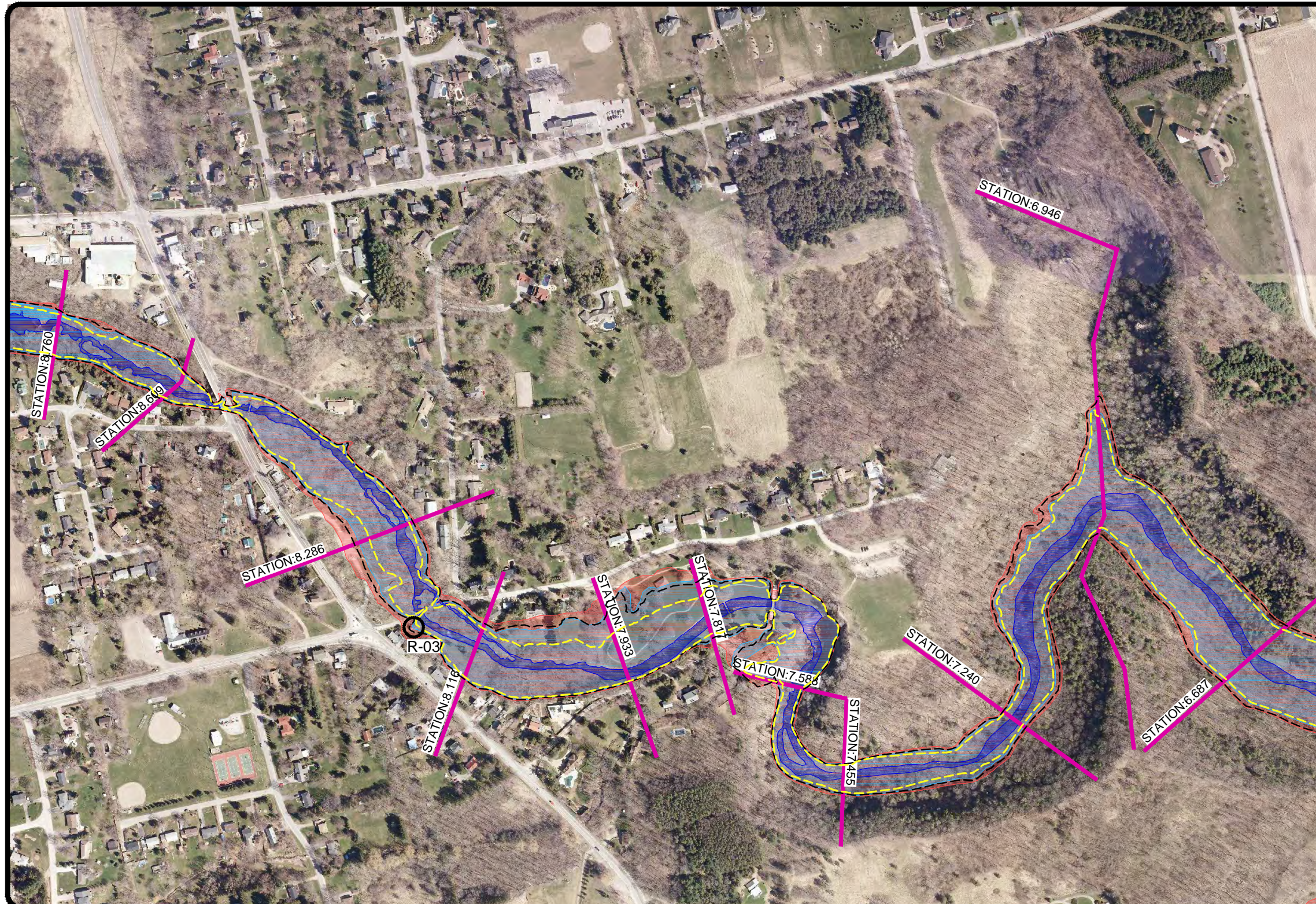
Project:		CHRISTIE LAKE DAM DAM SAFETY REVIEW	
Title:		INFLOW DESIGN FLOOD CONDITION (GENERAL PLAN)	
Approved by:	S.K.	Date:	MAR. 18/2013
Project No.:	BRM00600601b		
Drawn by:	M.B.S.	Scale:	1:25000
Figure no.:	F-00 240		



- LEGEND**
- LOCATION OF CROSS SECTION
 - NORMAL SUMMER WATER LEVEL
 - LIMIT OF IDF INUNDATION
 - 0.8m IDF INUNDATION DEPTH (MIN.)
 - LIMIT OF INUNDATION DUE TO DAM FAILURE
 - 0.8m INUNDATION DEPTH (MIN.) DUE TO DAM FAILURE
 - R-00 BUILDING WITHIN MIN. 0.8m DEEP INUNDATION AREA DUE TO DAM FAILURE



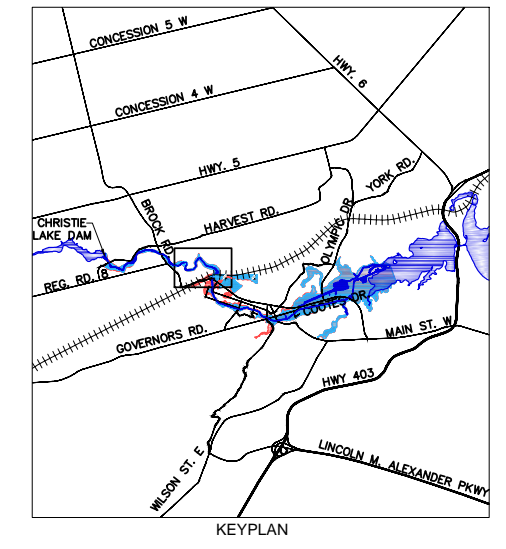
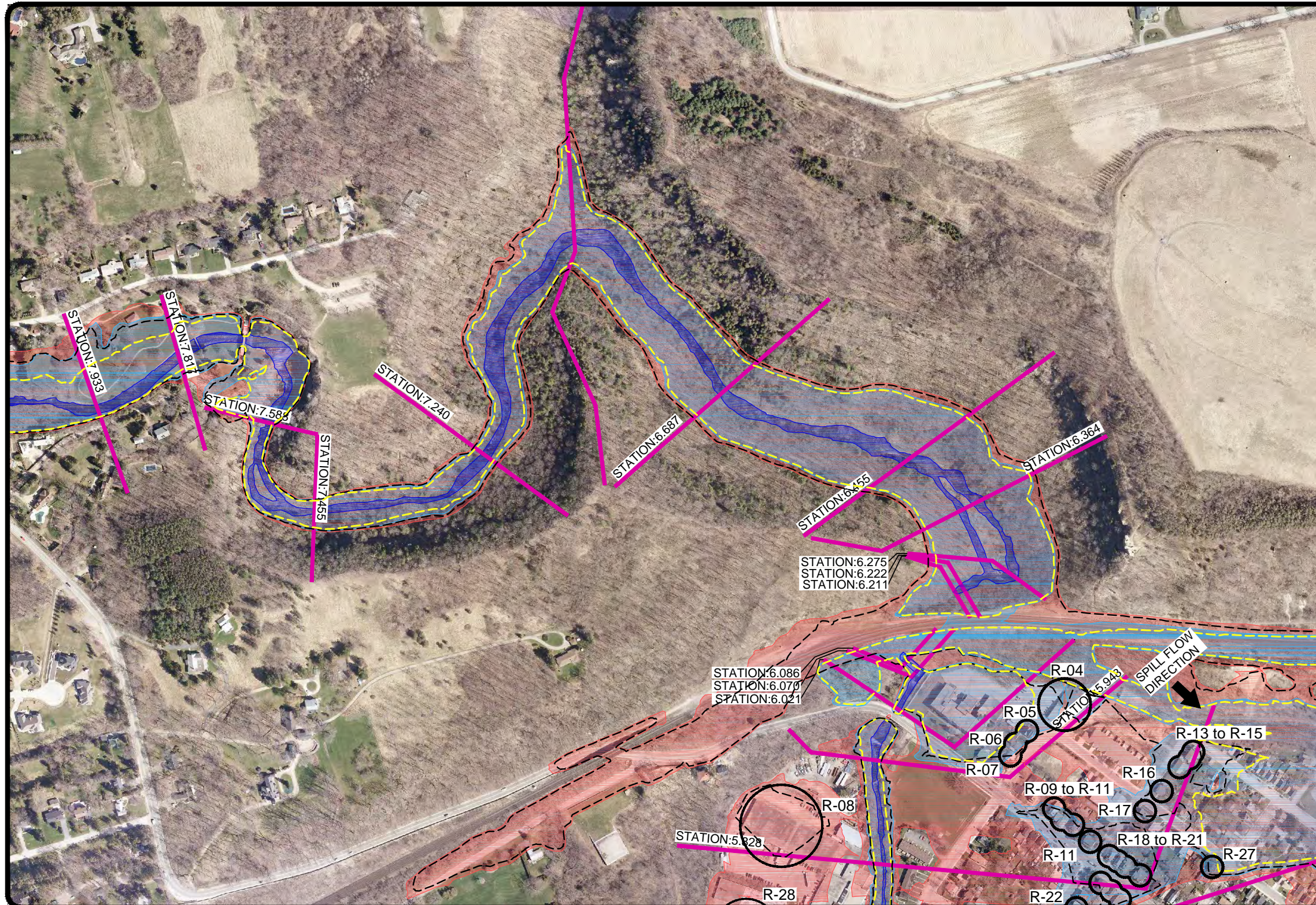
Project:			CHRISTIE LAKE DAM DAM SAFETY REVIEW		
Title:			INFLOW DESIGN FLOOD CONDITION INUNDATION MAP		
Approved by:	S.K.	Date:	MAR. 18/2013	Project No.:	BRM00600601b
Drawn by:	M.B.S.	Scale:	1:5000	Figure no.:	F-01



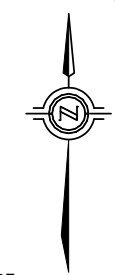
- LEGEND**
- LOCATION OF CROSS SECTION
 - NORMAL SUMMER WATER LEVEL
 - LIMIT OF IDF INUNDATION
 - 0.8m IDF INUNDATION DEPTH (MIN.)
 - LIMIT OF INUNDATION DUE TO DAM FAILURE
 - 0.8m INUNDATION DEPTH (MIN.) DUE TO DAM FAILURE
 - R-00 BUILDING WITHIN MIN. 0.8m DEEP INUNDATION AREA DUE TO DAM FAILURE



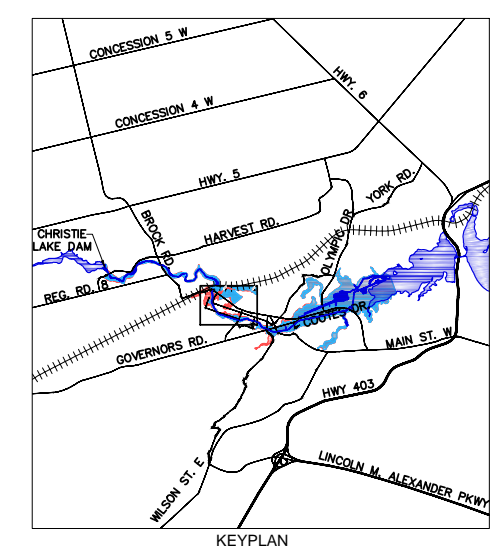
Project:			CHRISTIE LAKE DAM DAM SAFETY REVIEW		
Title:			INFLOW DESIGN FLOOD CONDITION INUNDATION MAP		
Approved by:	S.K.	Date:	MAR. 18/2013	Project No.:	BRM00600601b
Drawn by:	M.B.S.	Scale:	1:5000	Figure no.:	F-02 242



- LEGEND**
- LOCATION OF CROSS SECTION
 - NORMAL SUMMER WATER LEVEL
 - LIMIT OF IDF INUNDATION
 - 0.8m IDF INUNDATION DEPTH (MIN.)
 - LIMIT OF INUNDATION DUE TO DAM FAILURE
 - 0.8m INUNDATION DEPTH (MIN.) DUE TO DAM FAILURE
 - R-00 BUILDING WITHIN MIN. 0.8m DEEP INUNDATION AREA DUE TO DAM FAILURE



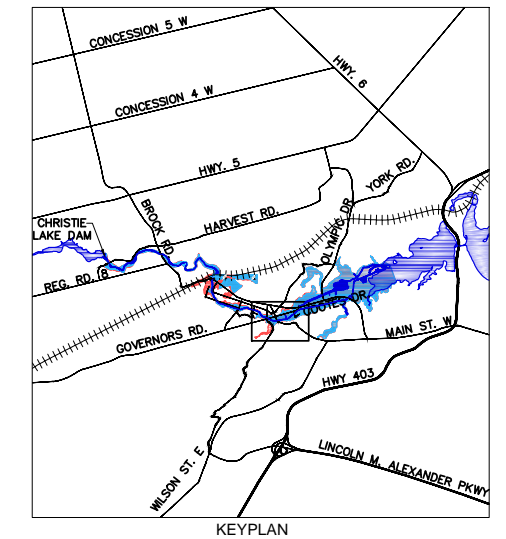
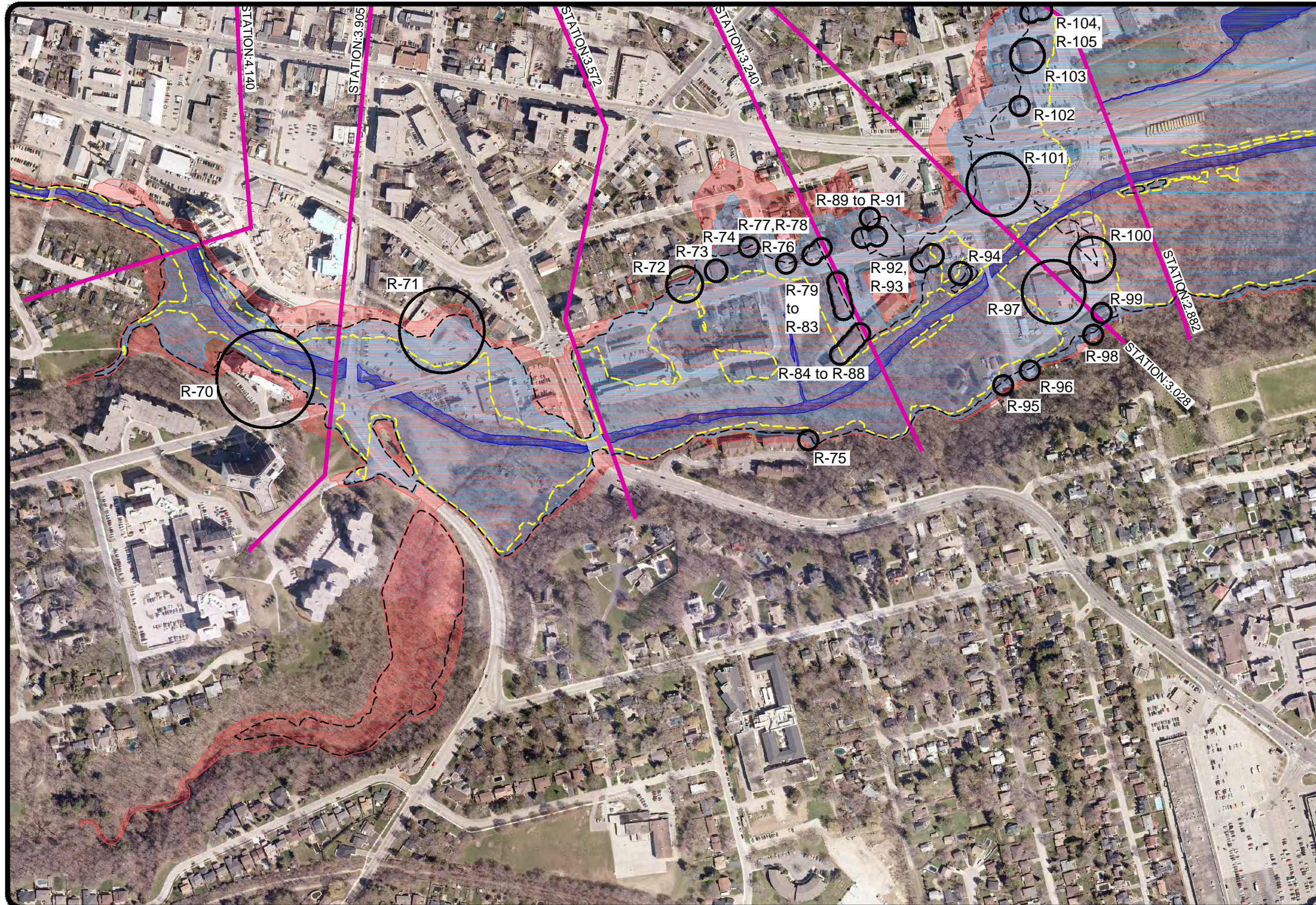
Project:		CHRISTIE LAKE DAM DAM SAFETY REVIEW	
Title:		INFLOW DESIGN FLOOD CONDITION INUNDATION MAP	
Approved by:	S.K.	Date:	MAR. 18/2013
Project No.:	BRM00600601b		
Drawn by:	M.B.S.	Scale:	1:5000
Figure no.:	F-03 243		



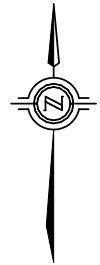
- LEGEND**
- LOCATION OF CROSS SECTION
 - NORMAL SUMMER WATER LEVEL
 - LIMIT OF IDF INUNDATION
 - 0.8m IDF INUNDATION DEPTH (MIN.)
 - LIMIT OF INUNDATION DUE TO DAM FAILURE
 - 0.8m INUNDATION DEPTH (MIN.) DUE TO DAM FAILURE
 - BUILDING WITHIN MIN. 0.8m DEEP INUNDATION AREA DUE TO DAM FAILURE



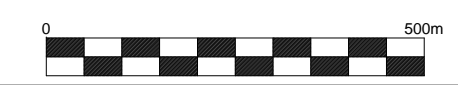
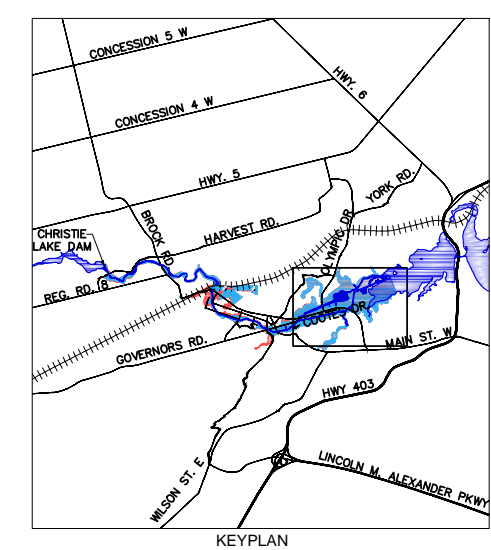
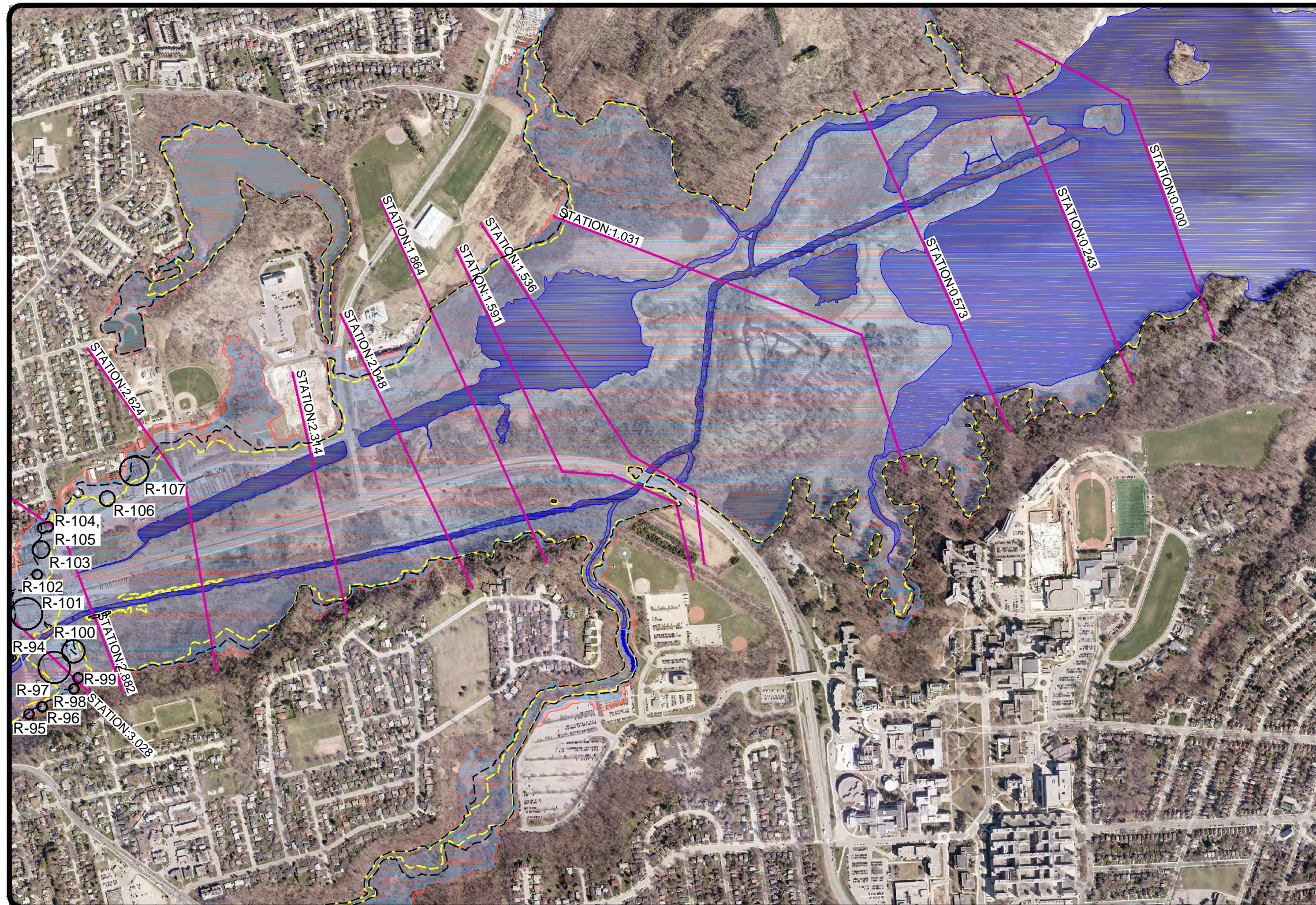
Project:		CHRISTIE LAKE DAM DAM SAFETY REVIEW	
Title:		INFLOW DESIGN FLOOD CONDITION INUNDATION MAP	
Approved by:	S.K.	Date:	MAR. 18/2013
Project No.:	BRM00600601b		
Drawn by:	M.B.S.	Scale:	1:5000
Figure no.:	F-04		



- LEGEND**
- LOCATION OF CROSS SECTION
 - NORMAL SUMMER WATER LEVEL
 - LIMIT OF IDF INUNDATION
 - 0.8m IDF INUNDATION DEPTH (MIN.)
 - LIMIT OF INUNDATION DUE TO DAM FAILURE
 - 0.8m INUNDATION DEPTH (MIN.) DUE TO DAM FAILURE
 - BUILDING WITHIN MIN. 0.8m DEEP INUNDATION AREA DUE TO DAM FAILURE



Project:			CHRISTIE LAKE DAM DAM SAFETY REVIEW		
Title:			INFLOW DESIGN FLOOD CONDITION INUNDATION MAP		
Approved by:	S.K.	Date:	MAR. 18/2013	Project No.:	BRM00600601b
Drawn by:	M.B.S.	Scale:	1:5000	Figure no.:	F-05 245



- LEGEND**
- LOCATION OF CROSS SECTION
 - NORMAL SUMMER WATER LEVEL
 - LIMIT OF IDF INUNDATION
 - 0.8m IDF INUNDATION DEPTH (MIN.)
 - LIMIT OF INUNDATION DUE TO DAM FAILURE
 - 0.8m INUNDATION DEPTH (MIN.) DUE TO DAM FAILURE
 - R-00 BUILDING WITHIN MIN. 0.8m DEEP INUNDATION AREA DUE TO DAM FAILURE



Project:		CHRISTIE LAKE DAM DAM SAFETY REVIEW	
Title:		INFLOW DESIGN FLOOD CONDITION INUNDATION MAP	
Approved by:	S.K.	Date:	MAR. 18/2013
Project No.:	BRM00600601b		
Drawn by:	M.B.S.	Scale:	1:10000
Figure no.:	F-06 246		

APPENDIX B.2

Valens Lake Dams

Emergency Response and Preparedness Plans

**EMERGENCY PREPAREDNESS PLAN
Valens Dam**

DISTRIBUTION			
Dam Operator	1 Copy		
HCA Administrative Office	1 Copy		
REVISIONS			
Revision	Date	Individual	Approved by
1	20/08/13	HCA	

TABLE OF CONTENTS

1	INTRODUCTION.....	1-1
1.1	PURPOSE.....	1-1
1.2	AUTHORITY	1-2
1.3	VALENS DAM.....	1-2
1.4	GENERAL SEASONAL OPERATING PROCEDURES.....	1-4
1.5	AVAILABLE GAUGES	1-4
1.6	ACCESS	1-5
1.7	HAZARD POTENTIAL	1-5
	1.7.1 UPSTREAM HAZARD	1-7
	1.7.2 DOWNSTREAM HAZARD.....	1-7
2	RESPONSIBILITIES.....	2-1
2.1	HCA STAFF RESPONSIBLE FOR DAM OPERATION.....	2-1
2.2	HCA DUTY OFFICER.....	2-1
2.3	FLOOD WARNING COORDINATOR	2-2
2.4	FLOOD PATROL OFFICERS	2-3
2.5	MUNICIPALITY	2-3
2.6	LOCAL RESPONSE COORDINATOR	2-4
3	EMERGENCY CONDITION IDENTIFICATION AND EVALUATION	3-1
3.1	FLOOD EVENT WITHOUT DAM FAILURE.....	3-8
3.2	POTENTIAL DAM FAILURE DEVELOPING	3-8
3.3	DAM FAILURE OR IMMINENT DAM FAILURE	3-12
3.4	CERTAIN EMERGENCIES NOT INVOLVING A DAM FAILURE OR FLOOD EVENT (MAJOR SPILLS AND EARTHQUAKES).....	3-14
4	NOTIFICATION PROCEDURES	4-1
4.1	EMERGENCY FLOOD EVENT OR A POTENTIAL, IMMINENT OR OCCURRING DAM FAILURE SITUATION.....	4-1
4.2	CITY OF HAMILTON EMERGENCY PLANNING, CITY OF HAMILTON EMERGENCY OPERATIONS CENTRE, AND HCA FLOOD CONTROL CENTRE	4-3
	4.2.1 CITY OF HAMILTON EMERGENCY PLANNING	4-3
	4.2.2 CITY OF HAMILTON EMERGENCY OPERATIONS CENTRE	4-4
	4.2.3 HCA FLOOD CONTROL CENTRE.....	4-5
4.3	EMERGENCY CONTACT NUMBERS	4-6
4.4	PROPERTIES IN THE POTENTIAL INUNDATION AREA.....	4-10
5	PREPAREDNESS ACTIONS	5-1
5.1	COMMUNICATIONS.....	5-1
5.2	DAM INSPECTION	5-1
5.3	DAM MAINTENANCE	5-1
5.4	ACCESS TO THE SITE	5-2
5.5	SECURITY AND PUBLIC WARNING SYSTEMS	5-2
5.6	POWER SOURCES.....	5-2
5.7	RESPONSE DURING DARKNESS.....	5-2
5.8	RESPONSE DURING ADVERSE WEATHER	5-2
5.9	EMERGENCY SUPPLIES AND RESOURCES.....	5-3
	5.9.1 SOURCES OF EQUIPMENT.....	5-3
	5.9.2 INTERNAL STOCKPILES.....	5-5
	5.9.3 EXTERNAL SOURCE MATERIALS	5-6
6	INUNDATION MAPS	6-1

7 IMPLEMENTATION.....7-2

7.1 LOCAL COORDINATION7-2

7.2 STAFF TRAINING OF EPP7-2

7.3 UPDATING AND REVIEWING THE EPP7-3

LIST OF FIGURES

Figure 1.1. Spencer Creek Watershed1-3

Figure 1.2. Valens Dam Location Plan1-6

Figure 4.1. Location of properties within the potential inundation area for a dam break during an Inflow Design Flood event.4-12

LIST OF APPENDICES

- APPENDIX A - DRAWINGS & DAM DATA SHEET
- APPENDIX B - INUNDATION MAPS
- APPENDIX C - REFERENCE PHOTOGRAPHS

1 Introduction

Valens Dam is owned and operated by the Hamilton Conservation Authority. The dam is located in the Valens Conservation Area, at the headwaters of the Spencer Creek watershed, and is situated on Lot 24, Concession IX in Beverley Township, City of Hamilton.

As part of an overall dam safety program that is being implemented by the Hamilton Conservation Authority (HCA) and Ministry of Natural Resources (MNR), this Emergency Preparedness Plan (EPP) is prepared for Valens Dam on the basis of the results of the various analyses performed and the requirements of the Canadian Dam Association (CDA) Dam Safety Guidelines (2007). From time to time, this plan may be updated. Details of the various revisions to the plan and the holders of this document are contained in the inside cover of the document.

This document is site specific for Valens Dam and makes reference to the HCA's Flood Emergency Manual (FEM), which is the master emergency response document of the Conservation Authority.

1.1 Purpose

According to the requirements of the CDA Dam Safety Guidelines (2007):

“In the EPP, the dam owner describes the hazards, the associated notifications to be issued, and in general terms the actions expected of other responders.”

For the normal day to day operation of the dam, the dam operator would refer to the Valens Dam - Operation, Maintenance, Surveillance and Safety (OMSS) Manual (exp, 2013).

A comprehensive EPP is necessary to ensure that all parties responsible for water control along the watershed are involved in an action plan to ensure the safety of the public in the event of a dam emergency.

The purpose of the EPP report is to describe the procedures that should be followed and the actions that should be taken when an emergency situation is identified at the Valens Dam site.

Specifically, this plan is intended to allow the dam operator (or other designated staff) to clearly identify what constitutes an emergency situation (Section 3) and details:

- HCA staff responsibilities for notification in the event of an emergency (Section 4);
- Any additional responsibilities of staff for warning or evacuating people within the immediate vicinity of the dam (Section 4);

- Locations of equipment suppliers and materials available to staff to assist in mitigating the effects of an emergency (Section 5); and
- Drawings showing the characteristics of the dam and the inundation maps (Appendix A and B respectively).

Characteristics of the dam and surrounding area, details of access to the site and details of the potential for flooding in the event of a dam failure are described in this section.

1.2 Authority

Under the Emergency Management Act, each Ministry must develop a Provincial Emergency Response Plan (ERP) for their assigned area of special responsibility. MNR has been designated as the lead for flood, fire, drought, dam failures, oil and gas, and landslides/subsidence/unstable slopes.

Each MNR district office has its own local ERP that ties into the MNR Provincial Plan.

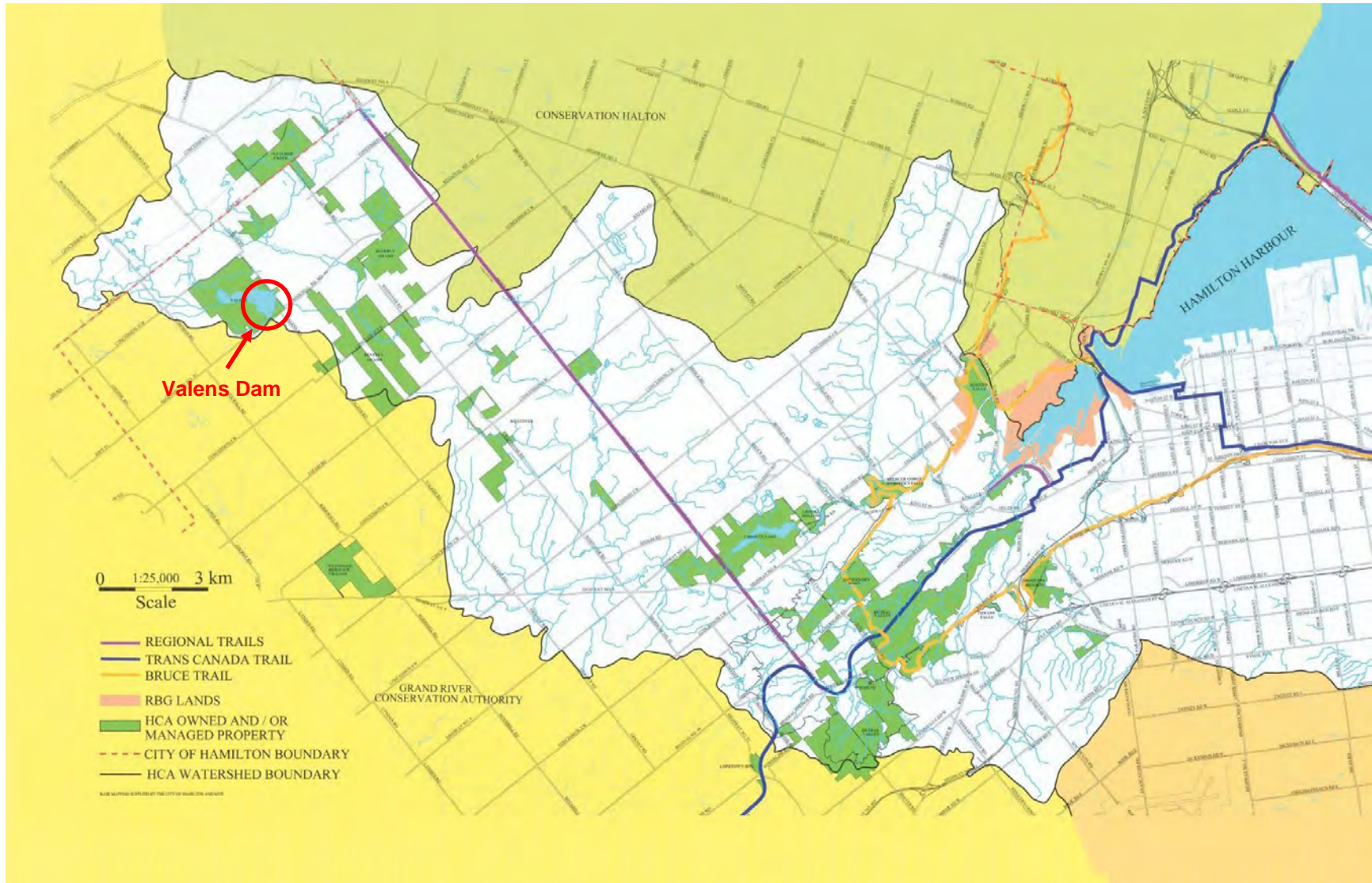
This Emergency Preparedness Plan for Valens Dam is developed in accordance with the CDA Dam Safety Guidelines (2007) and will form part of the HCA's Flood Emergency Manual. It is the responsibility of the Conservation Authority to operate a flood forecasting and warning system.

1.3 Valens Dam

The dam is located on Lot 24, Concession IX in Beverley Township, City of Hamilton, on Spencer Creek. The coordinates of the dam are 43° 22' 58" N latitude and 80° 8' 2" W longitude, or 4803693 Northing and 580159 Easting UTM Zone 17.

The dam is an earth embankment with a concrete control structure that is 121.9m long, 6.3m high, with a crest width of approximately 4.5m. The concrete control structure consists of a drop inlet structure controlled by four 2.9m long stop log bays and a low flow valve. There are nine 76mm high, 254mm wide stop logs in each bay. The low flow valve diameter is 0.36m.

Figure 1.1. Spencer Creek Watershed



This page intentionally left blank.

Outflow from Valens Dam flows into Beverly Swamp, through which Spencer Creek flows. Spencer Creek ultimately discharges into Lake Ontario through Hamilton Harbour.

The Spencer Creek drainage area that is controlled by the Valens Dam (Figure 1.1) is approximately 12.4 km².

The drawings of the dam are provided in Appendix A. Appendix A also includes the Valens Dam Data Sheet which summarizes the main characteristics of the dam, such as storage volumes at key reservoir levels and key elevations.

1.4 General Seasonal Operating Procedures

Under normal conditions, significant changes to the stop log, and low flow valve settings are required approximately 2 times a year, once during the Spring (when all 8 stoplogs are placed in each bay to achieve the summer target water level) and once during the Fall (when all stoplogs are removed from each bay and the low flow valve is opened to achieve the winter target water level). In addition, water levels are routinely adjusted during and after snowmelt and rainfall events by operating the low flow valve. The purpose of the operations is to maintain the reservoir water levels at or near the target water level for the different seasons. A year can be divided into 'Fall', 'Winter', 'Spring' and 'Summer' seasons. Each period has different target water levels and hence the dam needs to be operated accordingly.

The target water levels at the Valens Dam are as follows:

Table 1-1: Target Operating Water Levels by Season

Season	Date	Target Water Level (Gauge Reading) m GSC
Summer	June 1 – Sept 15	275.25
Fall-Winter	Nov 15 – March 15	273.72

Please refer to Section 6 of the Valens Dam - Operation, Maintenance, Surveillance and Safety (OMSS) Manual (exp, 2013) for further details regarding the seasonal operating procedures.

1.5 Available Gauges

A staff gauge is installed at Valens Dam, which is mounted on the east wall of the concrete control structure on the upstream side. The gauge is correlated to its Canadian Geodetic Datum elevation.

In addition to the staff gauge, there is an automatic water level gauge with data logger located on the upstream side of the dam at the north end.

Please refer to Section 10 of the Valens Dam - Operation, Maintenance, Surveillance and Safety (OMSS) Manual (exp, 2013) for further details regarding the available gauges.

1.6 Access

Valens Dam can be accessed via Regional Road 97. The north side can be accessed through private property from Valens Road and the south side through Valens Conservation Area. The travel time is approximately a 30 minute drive from the HCA office (838 Mineral Spring Road, Ancaster, Ontario).

The location plan of the Valens Dam is shown in Figure 1.2.

1.7 Hazard Potential

A dam break analysis was previously completed ("Dam Break Analysis – Valens Dam (exp, 2012)). Under the Lakes and Rivers Improvement Act (LRIA) 2011 Technical Bulletin, Classification and Inflow Design Flood Criteria, the Hazard Potential Classification (HPC) of the Valens Dam was determined as VERY HIGH and the inflow design flood (IDF) was selected to be the flood 2/3 between the 1:1000 year flood and the PMF. The HPC was selected as VERY HIGH due to the potential loss of life between 11 to 100 persons as a result of a dam failure under both sunny day (normal) and inflow design flood conditions.

There are three primary types of hazards that can occur at the dam:

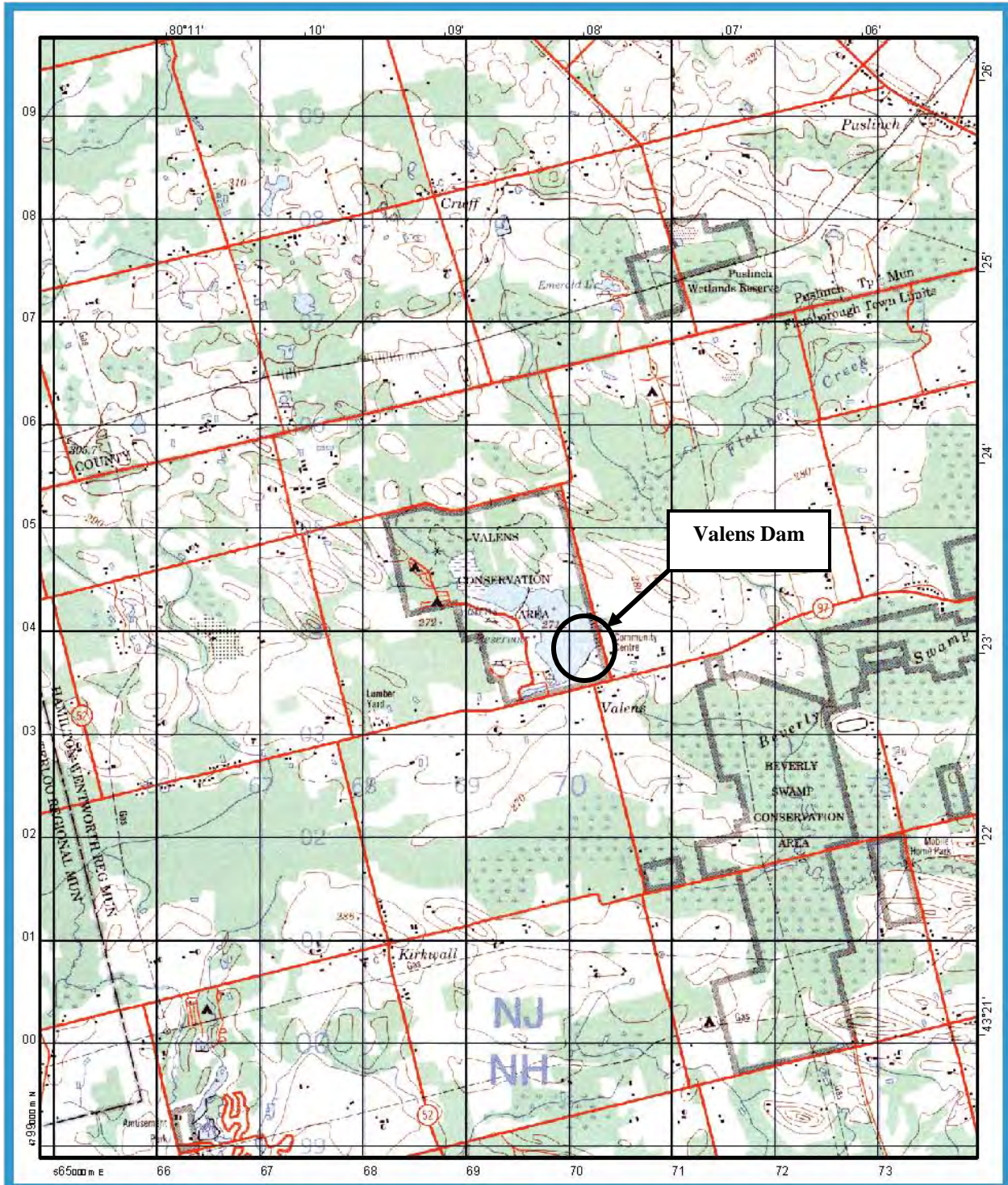
1. Non-Dam Failure During An Extreme Flood Event
2. Dam Failure During A Non-Flood Event
3. Dam Failure During A Flood Event

Non-dam failure during an extreme flood event is the most common type of hazard that would generally occur at this type of structure.

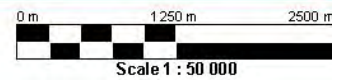
Failure during a non-flood event is also known as a dry weather/sunny day break. Because there is no warning with this type of failure, the potential hazard for loss of life is the highest.

A dam failure during a flood event will produce maximum downstream flood elevations thereby increasing the potential for loss of life and property damage.

Figure 1.2. Valens Dam Location Plan



Produced under licences granted by Her Majesty the Queen in right of Canada, represented by the Department of Natural Resources, and by SoftMap Technologies Inc.



1.7.1 Upstream Hazard

The upstream hazard would be related to a non-dam failure during an extreme flood event and a dam failure during a non-flood event.

The non-dam failure during an extreme flood event could cause property damage to the surrounding conservation area and campground from the reservoir overflow. The flood elevations along the shorelines of the reservoir are as follows in Table 1-2 (as per Valens Dam – Dam Break Analysis, exp 2012):

Table 1-2: Reservoir flood elevations for a non-dam failure during an extreme flood event

Flood Event	Flood Elevation (m)
2/3 between 1000-yr Flood and PMF	276.35
PMF	276.65

A dam failure during a non-flood event will release the minimum flood wave at the dam and may pose a danger to those individuals that would be in close proximity of the dam. These parties may include boaters and/or fishermen immediately upstream of the dam and HCA staff.

1.7.2 Downstream Hazard

The downstream hazard can be related to all three types of dam failure.

The non-dam failure during an extreme flood event would require the release of high flows through the control structure that could cause downstream environmental and property damage. There is also potential for loss of life.

A dam failure during a non-flood event will release a minimal flood wave from the dam site and will pose a danger to those individuals that would be in close proximity of the dam. These persons may include HCA staff. There may be some downstream environmental and property damages.

Similarly, a dam failure during a flood event would produce the largest flood wave release from the dam site and could pose a threat to life for those individuals that would be in close proximity of the dam. Downstream environmental and property damages would be expected.

2 Responsibilities

2.1 HCA Staff Responsible for Dam Operation

HCA staff are responsible for:

- Ensuring that the equipment for communication, etc. are well maintained and in working condition, and supplies and materials needed in an emergency situation are sufficient and put in the appropriate place or are readily available from local suppliers;
- Ensuring that access to the site is maintained;
- Ensuring the safe operation of the dam;
- Performing routine visual and special inspections of the dam for potential problems (e.g. dam, concrete conditions, inlet drop structure and low flow valve conditions, foundations, seepage and sign of failure, etc.). Please refer to Section 8 of the Valens Dam - Operation, Maintenance, Surveillance and Safety (OMSS) Manual (exp, 2013) for further details;
- Reporting to the Manager of Water Resources Engineering of any dam deficiencies whenever they are observed;
- Identifying emergency conditions;
- Notifying the Flood Warning Coordinator, or alternate, for any emergency condition that is occurring or has occurred;
- Taking appropriate actions to mitigate the damages resulting from such emergency conditions, under the direction of the Flood Warning Coordinator, or alternate; and,
- Notifying anyone immediately downstream of the dam that may be in immediate danger.

2.2 HCA Duty Officer

The HCA currently operates a Duty Officer system to ensure that, at all times, one member of the Duty Officer's Team are available and alert to potential problems that may arise in the watershed. The Duty Officer is an HCA staff member available for immediate contact in the event of an emergency. The Duty Officer is responsible for contacting the appropriate personnel in the event of an existing or impending major emergency situation, including the Flood Warning Coordinator, or alternate.

2.3 Flood Warning Coordinator

The Flood Warning Coordinator, or alternate, is an HCA staff member who is responsible for flood warning and dam operation. Presently, the Flood Warning Coordinator duties are fulfilled by the Manager of Water Resources Engineering. The alternate Flood Warning Coordinator is to be the Water Resources Engineer. The Flood Warning Coordinator will be assisted by HCA Flood Patrol Officers

During flooding and flood emergencies, the Flood Warning Coordinator, or alternate, is responsible for:

- Allocate HCA resources;
- Monitor watershed and weather conditions, and operate a flood forecasting system in order to provide warning of anticipated or actual flood conditions;
- Issue Watershed Conditions Statements, Flood Watch and Flood Warning bulletins to advise of potential flooding, to the following:
 - City of Hamilton staff, including the emergency preparedness coordinator(s)
 - HCA staff
 - Adjacent Conservation Authorities
 - Surface Water Monitoring Centre of the Ministry of Natural Resources
 - Local Response Coordinators at the District Offices of the Ministry of Natural Resources
 - Regional police
 - School Boards
 - News Media
- Operate HCA dams to reduce the effects of flooding;
- Communicate with the City of Hamilton to assess the need to begin the emergency response process and assembly of an Emergency Operations Centre (EOC), including a HCA Flood Control Centre;
- During a declared flood emergency (as declared by the City of Hamilton):
 - Maintain communications with the City of Hamilton, City of Hamilton EOC, and the Surface Water Monitoring Centre of the Ministry of Natural Resources. This may include updated flood bulletins, additional flooding and weather information as well as advice to prevent or reduce the effects of flooding.

- Set up a 24 hour operational Flood Control Centre at the City of Hamilton EOC. Refer to Section 4.2 for additional details.
- Provide technical information and advice for request by the City of Hamilton for provincial assistance through the Local Response Coordinator of the Ministry of Natural Resources, when requested by the City of Hamilton if actions are insufficient to meet a flood emergency.

2.4 Flood Patrol Officers

During an emergency situation, HCA staff members having a detailed knowledge of certain watercourses will be assigned to specific areas to assess situations and will report problems or possible problem areas to the base of operation.

2.5 Municipality

The City of Hamilton has the primary responsibility for response to flooding and flood emergencies, and also for the welfare of residents and protection of property. Upon receiving a Flood Watch or Flood Warning, the City of Hamilton shall:

- Notify appropriate municipal officials, departments and agencies in accordance with their municipal emergency plan;
- Determine the appropriate response and if warranted, deploy municipal resources;
- If required, declare a flood emergency and implement their Emergency Procedures Plan. The decision to assemble the Municipal Emergency Control Group and Municipal EOC is determined by the City of Hamilton emergency preparedness staff, and will be based upon the level and degree of flood threat which may be affecting the municipality;
- Request provincial assistance through the Local Response Coordinator of the Ministry of Natural Resources, if municipal resources are inadequate; and,
- Maintain liaison with the HCA Flood Coordinator.

2.6 Local Response Coordinator

The Local Response Coordinator is the District Manager (Guelph) of the Ministry of Natural Resources. The local Response Coordinator is responsible for:

- Alerting HCA regarding general provincial alerts;
- Alerting key MNR personnel and other Government Ministries which may be required for assistance;
- Assessing the flood situation, in conjunction with HCA and adjacent Conservation Authorities;
- Responding to a request by the City of Hamilton for provincial assistance, through the Provincial Flood Contingency Plan, should the total resources of the City of Hamilton be committed or inadequate and the municipality has declared an emergency situation. The Minister of Natural Resources is responsible for declaring a Provincial flood emergency. Declaration of a Provincial flood emergency may include the assembly of a Provincial Emergency Control Group and Provincial EOC; and,
- Coordinating the delivery of the provincial response in a declared emergency.

3 Emergency Condition Identification and Evaluation

Potential downstream consequences of a Valens Dam failure could include:

- Potential loss of life at the residences located immediately downstream of the dam;
- Damage to Regional Road 97 and the respective culverts;
- Environmental damage along Spencer Creek downstream of the dam;
- Residential and property damage downstream of dam; and
- Flooding of agricultural and park lands.

Potential dam emergency conditions that are subject to the Valens Dam EPP are summarized in the following sections. Potential dam emergency conditions have been categorized by the following Response Levels:

- Flood event without dam failure;
- Potential dam failure developing;
- Dam failure or imminent dam failure; and,
- Certain emergencies not involving a dam failure or flood event (Major Spills and Earthquakes only)

For additional emergencies not involving a dam failure or flood event, the HCA FEM contains detailed procedures to be followed by various parties. Additional emergencies not involving a dam failure or flood event include:

- Major Emergency
 - Major medical emergency
 - Major accident (including boating)
 - Drowning
 - Fires
 - Major landslide or rock fall
- Dam-Related Problem
 - Power outage / blackout
 - Creek concerns
 - Security problems
 - Park gate problems
 - Vandalism
 - Theft
 - Vicious animals

The Emergency Action Table provides a listing of potential dam emergency conditions, as well as dam operational actions, emergency coordination actions, notification procedures, and data to monitor / record. This is not intended to be an exhaustive list and capture all potential events; it is intended to be a guide.

Dam operational actions may include preventative actions and inspections. Preventative actions and inspections are to be determined and ordered by the Flood Warning Coordinator or alternate, who will then communicate required actions at the dam to the dam operator or other associated HCA staff. Decisions should be based on current dam conditions, current and forecasted weather, watercourse and flood conditions, as well as available inundation mapping of dam break scenarios for the dam and flood plain mapping for Spencer Creek.

Every emergency situation is unique or has unique features, just as every dam has unique characteristics and conditions. Therefore, there are no preventive actions that can be prescribed for all cases. However, the following sections provide some examples of actions that may help alleviate certain failure scenarios. These examples are generic in nature and are by no means all-inclusive. The objectives of preventive actions at the dam include, but are not limited to, one or more of the following:

- Preventing emergency conditions from developing, if possible, or warning of the development of emergency situations;
- Facilitating emergency measures at the dam to limit impacts in an emergency situation; and,
- Minimizing the extent of damage resulting from any emergency situation that does develop.

Supplemental to the preventative actions at the dam, additional emergency actions are provided which may include:

- Downstream flood monitoring;
- Assessing the potential impacts of low flow valve and stop log setting changes on downstream flooding conditions;
- Evaluating the potential flooding impacts of a dam break;
- Restricting access to the dam; and,
- Evacuating HCA staff from potential inundation areas.

Notification procedures are detailed in Section 4. Expected notifications are provided, including internal and external communications. Notifications include flood bulletins, and providing technical information and advice to the City and various agencies regarding watershed conditions, flooding conditions and potential dam break impacts. Accurate collection and distribution of information is critical during an emergency event.

Documentation of monitored data (reports or journal entries) should include the following information:

- Current water levels;
- Rate of water level change;
- Actions that have been taken;
- Who has been notified;
- Estimated dam discharge;
- Dam conditions;
- Date, time and weather conditions;
- Author of the report; and,
- Photographic record.

This Valens Dam EPP is to be carried out in conjunction with the HCA Flood Emergency Manual (FEM). The HCA FEM contains detailed procedures to be followed by various parties.

This page intentionally left blank.

Response Level	Potential Dam Emergency Conditions	Dam Operational Actions	Additional Emergency Actions	Notification	Data to Monitor / Record
Flood Event Without Dam Failure	Water level exceeds 275.25 m (target summer water level) + Water Level steadily rising	<ul style="list-style-type: none"> Under the direction of HCA Water Resources Engineering staff, dam operator to gradually open low flow valve to fully open, as required to lower water levels in the reservoir to 275.25 m. {Procedure as per Section 6.3 of the OMSS Manual (exp, 2013)}. 	<ul style="list-style-type: none"> HCA Water Resources Engineering staff to monitor downstream areas for early indications of channel capacity exceedences or flooding, using data collected by the HCA gauge station network and site observations (as required). 	<ul style="list-style-type: none"> Dam operator to notify HCA Water Resources Eng. staff - updated dam low flow valve settings. If required, Flood Warning Coordinator, or alternate, to issue flood bulletins (Watershed Conditions Statement, Flood Watch or Flood Warning, as required). Flood bulletins are based on current and forecasted weather, watercourse and flood conditions, as well as available flood plain mapping for Spencer Creek. Flood Warning Coordinator, or alternate, to notify the City of Hamilton, police, Local Response Coordinator of the MNR and all other agencies required, as necessary. Flood Warning Coordinator, or alternate, to notify the appropriate HCA staff, including the HCA Chief Administrative Officer and HCA Director of Planning and Engineering. 	<p>DAILY</p> <ul style="list-style-type: none"> Water discharge, headwater, tailwater elevations and rate of change Weather conditions
	Water level is 276.16 m (Maximum Design Flood Level for the reservoir) + Water Level rising + Low Flow Valve is fully open	<ul style="list-style-type: none"> Under the direction of the HCA Flood Warning Coordinator, or alternate, dam operator to remove some or all stoplogs, to lower water levels in the reservoir towards 275.25 m. The HCA Flood Warning Coordinator or alternate will evaluate the potential downstream flooding impacts of removing any stoplogs, as well as whether it is potentially viable and safe to remove only some of the stoplogs. To remove all of the stoplogs quickly, a lifting device (front-end loader, etc) can be used to lift the chains connected to the steel stanchions that hold the stoplogs. Procedure as per Section 6.3 of the OMSS Manual (exp, 2013)}. 	<ul style="list-style-type: none"> Flood Warning Coordinator, or alternate, and HCA Water Resources Engineering staff to review the potential impacts of the removal of the stop logs on downstream areas. HCA Water Resources Engineering staff to monitor downstream areas for indications of channel capacity exceedences or flooding, using data collected by the HCA gauge station network and site observations (as required). 	<ul style="list-style-type: none"> Dam operator to notify the Flood Warning Coordinator, or alternate - updated dam stop log settings. Flood Warning Coordinator, or alternate, to advise the City of Hamilton to install safety barricades on the Township roads that may be flooded. Flood Warning Coordinator, or alternate, to issue flood bulletins (Watershed Conditions Statement, Flood Watch or Flood Warning, as required). Flood bulletins are based on current and forecasted weather, watercourse and flood conditions, as well as available flood plain mapping for Spencer Creek. Flood Warning Coordinator, or alternate, to notify the appropriate HCA staff, the HCA Flood Control Centre (if opened), the HCA Chief Administrative Officer, and HCA Director of Planning and Engineering. 	<p>HOURLY</p> <ul style="list-style-type: none"> Water discharge, headwater, tailwater elevations and rate of change Downstream flooding conditions (as required) Weather conditions Dam conditions Photographs
Potential Dam Failure Developing	Dam overtopping or dam break due to high water levels: Water level exceeds, or is forecasted to exceed (NOTE 1), 276.16 m + Water Level rising or is forecasted to continue to rise + All stop logs are out and Low Flow Valve is fully open	<ul style="list-style-type: none"> Dam operator to complete inspections of the dam on a daily interval, or at a smaller interval as directed by the Flood Warning Coordinator, or alternate. Focus of the inspections should be on changes in conditions of the embankment and drop inlet control structure arising due to the high reservoir water levels. Procedure as per Section 8 of the OMSS Manual (exp, 2013), unless otherwise directed by the Flood Warning Coordinator. Under the direction of the HCA Flood Warning Coordinator or alternate, dam operator to complete preventative actions. 	<ul style="list-style-type: none"> HCA Water Resources Engineering staff to monitor downstream areas for indications of channel capacity exceedences or flooding, using data collected by the HCA gauge station network and site observations (as required). Flood Warning Coordinator, or alternate, and HCA Water Resources Engineering staff to review the potential flooding impacts of a dam break. Flood Warning Coordinator or alternate to provide advisory role regarding evacuation procedures and required times for evacuation to appropriate City of Hamilton staff (Emergency Management staff and 	<ul style="list-style-type: none"> Dam operator to notify the Flood Warning Coordinator, or alternate - updated dam conditions. Flood Warning Coordinator, or alternate, to advise the City of Hamilton to install safety barricades on the Township roads that may be flooded. Flood Warning Coordinator, or alternate, to issue flood bulletin updates (Watershed Conditions Statement, Flood Watch or Flood Warning, as required). Flood bulletins are based on current and forecasted weather, watercourse and flood conditions. Flood bulletins are also based on available flood plain mapping for Spencer Creek, as well as inundation mapping of potential dam break scenarios. Flood Warning Coordinator, or alternate, to notify the City of Hamilton, police, Local Response Coordinator of the MNR and all other agencies required, as necessary regarding potential 	<p>HOURLY or DAILY</p> <ul style="list-style-type: none"> Water discharge, headwater, tailwater elevations and rate of change Weather conditions Dam conditions Photographs Downstream flooding conditions (as required)

			Emergency Control Group members), regional / OPP police.	dam failure conditions and potential impacts of dam failure.	
<p>Dam break due to dam embankment or control structure conditions, such as:</p> <ul style="list-style-type: none"> erosion cracking movement settlement riprap rock protection displacement increased seepage through the embankment 	<ul style="list-style-type: none"> Dam operator to complete inspections of the dam on a daily interval, or at a smaller interval as directed by the Flood Warning Coordinator, or alternate. Focus of the inspections should be on changes in conditions of the embankment and drop inlet control structure. Procedure as per Section 8 of the OMSS Manual (exp, 2013), unless otherwise directed by the Flood Warning Coordinator. Under the direction of the Flood Warning Coordinator, or alternate, dam operator to gradually open low flow valve and remove stop logs to maximum safe flow capacity, to lower reservoir water levels {Procedure as per Section 6.3 of the OMSS Manual (exp, 2013)}. Under the direction of the HCA Flood Warning Coordinator or alternate, dam operator to complete additional preventative actions. 	<ul style="list-style-type: none"> Flood Warning Coordinator, or alternate, and HCA Water Resources Engineering staff to review the potential impacts on downstream areas due to increased discharge from the dam as a result of changes to the dam low flow valve and stop log settings. Flood Warning Coordinator, or alternate, and HCA Water Resources Engineering staff to review the potential flooding impacts of a dam break. HCA Water Resources Engineering staff to monitor downstream areas for indications of channel capacity exceedences or flooding, using data collected by the HCA gauge station network and site observations (as required). Flood Warning Coordinator or alternate to provide advisory role regarding evacuation procedures and required times for evacuation to appropriate City of Hamilton staff (Emergency Management staff and Emergency Control Group members), regional / OPP police. 	<ul style="list-style-type: none"> Flood Warning Coordinator, or alternate, to notify the appropriate HCA staff, the HCA Flood Control Centre (if opened), the HCA Chief Administrative Officer and HCA Director of Planning and Engineering. Dam operator to notify the Flood Warning Coordinator, or alternate - updated dam conditions and dam low flow valve or stop log settings. Flood Warning Coordinator, or alternate, to advise the City of Hamilton as to Township roads that may be flooded should a dam break occur or significant increase in discharge occur due to low flow valve and stop log setting changes. If required, Flood Warning Coordinator, or alternate, to issue flood bulletins (Watershed Conditions Statement, Flood Watch or Flood Warning, as required). Flood bulletins are based on current and forecasted weather, watercourse and flood conditions. Flood bulletins are also based on available inundation mapping of potential dam break scenarios and flood plain mapping for Spencer Creek. Flood Warning Coordinator, or alternate, to notify the City of Hamilton, police, Local Response Coordinator of the MNR and all other agencies required, as necessary regarding potential dam failure conditions and potential impacts of dam failure. Flood Warning Coordinator, or alternate, to notify the appropriate HCA staff, the HCA Flood Control Centre (if opened), the HCA Chief Administrative Officer, and HCA Director of Planning and Engineering. 	<p>HOURLY or DAILY</p> <ul style="list-style-type: none"> Water discharge, headwater, tailwater elevations and rate of change Weather conditions Dam conditions Photographs Downstream flooding conditions (as required) 	
<p>Dam overtopping or dam break due to:</p> <ul style="list-style-type: none"> unusual or extreme weather forecasts for the area (hurricanes, tornados, etc.) ice jams access road washout dam sabotage Emergence of boils or springs downstream of the dam Dam drop inlet structure damage or failure 	<ul style="list-style-type: none"> Dam operator to complete inspections of the dam on a daily interval, or at a smaller interval as directed by the Flood Warning Coordinator, or alternate. Focus of the inspections should be on changes in conditions of the embankment and drop inlet control structure, as well as changes in reservoir water level. Procedure as per Section 8 of the OMSS Manual (exp, 2013), unless otherwise directed by the Flood Warning Coordinator. Under the direction of the Flood Warning Coordinator, or alternate, dam operator to gradually open low flow valve and remove stop logs to maximum safe flow capacity, to lower reservoir water levels {Procedure as per Section 6.3 of the OMSS Manual (exp, 2013)}. Under the direction of the HCA Flood Warning Coordinator or alternate, dam operator to complete additional preventative actions. 	<ul style="list-style-type: none"> Flood Warning Coordinator, or alternate, and HCA Water Resources Engineering staff to review the potential impacts on downstream areas due to increased discharge from the dam as a result of changes to the dam low flow valve and stop log settings. Flood Warning Coordinator, or alternate, and HCA Water Resources Engineering staff to review the potential flooding impacts of a dam break. HCA Water Resources Engineering staff to monitor downstream areas for indications of channel capacity exceedences or flooding, using data collected by the HCA gauge station network and site observations (as required). Flood Warning Coordinator or alternate to provide advisory role regarding evacuation procedures and required times for evacuation to appropriate City of Hamilton staff (Emergency Management staff and 	<ul style="list-style-type: none"> Dam operator to notify the Flood Warning Coordinator, or alternate - updated dam conditions, dam low flow valve or stop log settings and dam water levels. Flood Warning Coordinator, or alternate, to advise the City of Hamilton as to Township roads that may be flooded should a dam break or high dam water levels occur. Also if significant increases in discharge occur due to low flow valve and stop log setting changes. If required, Flood Warning Coordinator, or alternate, to issue flood bulletins (Watershed Conditions Statement, Flood Watch or Flood Warning, as required). Flood bulletins are based on current and forecasted weather, watercourse and flood conditions. Flood bulletins are also based on available inundation mapping of potential dam break scenarios and flood plain mapping for Spencer Creek. Flood Warning Coordinator, or alternate, to notify Flood Warning Coordinator, or alternate, to notify the City of Hamilton, police, Local Response Coordinator of the MNR and all other agencies required, as necessary regarding potential dam failure conditions and potential impacts of dam failure. 	<p>HOURLY or DAILY</p> <ul style="list-style-type: none"> Water discharge, headwater, tailwater elevations and rate of change Weather conditions Dam conditions Photographs Downstream flooding conditions (as required) 	

			Emergency Control Group members), regional / OPP police.	<ul style="list-style-type: none"> Flood Warning Coordinator, or alternate, to notify the appropriate HCA staff, the HCA Flood Control Centre (if opened), the HCA Chief Administrative Officer, and HCA Director of Planning and Engineering. 	
Dam Failure or Imminent Dam Failure	<p>Dam break or dam overtopping due to:</p> <ul style="list-style-type: none"> Dam Break Excessive erosion, cracking, movement, settlement, discharge of fines, and riprap rock protection displacement in the dam embankment Excessive seepage through the dam embankment Whirlpool in headpond Boils or springs downstream of the dam Forecasted flood levels at the upstream side of the dam greater than the crest elevation of the dam earth embankment (277.30 m) Unusual or extreme weather actively occurring in the area (hurricanes, tornados, etc.) 	<ul style="list-style-type: none"> If safe to do so, dam operator to complete inspections of the dam on an hourly interval, or at a smaller interval as directed by the Flood Warning Coordinator, or alternate,. Focus of the inspections should be on changes in conditions of the embankment and drop inlet control structure, as well as changes in reservoir water level. Procedure as per Section 8 of the OMSS Manual (exp, 2013), unless otherwise directed by the Flood Warning Coordinator. 	<ul style="list-style-type: none"> Advisory role regarding restricting access to dam and flooded areas. This can be accomplished by closing the access road to the dam and any other downstream roads. This should be ordered and coordinated by the City of Hamilton Emergency Control Group / Emergency Management staff and regional police / OPP, with technical advice provided by the Flood Warning Coordinator, or alternate. Evacuation of HCA staff from potential inundation areas. HCA Water Resources Engineering staff to update the assessment of potential flooding impacts due to a dam break, based on current conditions. HCA Water Resources Engineering staff to monitor downstream areas for indications of channel capacity exceedences or flooding, using data collected by the HCA gauge station network and site observations (as required). Advisory role regarding evacuation of the potential inundation area. An evacuation order should be ordered and coordinated by appropriate City of Hamilton staff (Emergency Management staff and Emergency Control Group members), regional / OPP police, with technical advice regarding potential inundation provided by the Flood Warning Coordinator or alternate. 	<ul style="list-style-type: none"> Dam operator to notify the Flood Warning Coordinator, or alternate - updated dam conditions and water levels. Flood Warning Coordinator, or alternate, to advise the City of Hamilton as to Township roads that will be flooded by a dam break or dam overtopping. Flood Warning Coordinator, or alternate, to issue flood bulletin updates (Watershed Conditions Statement, Flood Watch or Flood Warning, as required). Flood bulletins are based on current and forecasted weather, watercourse and flood conditions. Flood bulletins are also based on available inundation mapping of potential dam break scenarios and flood plain mapping for Spencer Creek. Flood Warning Coordinator, or alternate, to notify the City of Hamilton, police, Local Response Coordinator of the MNR and all other agencies required, as necessary regarding potential dam failure conditions and potential impacts of dam failure. Dam operator to issue an immediate warning to downstream residents and any residents in the immediate vicinity of the dam, based on dam conditions and flood inundation mapping. Flood Warning Coordinator, or alternate, to notify the appropriate HCA staff, the HCA Flood Control Centre (if opened), the HCA Chief Administrative Officer, and HCA Director of Planning and Engineering. 	<p>HOURLY</p> <ul style="list-style-type: none"> Water discharge, headwater, tailwater elevations and rate of change Weather conditions Dam conditions Photographs Downstream flooding conditions (as required) Description and location of dam break
Certain Emergencies Not Involving a Dam Failure or Flood Event	<ul style="list-style-type: none"> Major Spills Earthquake 	<ul style="list-style-type: none"> If safe to do so, dam operator to complete inspections of the dam on a daily interval, or at a smaller interval as directed by the Flood Warning Coordinator, or alternate. Focus of the inspections should be on conditions of the embankment and drop inlet control structure, as well as changes in reservoir water level. Procedure as per Section 8 of the OMSS Manual (exp, 2013), unless otherwise directed by the Flood Warning Coordinator. If required as a result of an earthquake and corresponding dam structural damage, under the direction of the Flood Warning Coordinator, or alternate, dam operator to 	<ul style="list-style-type: none"> Advisory role regarding restricting access to the dam, and potentially to flooded areas if necessary. This can be accomplished by closing the access road to the dam and any other downstream roads. This should be ordered and coordinated by the City of Hamilton Emergency Control Group / Emergency Management staff and regional police / OPP, with technical advice provided by the Flood Warning Coordinator, or alternate. Evacuation of HCA staff from site and potential inundation area. If dam structural damage by earthquake, 	<ul style="list-style-type: none"> Dam operator to notify HCA Flood Warning Coordinator of dam conditions and emergency details. As required, HCA staff to notify Emergency Response Team (911). Flood Warning Coordinator, or alternate, to notify the City of Hamilton, fire, police, Local Response Coordinator of the MNR and all other agencies required, as necessary regarding site conditions If required, Flood Warning Coordinator, or alternate, to notify the City of Hamilton, police, Local Response Coordinator of the MNR and all other agencies required, as necessary regarding potential dam failure conditions and potential impacts of dam failure. 	<ul style="list-style-type: none"> Nature of Problem Weather conditions Dam conditions Photographs

		<p>gradually open low flow valve and/or remove stop logs to maximum safe flow capacity, to lower reservoir water levels {Procedure as per Section 6.3 of the OMSS Manual (exp, 2013)}.</p> <ul style="list-style-type: none"> • If required as a result of a major spill, under the direction of the Flood Warning Coordinator, or alternate, dam operator to close the low flow valve and/or add stop logs to provide the maximum safe storage capacity, to contain the spill within the reservoir. • If required, under the direction of the HCA Flood Warning Coordinator or alternate, dam operator to complete additional preventative actions. 	<p>Flood Warning Coordinator, or alternate, and HCA Water Resources Engineering staff to review the potential flooding impacts of a potential dam break.</p> <ul style="list-style-type: none"> • HCA Water Resources Engineering staff to monitor downstream areas for indications of channel capacity exceedences or flooding, using data collected by the HCA gauge station network and site observations (as required). • If required, advisory role regarding evacuation of the potential inundation area. An evacuation order should be ordered and coordinated by appropriate City of Hamilton staff (Emergency Management staff and Emergency Control Group members), regional / OPP police, with technical advice regarding potential inundation provided by the Flood Warning Coordinator or alternate. 	<ul style="list-style-type: none"> • If required, Flood Warning Coordinator, or alternate, to issue flood bulletins (Watershed Conditions Statement, Flood Watch or Flood Warning, as required). • Flood Warning Coordinator, or alternate, to notify the appropriate HCA staff, the HCA Flood Control Centre (if opened), the HCA Chief Administrative Officer, and HCA Director of Planning and Engineering. 	
--	--	--	---	--	--

Note 1: Forecasted dam water levels to be based on flood levels expected to result from a recent or short-term forecasted rainfall and / or snow melt event

3.1 Flood Event Without Dam Failure

Potential dam emergency conditions categorized within this response level involve flood levels at the upstream side of the dam not expected to result in dam overtopping or dam break.

The dam flood level conditions listed in the Emergency Action Table may be based on actual current dam water levels. Alternatively, in some instances the dam flood level conditions may be based on forecasted dam water levels, based on expected flood levels resulting from a recent or short-term forecasted rainfall and / or snow melt event. The Emergency Action Table states when conditions are to be based on current dam water levels, forecasted dam water levels, or either at the discretion of the Water Resource Engineering staff / Flood Warning Coordinator or alternate.

The operational actions are as per those stated in the Operation, Maintenance, Surveillance and Safety (OMSS) Manual (exp, 2013). The OMSS Section 6 provides additional information regarding the operation of the dam during and following flooding or flood emergency events occurring during all seasons.

Potential preventive actions at the dam may include opening the low flow valve fully and removing some or all of the stoplogs to a maximum safe flow capacity, under the direction of the Flood Warning Coordinator, or alternate. Procedure as per Section 6.3 of the OMSS Manual (exp, 2013). The HCA Flood Warning Coordinator or alternate will evaluate the potential downstream flooding impacts of removing any stoplogs, as well as whether it is potentially viable and safe to remove only some of the stoplogs. To remove all of the stoplogs quickly, a lifting device (front-end loader, etc) can be used to lift the chains connected to the steel stanchions that hold the stoplogs.

Additional emergency actions may include:

- HCA Water Resources Engineering staff to monitor downstream areas for early indications of channel capacity exceedences or flooding, using data collected by the HCA gauge station network and site observations (as required); and,
- Flood Warning Coordinator or alternate and HCA Water Resources Engineering staff to review the potential impacts of the removal of the stop logs on downstream areas.

3.2 Potential Dam Failure Developing

Potential dam emergency conditions categorized within this response level involve possible dam overtopping or dam break which is not imminent. This includes:

- Potential dam overtopping or dam break conditions based on current or forecasted flood levels at the upstream side of the dam greater than the Maximum Design Flood Level (276.16 m);

- Potential dam break conditions based on observed signs of erosion, cracking, movement, settlement and riprap rock protection displacement in the dam embankment;
- Potential dam break conditions based on observed signs of increased seepage through the dam embankment;
- Potential dam overtopping or dam break conditions based on unusual or extreme weather forecasts for the area (hurricanes, tornados, etc.);
- Potential dam overtopping or dam break conditions based on ice jams;
- Potential dam overtopping or dam break conditions based on access road washout;
- Potential dam overtopping or dam break conditions based on dam sabotage;
- Potential dam overtopping or dam break conditions based on failure or damage to the drop inlet structure; and,
- Potential dam break conditions based on the emerging presence of boils or springs downstream of the dam.

Potential preventive actions at the dam may include:

- Reduction in Freeboard and/or Loss of Dam Crest Width:
 - Under the direction of the Flood Warning Coordinator, or alternate, dam operator to gradually open low flow valve and remove stop logs to maximum safe flow capacity, to lower reservoir water levels to an elevation below the damaged area. Procedure as per Section 6.3 of the OMSS Manual (exp, 2013).
 - Place additional riprap or sandbags in damaged areas to prevent further embankment erosion.
 - Restore dam crest elevation with sandbags or earth and rockfill.
 - Continue close inspection of the damaged area until the storm is over.
- Potential Overtopping of Dam by Flood Waters:
 - Place sandbags along the crest to raise the dam crest elevation and ensure controlled discharge through the drop inlet structure;
 - Create a controlled breach in a low embankment section where the foundation materials are erosion resistant. *CAUTION: Use only as a last resort.*
- A Slide on the Upstream or Downstream Slope of the Embankment:
 - Under the direction of the Flood Warning Coordinator, or alternate, dam operator to open low flow valve and remove stop logs to maximum safe flow capacity, to lower reservoir water levels to an elevation considered safe given the slide condition. Procedure as per Section 6.3 of the OMSS Manual (exp, 2013).

- If the discharge outlets are damaged or blocked, pumping, siphoning, or controlled breach may be required.
- Restore embankment if required by placing sandbags or filling in the top of the slide.
- Stabilize slides on the downstream slope by weighing the toe area with additional soil, rock or gravel.
- Erosion, Seepage or Leakage (Piping) through the Embankment, Foundation or Abutments:
 - Identify extent of erosion or area(s) of seepage and color of effluent.
 - Under the direction of the Flood Warning Coordinator, or alternate, dam operator to open low flow valve and remove stop logs to maximum safe flow capacity, to decrease flows to non-erosive velocity. Procedure as per Section 6.3 of the OMSS Manual (exp, 2013). Pumping of water from reservoir may also be required.
 - Plug the flow with whatever material is available (e.g. hay bales, bentonite or plastic sheeting if the entrance to the leak is in the reservoir).
 - Place a blanket filter (i.e. a protective sand and gravel filter) over the exit area to hold material in place.
 - Continue lowering the water level until a safe elevation is reached.
 - Continue operating at a reduced level until repairs are made. Maintain site supervision until the situation is under control.
- A Failure of the Outlet Structure:
 - Implement temporary measures to protect the damaged structure, such as closing an outlet or providing temporary protection for a damaged spillway.
 - Employ experienced professional divers if necessary to assess the problem and possibly implement repairs.
 - Under the direction of the Flood Warning Coordinator, or alternate, dam operator to open low flow valve and remove stop logs to maximum safe flow capacity, to lower the water level to a safe elevation. Procedure as per Section 6.3 of the OMSS Manual (exp, 2013). If the outlets are inoperable, pumping, siphoning or a controlled breach may be required.
- A Mass Movement of the Dam on its Foundation (Spreading or Mass Sliding Failure):
 - Under the direction of the Flood Warning Coordinator, or alternate, dam operator to open low flow valve and remove stop logs to immediately lower the water level until excessive movement stops.

- Continue lowering the water level until a safe level is reached.
- Continue operation at a reduced level until repairs are made.

Inspections of dam conditions may significantly reduce the risk of an unexpected dam break or dam overtopping. The inspections are to be at daily interval, or at a smaller interval as directed by the Flood Warning Coordinator, or alternate. The inspection procedure is to be as per Section 8 of the OMSS Manual (exp, 2013), unless otherwise directed by the Flood Warning Coordinator. The Emergency Action Table summarizes the focus of inspections for each potential dam emergency condition. During site inspections, HCA staff is responsible for identifying any such warning signs and notifying the Manager of Water Resources Engineering and, if an emergency appears imminent, the Flood Warning Coordinator or alternate. If during an inspection, HCA staff discovers something unusual that he/she is not familiar with, the Manager of Water Resources Engineering should be contacted immediately for advice. An emergency should not be ruled out unless it can be determined that it is not an emergency.

Additional emergency actions may include:

- HCA Water Resources Engineering staff to monitor downstream areas for indications of channel capacity exceedences or flooding, using data collected by the HCA gauge station network and site observations (as required);
- Flood Warning Coordinator or alternate and HCA Water Resources Engineering staff to review the potential flooding impacts of a dam break;
- Flood Warning Coordinator or alternate and HCA Water Resources Engineering staff to review the potential impacts on downstream areas due to increased discharge from the dam as a result of changes to the dam low flow valve and/or stop log settings; and,
- Advisory role regarding evacuation procedures and required times for evacuation.

Flood Warning Coordinator or alternate to provide advisory role regarding evacuation procedures and required times for evacuation to appropriate City of Hamilton staff (Emergency Management staff and Emergency Control Group members), regional / OPP police.

3.3 Dam Failure or Imminent Dam Failure

Potential dam emergency conditions categorized within this response level involve dam break or dam overtopping which is imminent, not avoidable or has already occurred.

Dam break may involve failure of the dam embankment, foundations, or concrete inlet drop structure, resulting in a sudden release of impounded water. The resulting flood hydrograph peak, due to the dam failure, may be very high leading to flood damages. The amount of warning time available in the event of an unexpected failure of the concrete structures or earth embankment is difficult to quantify. A dam break is usually preceded by warning signs that indicate the dam, the foundation, or the control structure is deteriorating.

Dam failure can also involve overtopping of the dam due to high water levels at the upstream side of the dam.

Possible dam failure or imminent dam failure conditions may include:

- An occurring dam break;
- Imminent dam break based on excessive erosion, cracking, movement, settlement, discharge of fines, and riprap rock protection displacement in the dam embankment;
- Imminent dam break based on excessive seepage through the dam embankment;
- Imminent dam break based on the presence of whirlpools in the headpond;
- Imminent dam break based on the presence of boils or springs downstream of the dam;
- Dam overtopping or dam break based on forecasted flood levels at the upstream side of the dam greater than the crest elevation of the dam earth embankment (277.30 m); and,
- Imminent dam overtopping or dam break based on unusual or extreme weather actively occurring in the area (hurricanes, tornados, etc.).

Inspections of dam conditions may significantly reduce the risk of an unexpected dam break or dam overtopping. The inspections are to be at hourly intervals, or at a smaller interval as directed by the Flood Warning Coordinator, or alternate. The inspection procedure is to be as per Section 8 of the OMSS Manual (exp, 2013), unless otherwise directed by the Flood Warning Coordinator. The Emergency Action Table summarizes the focus of inspections. During site inspections, if safe to access site, HCA staff are responsible for identifying any such warning signs and notifying the Manager of Water Resources Engineering and, if an emergency appears imminent, the Flood Warning Coordinator or alternate. If during an inspection, HCA staff discovers something unusual that he/she is not familiar with, the Manager of Water Resources Engineering should be contacted immediately for advice. An emergency should not be ruled out unless it can be determined that it is not an emergency.

Additional emergency actions may include:

- HCA staff are to be evacuated from potential areas of inundation;
- HCA Water Resources Engineering staff to update the assessment of potential flooding impacts due to a dam break, based on current conditions;
- HCA Water Resources Engineering staff to monitor downstream areas for indications of channel capacity exceedences or flooding, using data collected by the HCA gauge station network and site observations (as required);
- Advisory role in restricting access to the dam and potentially flooded areas, for public safety.
- Advisory role regarding evacuation procedures and required times for evacuation; and,
- Technical advisory role regarding evacuation of potential inundation area.

In the event of an emergency, restricting access to the dam and flooded areas may be required for public safety. This can be accomplished by closing the access road to the dam and any other downstream roads. This should be ordered and coordinated by the City of Hamilton Emergency Control Group / Emergency Management staff and regional police / OPP, with technical advice provided by the Flood Warning Coordinator, or alternate.

Flood Warning Coordinator or alternate to provide advisory role regarding evacuation procedures and required times for evacuation to appropriate City of Hamilton staff (Emergency Management staff and Emergency Control Group members), regional / OPP police.

During an extreme flood and/or a dam failure event, evacuation in the potential inundation area may be necessary. An evacuation should be ordered and coordinated by appropriate City of Hamilton staff (Emergency Management staff and Emergency Control Group members) and regional police / OPP, with technical advice regarding potential inundation provided by the Flood Warning Coordinator, or alternate.

3.4 Certain emergencies not involving a dam failure or flood event (Major Spills and Earthquakes)

Potential dam emergency conditions categorized within this response level are earthquakes and major spills, which are not necessarily of a dam failure or flooding nature. Details regarding emergency procedures for other major emergencies and dam-related problems are provided in the HCA FEM.

Potential preventative actions may include:

- If required as a result of an earthquake and corresponding dam structural damage, under the direction of the Flood Warning Coordinator, or alternate, dam operator to gradually open low flow valve and/or remove stop logs to maximum safe flow capacity, to lower reservoir water levels. Procedure as per Section 6.3 of the OMSS Manual (exp, 2012); Pumping of water may be required;
- If required as a result of a major spill, under the direction of the Flood Warning Coordinator, or alternate, dam operator to close the low flow valve and/or add stop logs to provide the maximum safe storage capacity, to contain the spill within the reservoir; and,
- If required, under the direction of the HCA Flood Warning Coordinator or alternate, dam operator to complete additional preventative actions.

Inspections of dam conditions may significantly reduce the risk of an unexpected dam break or dam overtopping. The inspections are to be at daily intervals, or at a smaller interval as directed by the Flood Warning Coordinator, or alternate. The inspection procedure is to be as per Section 8 of the OMSS Manual (exp, 2013), unless otherwise directed by the Flood Warning Coordinator. The Emergency Action Table summarizes the focus of inspections. During site inspections, if safe to access site, HCA staff are responsible for identifying any such warning signs and notifying the Manager of Water Resources Engineering and, if an emergency appears imminent, the Flood Warning Coordinator or alternate. If during an inspection, HCA staff discovers something unusual that he/she is not familiar with, the Manager of Water Resources Engineering should be contacted immediately for advice. An emergency should not be ruled out unless it can be determined that it is not an emergency.

Additional emergency actions may include:

- Advisory role in restricting access to the dam, and potentially to flooded areas if necessary;
- HCA staff are to be evacuated from potential areas of inundation;
- If dam structural damage by earthquake, HCA Water Resources Engineering staff to review the potential flooding impacts of a potential dam break;

- HCA Water Resources Engineering staff to monitor downstream areas for indications of channel capacity exceedences or flooding, using data collected by the HCA gauge station network and site observations (as required); and,
- Technical advisory role regarding evacuation of potential inundation area, if required.

In the event of an emergency, restricting access to the dam, as well as potentially to flooded areas if necessary, may be required for public safety. This can be accomplished by closing the access road to the dam and any other downstream roads. This should be ordered and coordinated by the City of Hamilton Emergency Control Group / Emergency Management staff and regional police / OPP, with technical advice provided by the Flood Warning Coordinator, or alternate.

During an extreme flood and/or a dam failure event, evacuation in the potential inundation area may be necessary. An evacuation should be ordered and coordinated by appropriate City of Hamilton staff (Emergency Management staff and Emergency Control Group members) and regional police / OPP, with technical advice regarding potential inundation provided by the Flood Warning Coordinator, or alternate.

4 Notification Procedures

This Valens Dam EPP is to be carried out in conjunction with the HCA Flood Emergency Manual (FEM). The HCA FEM contains detailed procedures to be followed by various parties in the event of extreme weather with flooding potential as well as other major emergencies and dam-related problems. The HCA FEM also contains additional contact information for use by the Flood Warning Coordinator, or alternate.

4.1 Emergency Flood Event or a Potential, Imminent or Occurring Dam Failure Situation

Table 4-1 shows a flow chart of the notification procedure in the event of an emergency flood event without dam failure, potential dam failure developing, or dam failure / imminent dam failure. This notification procedure is also to be used for major spill and earthquake emergencies.

Upon an observation of an emergency situation, HCA staff or the public must notify the Flood Warning Coordinator, or alternate, either through:

- direct communication with the Flood Warning Coordinator;
- notifying the Duty Officer who in turn informs the Flood Warning Coordinator; or
- contacting 911, which will then contact the HCA Duty Officer, who in turn informs the Flood Warning Coordinator.

Once the Flood Warning Coordinator, or alternate, has been notified, they will assess the level of the emergency condition and the appropriate actions that should be taken to mitigate the potential damages.

As shown in Table 4-1, the Flood Warning Coordinator, or alternate, will be responsible for then notifying, as required by the level of the emergency condition, the following:

- the City of Hamilton;
- police;
- appropriate HCA staff, including the dam operators;
- Local Response Coordinator of the MNR;
- SWMC;
- other external agencies, as required;
- the media;
- district school boards; and,
- the HCA Flood Control Centre. Refer to Section 4.2 for additional details regarding the City of Hamilton EOC, Provincial EOC and HCA Flood Control Centre.

Subsequent communications between the Flood Warning Coordinator, or alternate, and various parties, including the dam operators, may be required to provide updates as to the status of the emergency situation. Depending on the type of emergency or emergency conditions, other contacts and actions may be required.

The Emergency Action Table summarizes the required notifications from the time when the Flood Warning Coordinator, or alternate, has been initially notified of the emergency situation.

Typically, the Flood Warning Coordinator, or alternate, will communicate flood emergency warnings to the public through flood bulletins issued to the City of Hamilton, police and news media. Flood bulletins consist of Watershed Conditions Statement, Flood Watch or Flood Warning, as required, and are based on current and forecasted weather, watercourse and flood conditions. Flood bulletins are also based on available flood plain mapping for Spencer Creek, as well as inundation mapping of potential dam break scenarios (sunny day and/or inflow design flood), as per Valens Dam – Dam Break Analysis, (exp 2012).

Initial notifications of flooding conditions to other parties may often occur through the HCA flood bulletins as well.

The Flood Warning Coordinator, or alternate, is to advise the City of Hamilton as to Township roads that may potentially be flooded by high dam water levels, a dam break or dam overtopping.

The Flood Warning Coordinator, or alternate, will also notify City of Hamilton staff, police, Local Response Coordinator of the MNR and all other agencies required, as necessary, regarding potential dam failure conditions and potential impacts of dam failure.

For a dam failure or imminent dam failure of the Valens Dam, immediate warnings to residents can be coordinated with the assistance of regional fire, regional police / OPP, and the City of Hamilton. Immediate warnings may involve multiple forms of communication. Dam operators are to issue an immediate warning to any residents in the potential inundation area. The potential inundation area is based on dam conditions and previously developed flood inundation mapping of potential dam break scenarios (sunny day and/or inflow design flood), as per the Valens Dam – Dam Break Analysis, (exp 2012). In addition, dam operators are to issue immediate warning to any residents within the immediate vicinity of the Valens dam. Section 4.4 provides the location of residents within the potential inundation area for a dam break during an Inflow Design Flood event, as per the Valens Dam – Dam Break Analysis, (exp 2012).

4.2 City of Hamilton Emergency Planning, City of Hamilton Emergency Operations Centre, and HCA Flood Control Centre

4.2.1 City of Hamilton Emergency Planning

The City of Hamilton emergency planning details are documented in the City of Hamilton Municipal Emergency Plan (October 2008), in accordance with the Emergency Management Act. The following information is a summary of the emergency plan details, excerpted from this document.

The plan details the administration, co-ordination and implementation of response measures taken by the City of Hamilton during any emergency.

A responding agency or municipal department is likely to be the first on site authority to an emergency. The ranking officer for fire, police, EMS or a senior municipal official (or their designate) should personally assume control at the site of an emergency or arrange for someone on-site to take charge immediately until an Emergency Site Co-ordinator (ESC) is appointed.

If, in the judgement of the senior on-site official, the situation requires a more co-ordinated response or that resources are required beyond their immediate control, the senior on-site official must contact their most senior departmental official, in accordance with any existing departmental reporting procedure.

The Emergency Control Group (ECG) consists of the Mayor of Hamilton, the City Manager and the heads of all City departments, selected agencies and community partners. The ECG is responsible for leading, managing and coordinating City's emergency response and recovery activities as well as ensuring the continuing operations of municipal government. The Emergency Control Group is responsible for advising the Head of Council on all actions taken to support emergency workers at the emergency site, evacuation centres or any other location where staff, people, or volunteers are working to respond to an emergency. These actions include informing the public regarding issues of concern, issuing authoritative messages to the public through the media, providing the co-ordination and support necessary to respond to and mitigate the emergency situation, and ensuring that adequate emergency resources are maintained outside of and apart from the emergency site.

The ECG may only be activated by members of the ECG or their alternates. Any member of the ECG has the authority to activate the Emergency Notification Procedure by contacting the Hamilton Police Communications Staff Supervisor. On receipt of an official message from a member of the ECG, the Hamilton Police Communications Staff will implement the procedure by notifying members in the order they appear in the City of Hamilton Municipal Emergency Plan Appendix 2: Emergency Notification List. Hamilton Police Communications Staff is responsible for initially notifying members of the Emergency Control Group (ECG) and members of the Emergency Support Group

(ESG), and instructing them to respond to the Emergency Operations Centre (EOC) or on “Alert” for an impending situation.

The Emergency Support Group (ESG) is comprised of municipal and/or other non-governmental officials, who may be required to advise the Mayor and the ECG during an emergency, and to work at their direction. Each member of the ECG will designate any required support staff (ESG) from within their own department, agency or service, to assist their ECG member as required from within the Emergency Support Group Meeting Room(s). Other ESG staff will be alerted according to their own internal departmental alerting procedure. The ESG is responsible for:

- Collecting and disseminating information on the emergency to their respective ECG representative;
- Ensuring emergency information and employee communications are disseminated throughout their respective departments and agencies;
- Maintaining a log outlining communications and actions taken; and,
- operating the telephones, voice radios, faxes, computers and relaying information to and from their ECG member to key personnel outside the EOC.

4.2.2 City of Hamilton Emergency Operations Centre

The City of Hamilton Emergency Operations Centre details are documented in the City of Hamilton Municipal Emergency Plan (October 2008). The following information is a summary of the emergency plan details, excerpted from this document.

The Emergency Operations Centre (EOC) is where the Emergency Control Group, the Emergency Support Group and other support personnel assemble to share information, evaluate options and make decisions regarding the response to the emergency, and provide support to the emergency site.

The City Manager is responsible for co-ordinating all operations within the Emergency Operations Centre.

The EOC has the following facilities:

- **Emergency Control Group Meeting Room** - a secure room for the ECG to conduct sensitive meetings equipped with network capabilities;
- **Emergency Support Group Meeting Room(s)** - a meeting room(s) for the ESG with appropriate voice radios, phones, faxes, access to a photocopier, cable television, printers and computers connected to the corporate network;
- **Registration and Security Area** – an area dedicated to registering the EOC attendees and providing security to the facility;
- **Personal Needs** - appropriate comfort facilities including washrooms, quiet areas, kitchen facilities and showers;
- **Parking** - adequate parking for all staff;

- **Media Access** - access to an appropriate Media Information Centre with Press Conference area; and,
- **Back Up Power** - an adequate back-up power supply permitting the EOC to fully function without a municipal power supply.

Through their expertise and monitoring, the conservation authorities (Hamilton C.A. and Grand River C.A.) will be warning of an impending flood situation in advance of the actual event. Appropriate warnings will be sent by the authority to the city.

Should the situation develop to require a plan / EOC activation, provincial ministries not already known to be responding will be notified by the ECG through Emergency Management Ontario. A representative from the authority may be asked to join the EOC as an ad hoc member.

4.2.3 HCA Flood Control Centre

The HCA Flood Warning Coordinator, or alternate, will advise and recommend to the City of Hamilton that a flood emergency be declared, based on current and forecasted conditions.

If the City of Hamilton declares a municipal flood emergency, a 24 hour operational HCA Flood Control Centre (FCC) will be activated, led and coordinated by the HCA Flood Warning Coordinator, or alternate. The FCC will be located at the City of Hamilton EOC.

The HCA Flood Warning Coordinator, or alternate, may also advise and recommend that the City of Hamilton request provincial assistance, through the Local Response Coordinator of the Ministry of Natural Resources, if municipal resources are insufficient to meet a flood emergency. The FCC and Flood Warning Coordinator will provide technical information and advice to support this request for provincial assistance. Through the Provincial Flood Contingency Plan, the Minister of Natural Resources is responsible for declaring a provincial flood emergency. Declaration of a provincial flood emergency may include the assembly of a Provincial Emergency Control Group and Provincial EOC. Should a provincial EOC be assembled, the 24 hour operational HCA Flood Control Centre will likely continue to operate at the City of Hamilton EOC.

The internal notification procedure for the HCA FCC is shown in Table 4-2. The HCA Flood Warning Coordinator, or alternate, is responsible for providing information and technical advice between the FCC and the City of Hamilton EOC and provincial EOC, as required. The HCA Flood Warning Coordinator may delegate responsibility to the Technical Support Team and Communications Coordinator, for providing information and technical advice between the FCC and the City of Hamilton EOC and provincial EOC.

The HCA FEM provides additional details regarding the HCA Flood Control Centre.

4.3 Emergency Contact Numbers

- | | | | |
|----|---|---------------------|--|
| 1. | HCA Flood Warning Coordinator
/ Manager of Water Resources
Engineering: | Hazel Breton | BUS: 905-525-2181
Ext. 137
FAX: 905-648-4622
CEL: 905-515-5908
RES: 905-689-7268 |
| 2. | HCA Water Resources Engineer
/ Alternate Flood Warning
Coordinator: | Jonathan Bastien | BUS: 905-525-2181
Ext. 138
FAX: 905-648-4622
CEL: 905-515-3087
RES: 905-921-5650 |
| 3. | HCA Valens Dam
Superintendent | Gord Costie | BUS: 905-525-2183
Ext. 21
FAX: 905-659-1573
CEL: 905-973-4373
RES: 905-648-9339 |
| 4. | HCA Valens Dam
Assistant Superintendent | Joanna Sanche | BUS: 905-525-2183
Ext. 23
FAX: 905-659-1573
CEL: 905-531-6795 |
| 5. | HCA Director of Watershed
Planning and Engineering: | Scott Peck | BUS: 905-525-2181
Ext. 130
FAX: 905-648-4622
CEL: 905-512-4397
RES: 519-426-8526 |
| 6. | HCA Chief Administrative
Officer: | Chris Firth-Eagland | BUS: 905-525-2181
Ext. 110
FAX: 905-648-4622
CEL: 905-977-0741
RES: 905-627-1003 |
| 7. | HCA Director of Land
Management: | Tony Horvat | BUS: 905-525-2181
Ext. 113
FAX: 905-648-4622
CEL: 905-515-5881
RES: 905-544-7811 |

- | | | | |
|-----|--|---------------|--|
| 8. | HCA Manager of Fleet and Construction: | Don McConnell | BUS: 905-525-2181
Ext. 117
FAX: 905-648-4622
CEL: 905-537-1849
RES: 905-659-3403 |
| 9. | HCA Manager of Design and Development: | Sandy Bell | BUS: 905-525-2181
Ext. 190
FAX: 905-648-4622
CEL: 905-531-9095
RES: 905-335-6159 |
| 10. | HCA Marketing and Communications Coordinator: | Sarah Gauden | BUS: 905-525-2181
Ext. 151
FAX: 905-648-4622
CEL:
RES: |
| 11. | MNR Surface Water Monitoring Centre: | | BUS: 705-755-5201
FAX: 705-755-5038
CEL: 705-761-2044 |
| 12. | MNR Area Supervisor, Guelph District: | Ian Hagman | BUS: 519-826-4931
FAX: 519-826-4929
CEL: 519-835-1080
CEL: 519-994-4922 |
| 13. | MNR Provincial Emergency Response Coordinator: | | BUS: 866-898-7372
FAX: 705-945-5785 |
| 14. | City of Hamilton Emergency Dispatch: | | BUS: 905-546-2424
Ext. 0
After Hours: 905-546-2489 |
| 15. | City of Hamilton Mayor: | Bob Bratina | BUS: 905-546-4200
FAX: 905-546-2340 |
| 16. | City of Hamilton City Manager: | Chris Murray | BUS: 905-546-2424
Ext. 5420
FAX: 905-540-5141 |
| 17. | City of Hamilton Director of Operations: | Bryan Shynal | BUS: 905-546-2424
Ext. 4622
FAX: 905-546-4473
CEL: 289-260-0696 |

- | | | | |
|-----|--|-----------------|--|
| 18. | City of Hamilton Emergency Management Coordinator: | Carla McCracken | BUS: 905-546-2424
Ext. 5787
FAX: 905-546-3387
CEL: 905-961-8750
After Hours: 905-546-3333 Option 5 |
| 19. | City of Hamilton Emergency Management Coordinator: | Gina Cliffe | BUS: 905-546-2424
Ext. 6038
FAX: 905-546-3387
CEL: 905-961-8749
After Hours: 905-546-3333 Option 5 |
| 20. | City of Hamilton Chief Communications Officer: | Jim Friend | BUS: 905-546-2424
Ext. 3363
FAX: 905-546-3388
CEL: 905-961-9127
After Hours: 905-546-3333 Option 5 |
| 21. | Township of Puslinch Mayor: | Dennis Lever | BUS: 519-763-1226
FAX: 519-763-5846
CEL: 226-971-2067 |
| 22. | Township of Puslinch CAO: | Brenda Law | BUS: 519-763-1226
FAX: 519-763-5846
CEL: 519-831-5468
After Hours: 519-767-2462 |
| 23. | Regional Police / Fire Dispatch: | Emergency Line | TEL: 911 |
| 24. | Regional Police Chief of Police: | Glenn De Caire | BUS: 905-546-4710
FAX: 905-546-4752
After Hours: 905-546-4925 |
| 25. | Regional Police Deputy Chief of Police: | Ken Leendertse | BUS: 905-546-4701
FAX: 905-546-4752
CEL: 905-807-0178
After Hours: 905-546-4925 |
| 26. | Regional Police Deputy Chief of Police: | Eric Grit | BUS: 905-546-4703
FAX: 905-546-4752
CEL: 905-807-0616
After Hours: 905-546-4925 |
| 27. | OPP: | | BUS: 888-310-1122 |

28. Medical Emergencies: BUS: 911
29. Hamilton Fire Fire Chief: Rob Simonds BUS: 905-546-3343
FAX: 905-546-3344
CEL: 905-961-9111
After Hours: 905-546-3333 Option 5
30. Hamilton Fire Assistant Deputy: James Doyle BUS: 905-546-2424
Ext. 3377
FAX: 905-546-3344
CEL: 905-961-9114
After Hours: 905-546-3333 Option 5
31. Hamilton Fire Deputy Fire Chief: Dave Cunliffe BUS: 905-546-2424
Ext. 3340
FAX: 905-546-3344
CEL: 905-961-9112
After Hours: 905-546-3333 Option 5
32. Ministry of Transportation:

Refer to the HCA Flood Emergency Manual for additional emergency contact numbers, including those for individual staff at the City of Hamilton, and to news media.

4.4 Properties in the Potential Inundation Area

For a dam failure or imminent dam failure of the Valens Dam, immediate warnings to residents can be coordinated with the assistance of regional fire, regional police / OPP, and the City of Hamilton. Immediate warnings may involve multiple forms of communication.

Dam operators are to issue an immediate warning to any residents in the potential inundation area. The potential inundation area will be based on dam conditions and previously developed flood inundation mapping of potential dam break scenarios (sunny day and/or inflow design flood), as per the Valens Dam – Dam Break Analysis, (exp 2012). In addition, dam operators are to issue immediate warning to any residents within the immediate vicinity of the Valens dam.

Table 4-1 summarizes the location and contact details for properties within the potential inundation area for a dam break during an Inflow Design Flood event.

Figure 4.1 shows the location of properties within the potential inundation area for a dam break during an Inflow Design Flood event.

5 Preparedness Actions

5.1 Communications

Communication equipment must be kept in working order and ready to be used at any time. There is telephone communication at the Conservation Area office. Also, HCA staff has access to portable radios and cellular phones to be used for regular duties and for emergencies. The contact numbers for Valens Dam staff are:

- Office: (905) 525-2183
- Mobile:
 - Superintendent – Gord Costie: (905) 973-4373
 - Assistant Superintendent – Joanna Sanche: (905)-531-6795

Section 4.3 provided a listing of emergency contact information for HCA staff, City of Hamilton staff, police, fire and external agencies.

5.2 Dam Inspection

Regular inspection (surveillance) is an essential component of a complete and effective dam safety program. The purpose of a dam inspection program is to identify potential problems and unsafe conditions so that appropriate maintenance or rehabilitation can be implemented before major problems develop.

Three different levels of inspection are incorporated into the Valens Dam inspection program, as follows:

1. Dam Safety Review Inspection
2. Formal Inspections (including both annual and special inspections)
3. Routine Visual Inspections

The inspection procedures and details are described in Section 8 of the OMSS manual (exp, 2013).

5.3 Dam Maintenance

The required maintenance activities for Valens Dam include the following:

- maintenance on concrete and earth structures
- vegetation control
- instrumentation maintenance and repairs
- low flow valve maintenance and repairs

Section 9 of the OMSS manual (exp, 2013) provides a list of expected maintenance items, to be performed on an as-required basis.

5.4 Access to the Site

The dam can be accessed through private property from Valens Road. Figure 5-1 shows a suggested access route from the HCA office to Valens Dam. The travel time is approximately 30 minutes from HCA's office at 838 Mineral Springs Road, Ancaster.

The Valens Dam is an unattended dam, in that it is not attended 24 hours per day. However, HCA staff may be on site during regular working hours.

5.5 Security and Public Warning Systems

There is currently no security system installed at Valens Dam. There is also presently no public warning system installed at the Valens Dam. Public warning notices are made through flood bulletins distributed directly to the City, police and media.

5.6 Power Sources

There is currently no electrical power or emergency power source located at Valens Dam.

5.7 Response During Darkness

The dam area is not specifically lit during periods of darkness. HCA staff have access to battery-operated flashlights. They should be well maintained, kept in working condition and routinely checked.

If an emergency situation occurs during periods of darkness, HCA staff should follow the same procedures that are described in the Emergency Action Table.

5.8 Response During Adverse Weather

If an emergency situation occurs during periods of adverse weather, HCA staff should follow the same procedures that are described in the Emergency Action Table.

Adverse weather could include extremes of cold, snow, ice and storms. Special precautions when responding to an emergency under these conditions would include:

- Tractor and vehicle mounted snow plows to clear access road of ice and snow;
- Extra dry clothes;
- Knowledge of symptoms of hypothermia; and
- Personal safety/floatation devices, including survival floatation suits.

5.9 Emergency Supplies and Resources

In the event of an emergency, equipment (such as backhoes and bulldozers, as well as crane rentals), supplies (such as rock fill, concrete, lumber, electrical, etc), and personnel may be required. Both HCA internal supplies, as well as external suppliers are detailed below.

In addition, a first-aid kit is located in every HCA vehicle. Flotation life rings are available and stored in the workshop, but not stored directly at the dam.

5.9.1 Sources of Equipment

Internal Equipment

The following equipment is located at the HCA Valens Conservation Area workshop.

Bulldozer:
Backhoe:
Truck:
Tractor:
Steer:

The following equipment is located at the HCA Woodend works yard.

Bulldozer:	450 John Deere Dozer John Deere
Backhoe:	575 Ford Bubber Tired Backhoe-Extend-A-Hoe
Truck:	Tandem Dump Truck
Truck:	Single Axle Dump Truck
Crane:	1 Ton Crane Truck
Tractor:	Farm Tractors Wagons Agricultural Equipment
Steer:	260JD Skid Steer, 1840 Case Skitsteer, 510 Kubota Loader

External Equipment

Numerous contractors are resident in the region of Hamilton and would be able to provide equipment to HCA in the event of a Dam Safety Emergency. Currently, HCA does not have any existing agreements or arrangements with any contractors; therefore in an emergency situation, HCA staff would need to contact the contractors and procure the required equipment. The following tables contain contact information for contractors with heavy equipment, general equipment rentals and helicopter services. The information was extracted from the local telephone directory and from the internet directly. The following tables are for the HCA staff convenience only. A complete listing of the equipment can be obtained in the Hamilton Regional Yellow Pages.

**Table 7-1
Heavy Equipment Supplier List**

Company Name	Address	Contact Information	Availability 24 Hours
Titan Heavy Equipment Inc.	145 Nipissing Road, Milton, ON L9T 1R3	(905) 875-0772	
C M O Heavy Equipment Services Ltd.	85 Bowes Road, Concord, ON L4K 1H6	(905) 660-5305	

**Table 7-2
Crane Rental List**

Company Name	Address	Contact Information	Availability 24 Hours
Chiarot's Steel City Crane Service	756 Upper Ottawa Street, Hamilton, ON L8T 3V1	(905) 388-2016	
York Crane Rental Limited	687 Hwy 6, Waterdown, ON L0R 2H0	(905) 689-5311	
Aberfoyle Crane Rental	2 Portside Drive RR 1, Hannon, ON L0R 1P0	(905) 692-1879	

**Table 7-3
Equipment Rental List**

Company Name	Address	Contact Information	Availability 24 Hours
Home Depot Tool Rental	122 Martindale Crescent, Ancaster, ON L9K 1J9	(905) 304-6826	
Resource Equipment Ltd.	637 Parkdale Avenue North, Hamilton, ON L8H 5Z1	(905) 544-9544	
Hamilton Equipment Rental Centre	2701 Barton Street East, Hamilton, ON L8E 2J5	(905) 561-2481	

**Table 7-4
Helicopter Services List**

Company Name	Address	Contact Information	Availability 24 Hours
Four Seasons Aviation Ltd.	2450 Derry Road East, Mississauga, ON L5S 1B2	(905) 671-9644	
Niagara Helicopters Limited	3731 Victoria Avenue, Niagara Falls, ON L2E 6V5	(905) 357-5672	
National Helicopters Inc.	11339 Albion Vaughan Road RR1, Kleinburg, ON L0J 1C0	(905) 893 2727	

5.9.2 Internal Stockpiles

The following table summarizes the location and availability of HCA stockpiled materials that may be useful in an emergency event.

**Table 7-5
HCA Stocking Supplies and Materials List**

Supplies	ID	Intended Use Description	Size	Amount	Crew

5.9.3 External Source Materials

The following table summarizes contact information of contractors that may have materials available or stockpiled that could be available to HCA to use in an emergency.

**Table 7-6
External Supplies and Materials – Concrete Products**

Company Name	Address	Contact Information	Availability 24 Hours
Day & Campbell Ltd.	1074 Upper Wellington Street, Hamilton, ON L9A 3S6	(905) 385-5315	
Synstone Canada Inc.	76 Biggar Avenue, Hamilton, ON L8L 3Z4	(905) 549-1785	
Ferrell Builders Supply Ltd.	1549 Rymal Road East, Hamilton, ON L8W 3N2	(905) 387-1948	

**Table 7-7
External Supplies and Materials – Earth and Rock Fill Supplies**

Company Name	Address	Contact Information	Availability 24 Hours
Lafarge Canada Inc.	628 Hwy 5, Dundas, ON L9H 7L5	(905) 527-2744	
Flamboro Quarries	685 Brock Road, Dundas, ON L9H 5E4	(905) 627-3573	
Nelson Aggregate Co.	5362 Yonge, Beamsville, ON L0R 1B2	(905) 563-8226	

**Table 7-8
External Supplies and Materials – Lumber and Building Materials**

Company Name	Address	Contact Information	Availability 24 Hours
Home Depot Canada	122 Martindale Crescent, Ancaster, ON L9K 1J9	(905) 304-5900	
Lawson Lumber Co Ltd	260 Dunsmure, Hamilton, ON L8M 1S8	(905) 549-3501	
Rona Cashway Building Centres	1245 Rymal Rd E, Hamilton, ON L8W 3N1	(905) 383-3355	

**Table 7-9
External Supplies and Materials – Electrical Supplies**

Company Name	Address	Contact Information	Availability 24 Hours
Bain Electric	796 Garth Street, Hamilton, ON L9C 4K5	(905) 388-5888	
Tartan Electric Limited	7 Emming Court, Hamilton, ON L9C 4A1	(905) 574-1722	
Victor Electric & Equipment	8 Main St E, Hamilton, ON L8N 1E8	(905) 526-9021	

**Table 7-10
Labours and Contractors List**

Company Name	Address	Contact Information	Availability 24 Hours
Labourers International Union	44 Hoghson St. South, Hamilton L8N 2A7	(905) 522-7177	
Dufferin Construction	948 Dunsmure Rd., Hamilton, ON L8H 1J4	(905) 545-2001	
McNally Construction Inc.	1855 Barton St. E., Hamilton, ON L8H 2Y7	(905) 549-6561	

6 Inundation Maps

Determination of the Hazard Potential Classification (HPC) of a dam requires an incremental hazard assessment. The assessment assists in the determination of the Inflow Design Flood (IDF). As a by-product of the assessment, inundation maps are prepared to illustrate the extent of flooding under various dam break scenarios and the IDF.

A dam break analysis was undertaken by exp in 2012 (Valens Dam – Dam Break Analysis), in which the Valens Dam HPC was determined to be VERY HIGH and the IDF was selected as the flood 2/3 between the 1:1000 year flood and the PMF. Flood inundation maps for Sunny Day and IDF breaks were prepared and are attached in Appendix B.

7 Implementation

7.1 Local Coordination

This EPP was provided to local government, police, community representatives, and agencies responsible for emergency preparedness implementation in areas potentially affected by a dam emergency.

The HCA held coordination meetings with all parties included in the notification charts. At the coordination meeting, the HCA explained in general terms the objectives of the EPP, the potentially affected parties, the inundation maps, existing communication network and notification procedures.

All parties reviewed and commented on the draft EPP prior to it being finalized and distributed.

Once the various agencies were familiar with the EPP, HCA ensured that all parties were in agreement with respect to their individual roles and responsibilities during emergency events.

This communication between parties will be repeated periodically to ensure that any new hires are aware of individual rules and responsibilities.

An EPP coordinator may be assigned to take responsibility for EPP coordination, as well as any related tasks, such as updating and staff training / testing.

7.2 Staff Training of EPP

A detailed training program was implemented by HCA, which included the following:

- Training plans and schedules;
- Training of problem detection and evaluation;
- Training of use of Inundation maps;
- Training for use of equipment and communication system;
- Exercising plan and schedule;
- Evaluation of exercises; and,
- Follow-up and recommendations.

7.3 Updating and Reviewing the EPP

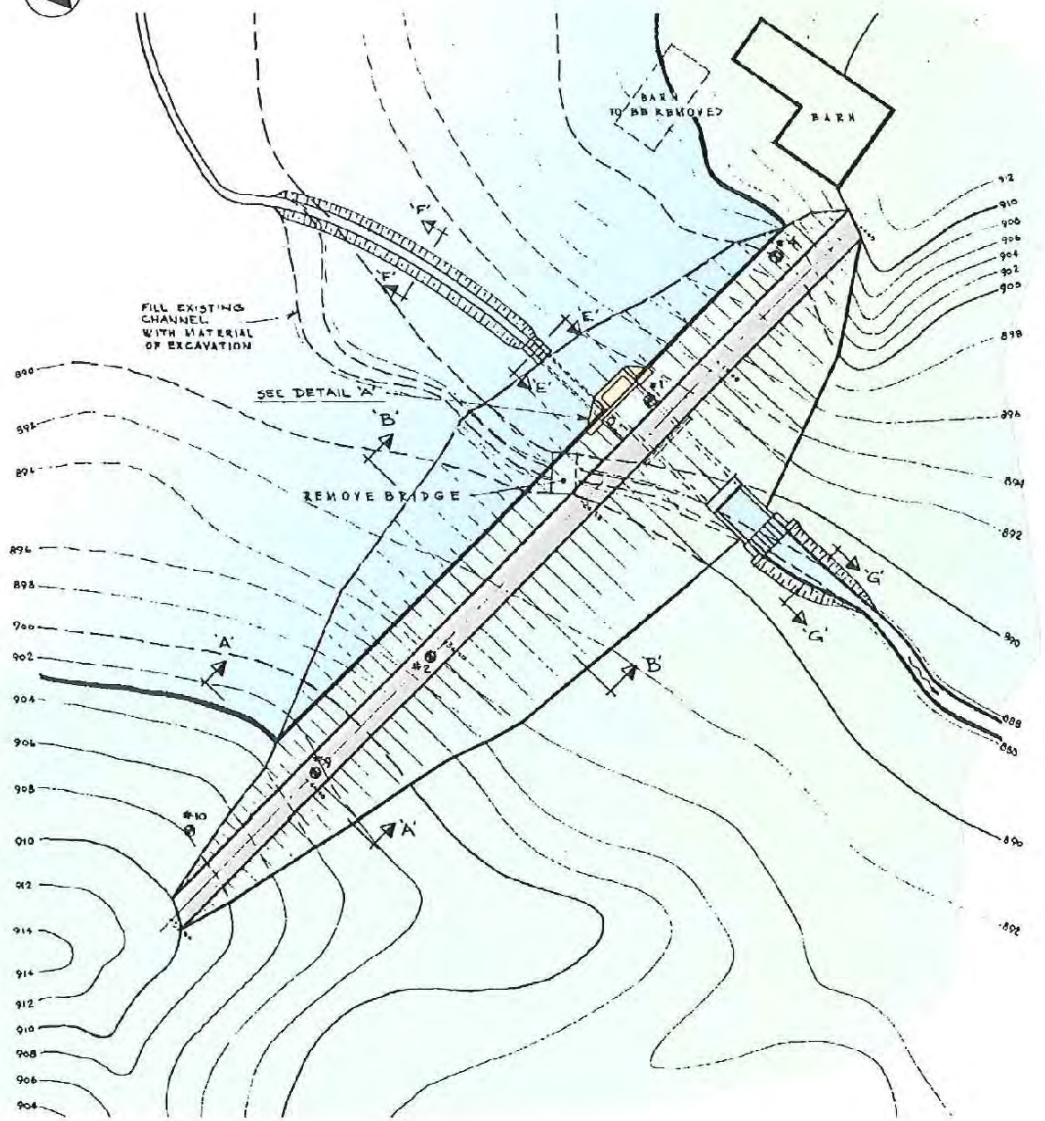
The reviewing and updating of the EPP will include the following items.

- Training as to the process for revisions and review;
- Annual review of EPP or other periodic review;
- Updating of Inundation maps;
- Identifying any new development or problems;
- Implementing into the EPP exercise lessons learned;
- Updating for personnel changes and contact information; and,
- Updating distribution lists.

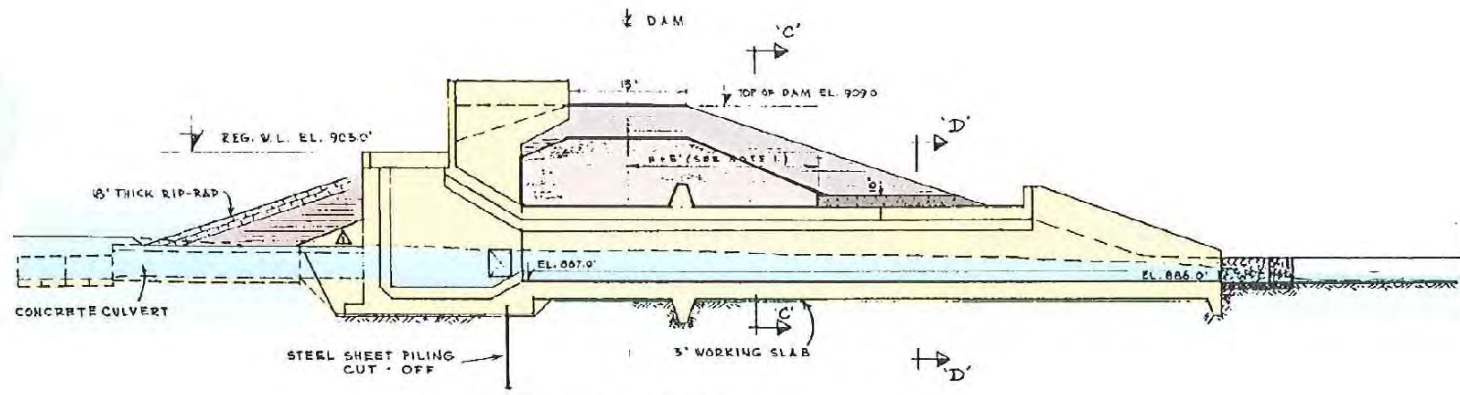
This page intentionally left blank.

APPENDIX A - DRAWINGS & DAM DATA SHEET

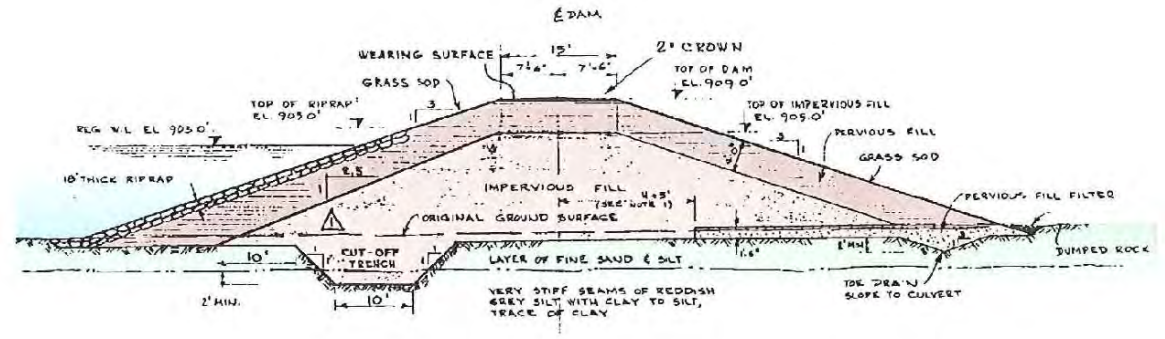
This page intentionally left blank.



Plan



Profile Along Centerline of Culvert

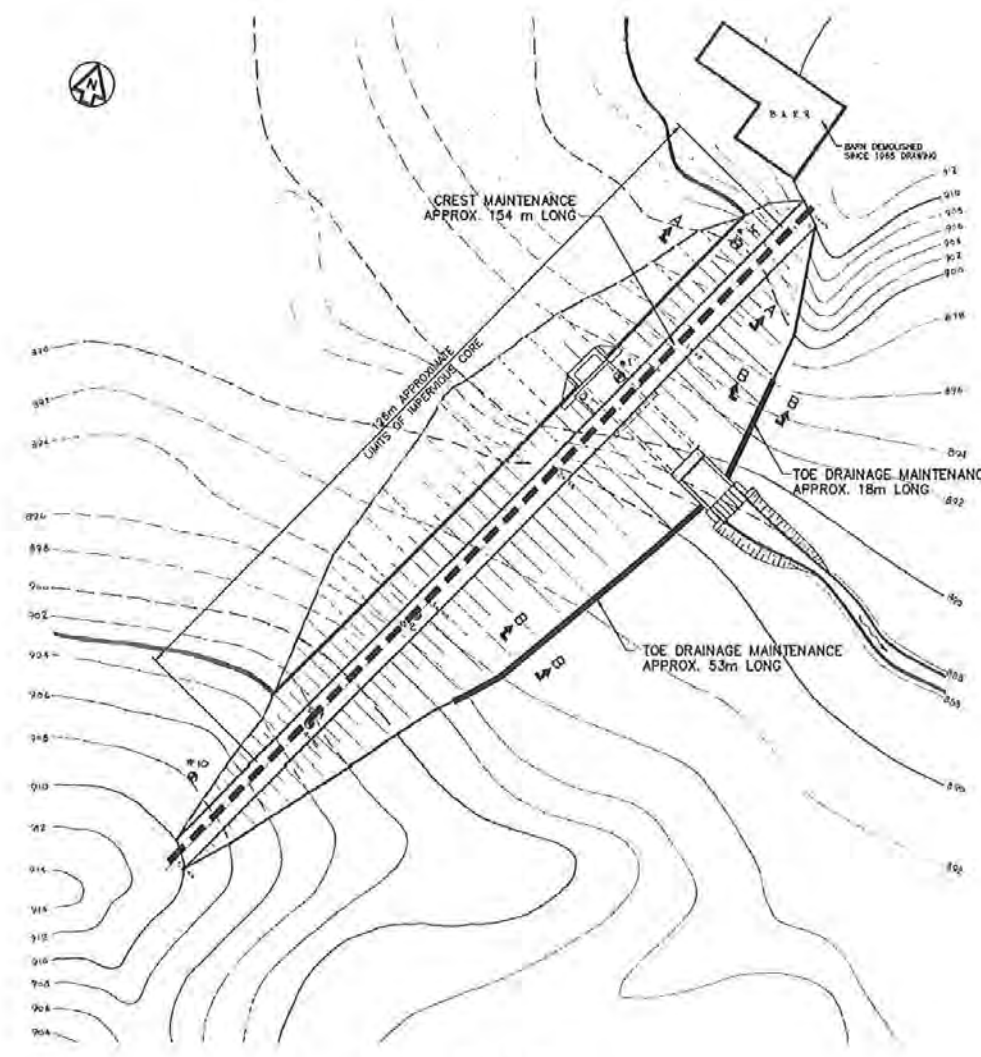


Section B-B

General Arrangement of Valens Reservoir and Dam

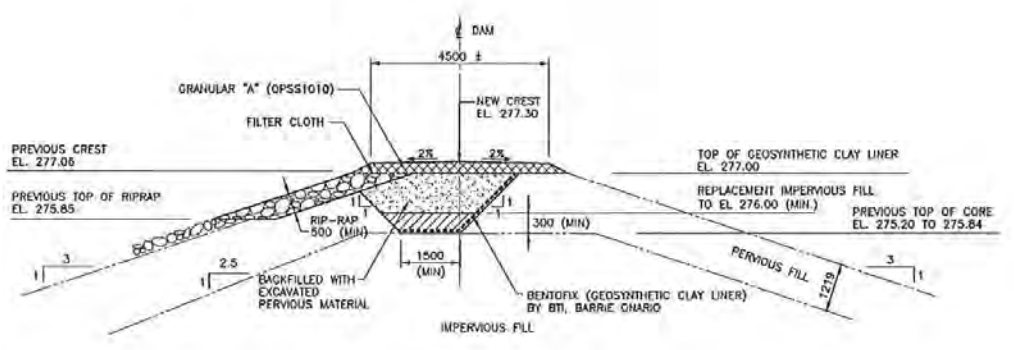
This drawing is copied from as-built drawing DWG. No. 694-A-3.
 R.K. Kilborn & Associates, dated November 1965.
 All units are imperial.

ALL DIMENSIONS ARE IN MILLIMETRES.
ALL ELEVATIONS ARE IN METRES.



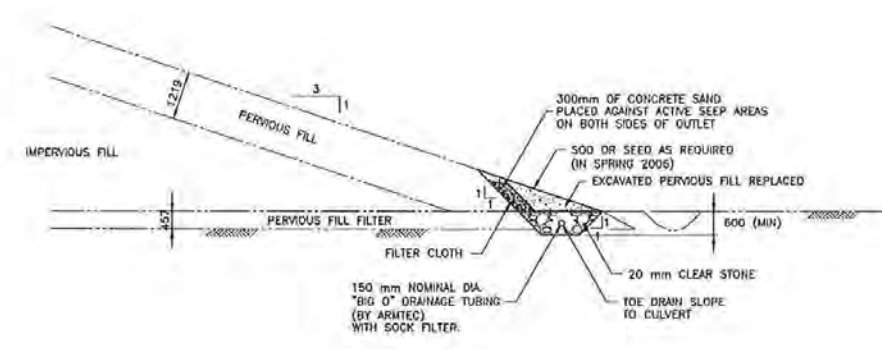
PLAN

DAM - GENERAL ARRANGEMENT
SCALE: 1:500
PLAN AND EXISTING DAM DETAILS FROM AS-BUILT
DWG. NO. 624-A-3, R.K. KILBORN AND ASSOCIATES
NOV. 1985



NOTE:
138.3m OF GEOSYNTHETIC CLAY LINER
WAS INSTALLED ALONG THE CREST

CREST DETAIL SECTION A-A
SCALE: 1:75



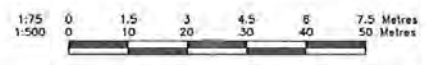
TOE DETAIL SECTION B-B
SCALE: 1:75

FOR AS CONSTRUCTED DAM CROSS SECTIONS
SEE DWG 15816-GT-002



Drawn: S. Graham, 11/2005
 Checked: D. Parkes, 11/2005
 Approved: B.A. MacTavish, 11/2005

DRAWING No. 15816-GT-001



DATE	NO.	ISSUE / REVISION	CH.	APP.	APP.
DEC. 05, 2005	1	ISSUED FOR RECORD		BAM	
AUGUST, 2005	2	ISSUED FOR REVIEW		BAM	

ACRES HAMILTON CONSERVATION AUTHORITY VALENS CONSERVATION AREA, ONTARIO VALENS DAM	
BATCH ACRES DESIGNER: R.D. PEGOS CHECKED: S. GRAHAM CHECKED: D. PARKES	EARTH FILL DAM CREST AND DITCH MAINTENANCE OCTOBER 2005 REPAIRS SHEET 1 OF 2
PROJECT NUMBER: 1581600 PROJECT MANAGER: B.A. MacTAVISH	SCALE: AS SHOWN ACRES PROJECT NO.: 1581600 DRAWING NO.: 15816-GT-001

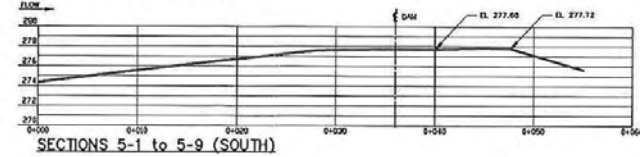
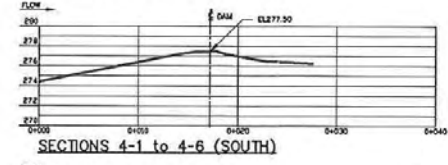
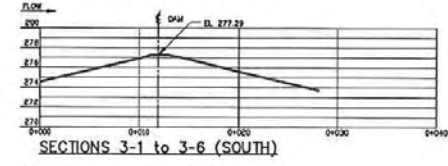
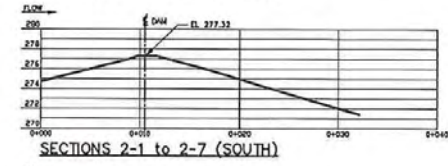
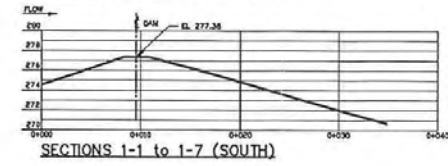
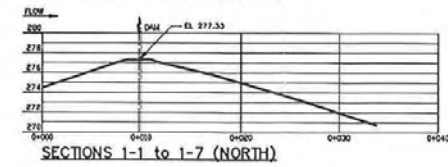
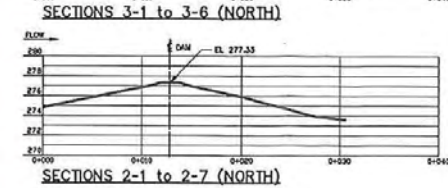
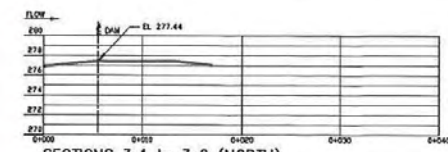
Plot Scale: 1:1
 Dec 26, 2005, 2:50pm
 Drawing Name: 15816-GT-002.dwg



DRAWING No. 15816-GT-002



DAM - AS CONSTRUCTED CROSS SECTION LOCATIONS
 SCALE 1:300



ALL DIMENSIONS ARE IN MILLIMETRES.
 ALL ELEVATIONS ARE IN METRES.

NOTES:

1. BENCHMARK EL. 277.990 LOCATED TOP OF WALL, GATE STRUCTURE UPSTREAM, SOUTH SIDE.
2. SURVEY DATA AND AERIAL IMAGE PROVIDED BY HAMILTON CONSERVATION AUTHORITY AND CITY OF HAMILTON, 2004 AERIAL PHOTOGRAPHY.

ACRES		HAMILTON CONSERVATION AUTHORITY	
VALENS CONSERVATION AREA, ONTARIO		VALENS DAM	
DESIGNED BY	R.D. PEGGS	EARTH FILL DAM CREST AND DITCH MAINTENANCE OCTOBER 2005 REPAIRS AS CONSTRUCTED DAM CROSS SECTIONS	
CHECKED BY	W. McRAE		
DESIGNED BY	D. PARKES		
CHECKED BY	GEORGINE LEAD		
PROJECT ENGINEER	B.A. MacTAVISH	SCALE	AS SHOWN
DATE	DEC. 05, 2005	ACRES PROJECT NO.	1681600
NO.	1	DRAWING NO.	15816-GT-002
ISSUE / REVISION	ISSUED FOR RECORD	REVISION	
CH.	BAM		
APP.	APP.		

This page intentionally left blank.

Valens Dam Data Sheet

Date Completed	1966	
Type of Dam	Earth Fill	
Control	Concrete drop inlet structure	
Purpose	Multi-purpose flood control	
Length	121.90 m	400 feet
Height	6.30 m	20.7 feet
Drainage Area	1090 ha	4.21 sq. miles
25mm Runoff Volume	27.63 ha-m	224 acre-feet
Maximum Storage Volume (906 ft)	203.55 ha-m	1650 acre-feet
Flooded Area at Maximum Storage	109.27 ha	270 acres
Summer Storage Volume (903 ft)	120.90 ha-m	980 acre-feet
Flooded area at Summer Storage	74.87 ha	185 acres
Winter Storage Volume (901 ft)	80.17 ha-m	650 acre-feet
Flooded Area at Winter Storage	29.34 ha	72.5 acres
Summer Flow Augmentation for 100 Days	0.13 m ³ /s	4.6 cfs

Key Elevations	Metric (m) GSC	Imperial (ft) GSC
Crest of Concrete	277.99	912.00
Top of Earth Embankment	277.30	909.78
Crest of Valens Sideroad	276.47	907.00
Maximum Design Flood Reservoir	276.16	906.00
Top of Stoplogs – Summer Level	275.25	903.00
Top of Concrete Drop Inlet Structure	274.64	901.00
Drawdown Winter Level	273.72	898.00
Benchmark on Township Bridge	271.08	889.34
Centre Line of 355mm Low Flow Valve	270.98	889.00
Invert of Low Flow Valve	270.80	888.42

Flow Attenuation (Node 101 & 501, MacLaren, 1990)

Flow Return Period	Flow without Dam m ³ /s	Flow with Dam m ³ /s	Percent Reduction %
2 year	2.28	1.37	39.9
5 year	3.25	1.97	39.4
10 year	3.91	2.31	40.9
20 year	4.54	2.63	42.1
50 year	5.38	3.00	44.2
100 year	6.02	3.27	45.7
Hurricane Hazel	66.19	34.87	47.3

This page intentionally left blank.

APPENDIX B - INUNDATION MAPS

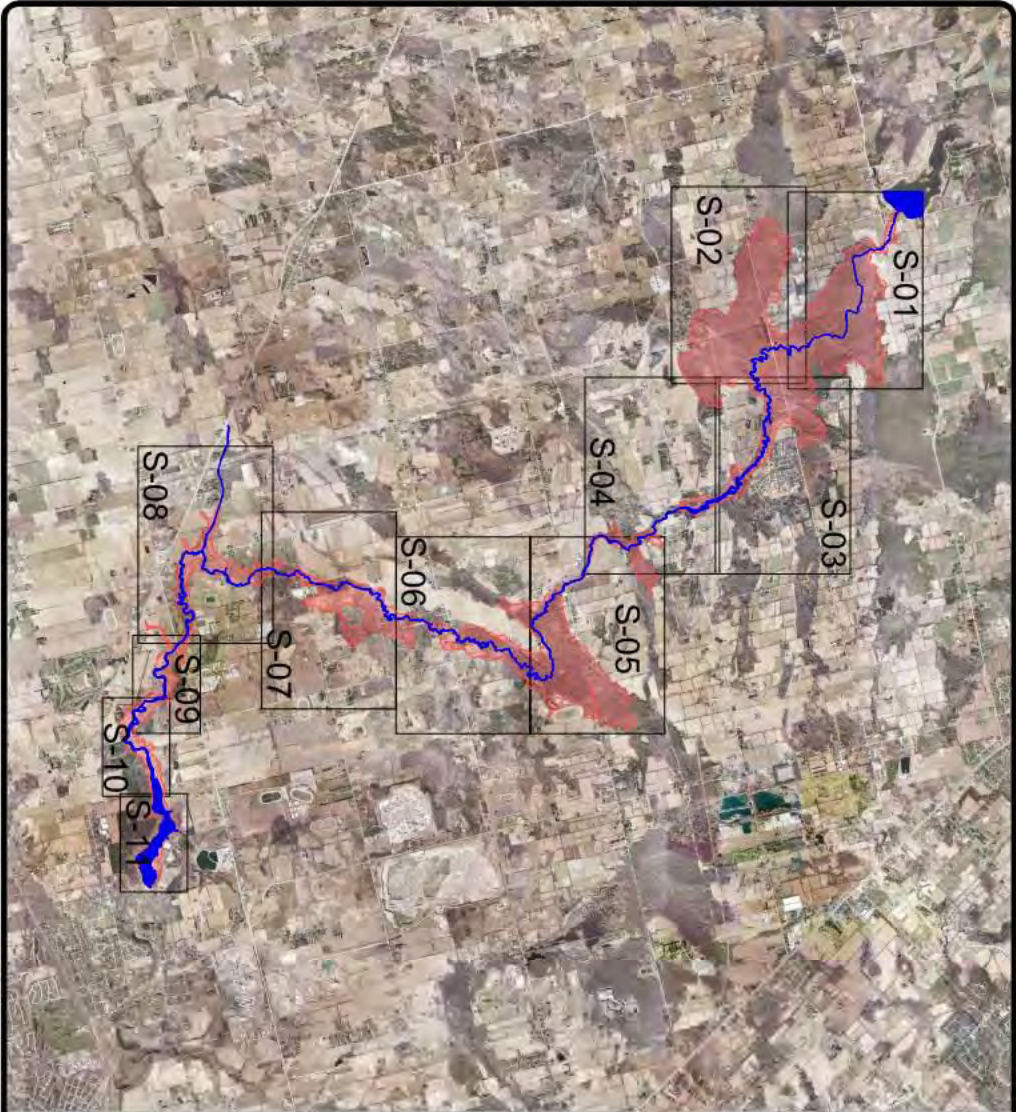


Hamilton
Conservation Authority

LEGEND
 LOCATION OF CROSS SECTION
 NORMAL SUMMER WATER LEVEL
 INUNDATION DUE TO DAM
 FAILURE



The University of Western Australia Inc.



Project:		VALENS DAM	
Title:		DAM BREAK ANALYSIS	
Approved by:		SUNNY DAY CONDITION (GENERAL PLAN)	
Drawn by:	M.B.S.	Date:	JAN. 13/2012
Scale:	1:75000	Project No.:	BRM00601226a
Figure no.:	S-00		

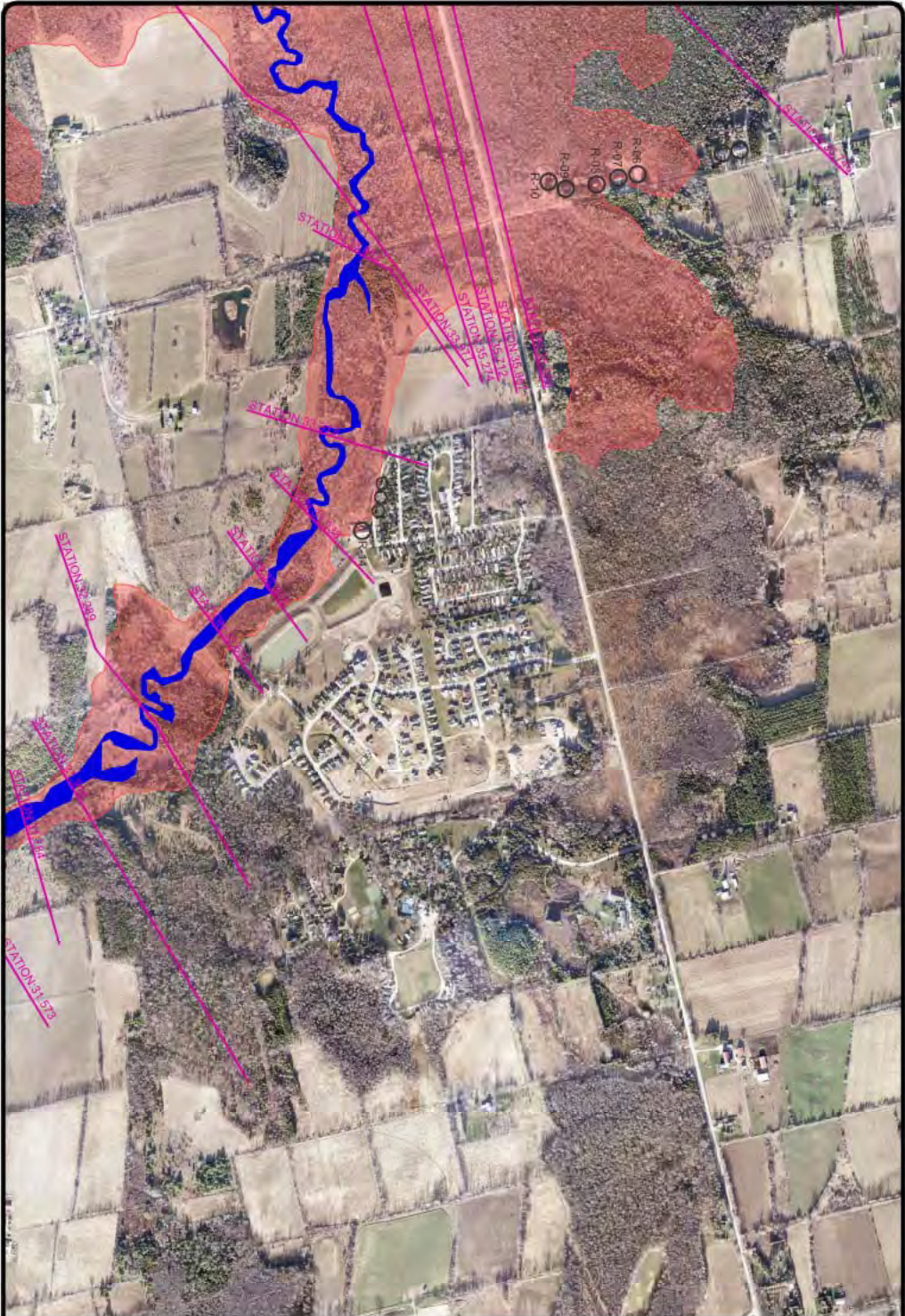


Hamilton
Conservation Authority

- LEGEND**
- LOCATION OF CROSS SECTION
 - NORMAL SUMMER WATER LEVEL
 - INUNDATION DUE TO DAM FAILURE
 - FLOODING AT THE INUNDATION AREA



Project:	VALENS DAM DAM BREAK ANALYSIS		
Title:	SUNNY DAY CONDITION		
Approved by:	S.K.	Date:	JAN. 13/2012
Drawn by:	M.B.S.	Scale:	1:10000
Project No.:	BRM006012266a		
Figure No.:	S-03		



BUILDING	LOWEST ELEVATION (m)	BREACH WATER ELEVATION (m)
3201	286.68	286.38
3202	286.68	286.38
3203	286.50	286.38
3204	286.50	286.38
3205	286.50	286.38
3206	286.50	286.38
3207	286.50	286.38
3208	286.50	286.38
3209	286.50	286.38
3210	286.50	286.38
3211	286.50	286.38
3212	286.50	286.38
3213	286.50	286.38
3214	286.50	286.38
3215	286.50	286.38
3216	286.50	286.38
3217	286.50	286.38
3218	286.50	286.38
3219	286.50	286.38
3220	286.50	286.38
3221	286.50	286.38
3222	286.50	286.38
3223	286.50	286.38
3224	286.50	286.38
3225	286.50	286.38
3226	286.50	286.38
3227	286.50	286.38
3228	286.50	286.38
3229	286.50	286.38
3230	286.50	286.38
3231	286.50	286.38
3232	286.50	286.38
3233	286.50	286.38
3234	286.50	286.38
3235	286.50	286.38
3236	286.50	286.38
3237	286.50	286.38
3238	286.50	286.38
3239	286.50	286.38
3240	286.50	286.38
3241	286.50	286.38
3242	286.50	286.38
3243	286.50	286.38
3244	286.50	286.38
3245	286.50	286.38
3246	286.50	286.38
3247	286.50	286.38
3248	286.50	286.38
3249	286.50	286.38
3250	286.50	286.38
3251	286.50	286.38
3252	286.50	286.38
3253	286.50	286.38
3254	286.50	286.38
3255	286.50	286.38
3256	286.50	286.38
3257	286.50	286.38
3258	286.50	286.38
3259	286.50	286.38
3260	286.50	286.38
3261	286.50	286.38
3262	286.50	286.38
3263	286.50	286.38
3264	286.50	286.38
3265	286.50	286.38
3266	286.50	286.38
3267	286.50	286.38
3268	286.50	286.38
3269	286.50	286.38
3270	286.50	286.38
3271	286.50	286.38
3272	286.50	286.38
3273	286.50	286.38
3274	286.50	286.38
3275	286.50	286.38
3276	286.50	286.38
3277	286.50	286.38
3278	286.50	286.38
3279	286.50	286.38
3280	286.50	286.38
3281	286.50	286.38
3282	286.50	286.38
3283	286.50	286.38
3284	286.50	286.38
3285	286.50	286.38
3286	286.50	286.38
3287	286.50	286.38
3288	286.50	286.38
3289	286.50	286.38
3290	286.50	286.38
3291	286.50	286.38
3292	286.50	286.38
3293	286.50	286.38
3294	286.50	286.38
3295	286.50	286.38
3296	286.50	286.38
3297	286.50	286.38
3298	286.50	286.38
3299	286.50	286.38
3300	286.50	286.38



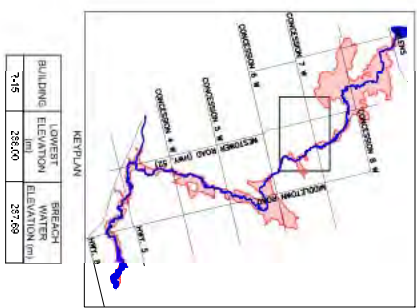
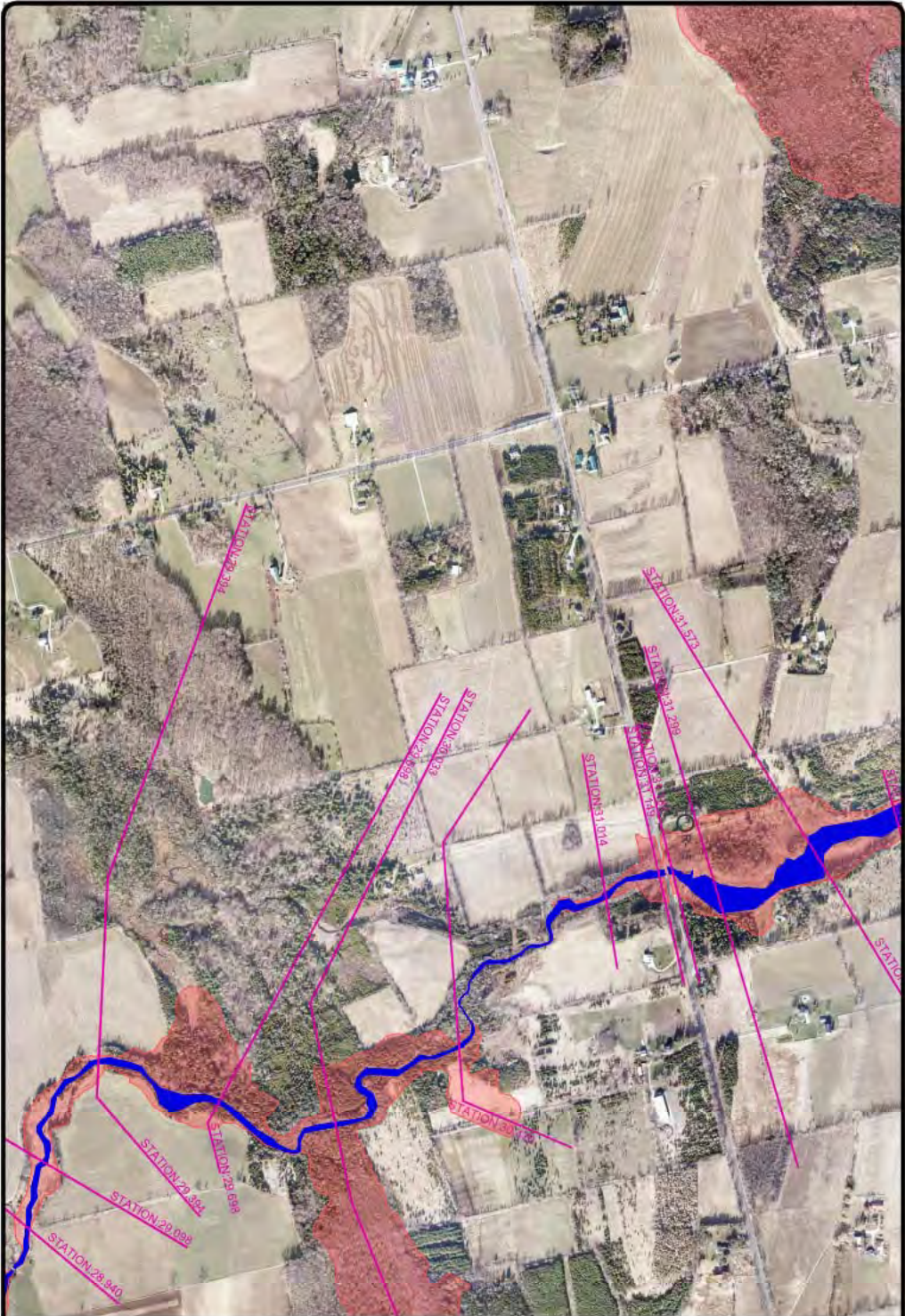


Hamilton
Conservation Authority

- LEGEND**
- LOCATION OF CROSS SECTION
 - NORMAL SUMMER WATER LEVEL
 - FAILURE DUE TO DAM
 - FAILURE
 - FAILURE WITHIN FAILURE AREA



Project:	VALENS DAM		
Title:	DAM BREAK ANALYSIS		
Approved by:	S.K.	Date:	JAN. 13/2012
Drawn by:	M.B.S.	Scale:	1:10000
Project No.:	BRM006012266		
Figure No.:	S-04		



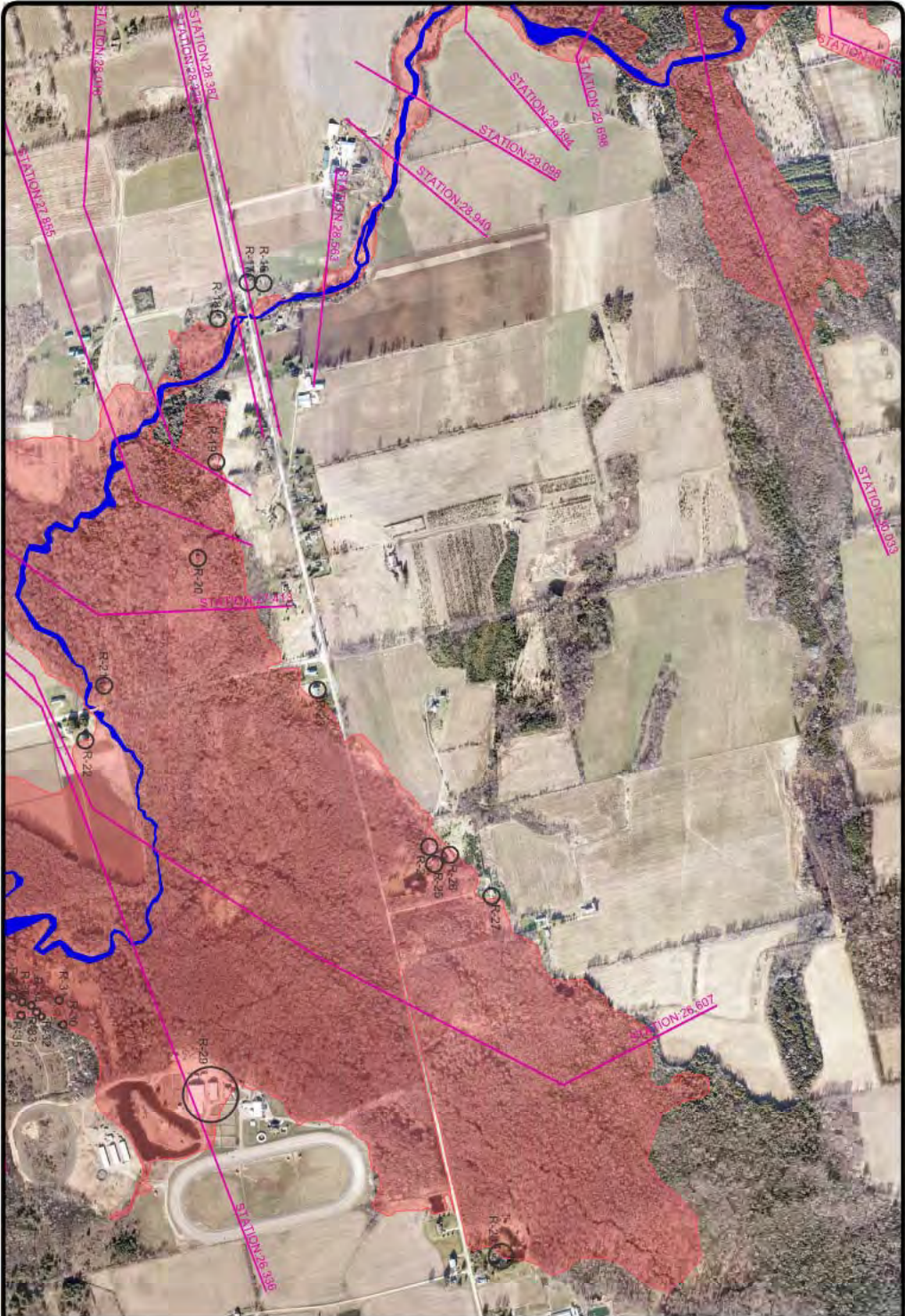


Hamilton Conservation Authority

- LEGEND**
- 1 LOCATION OF CROSS SECTION
 - 2 NORMAL SUMMER WATER LEVEL
 - 3 UNLAKED DUE TO DAM
 - 4 FAILING
 - 5 9400 FLOODING AT THE MILLS/STATION AREA



Project:		VALENS DAM	
Title:		DAM BREAK ANALYSIS	
Approved by:		S.K.	
Date:		JAN. 13/2012	
Drawn by:		M.B.S.	
Scale:		1:10000	
Project No.:		BRM006012266a	
Figure no.:		S-05	



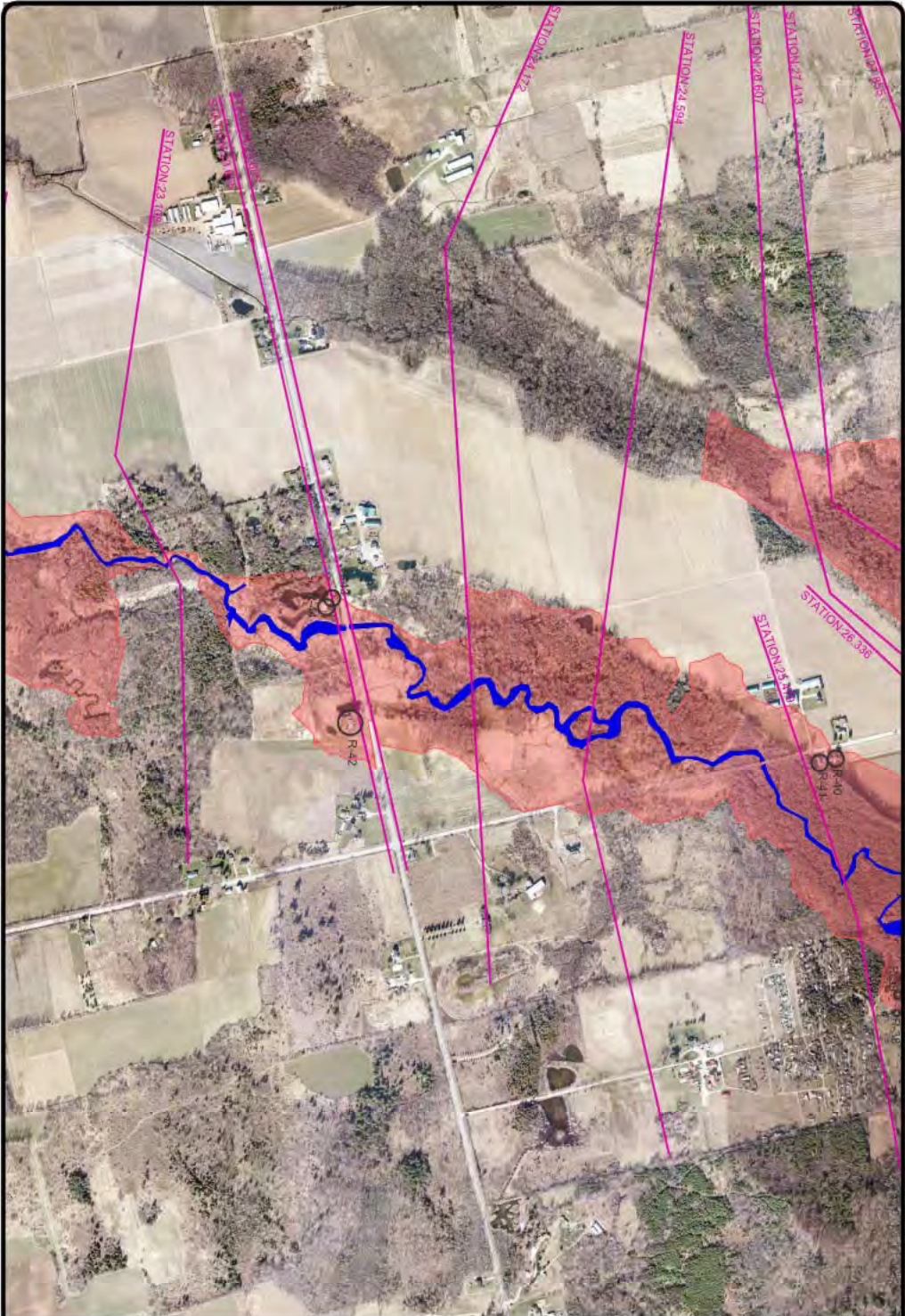
BUILDING	LOWEST ELEVATION (m)	BREACH WATER ELEVATION (m)
R-16	249.728	249.728
R-17	252.500	252.500
R-18	252.500	252.500
R-19	250.000	250.000
R-20	248.000	248.000
R-21	248.000	248.000
R-22	248.000	248.000
R-23	248.000	248.000
R-24	248.000	248.000
R-25	248.000	248.000
R-26	248.000	248.000
R-27	248.000	248.000
R-28	248.000	248.000
R-29	248.000	248.000
R-30	248.000	248.000
R-31	248.000	248.000
R-32	248.000	248.000
R-33	248.000	248.000
R-34	248.000	248.000
R-35	248.000	248.000
R-36	248.000	248.000
R-37	248.000	248.000





**Hamilton
Conservation Authority**

- LEGEND**
- LOCATION OF CROSS SECTION
 - NORMAL SUMMER WATER LEVEL
 - FAILURE DUE TO DAM
 - FAILURE
 - FAILURE WITHIN INUNDATION AREA



BUILDING	LOWEST ELEVATION (m)	HIGHEST ELEVATION (m)	BREACH WATER ELEVATION (m)
2-38	218.24	218.71	218.71
2-39	218.00	218.41	218.41
2-40	218.00	218.41	218.41
2-41	218.00	218.41	218.41
2-42	218.00	218.02	218.02
2-43	218.27	218.00	218.00
2-44	218.51	218.00	218.00



Project: **VALENS DAM
DAM BREAK ANALYSIS**

Title: **SUNNY DAY CONDITION**

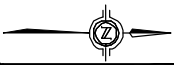
Approved by: **S.K.** Date: **JAN. 13/2012** Project No.: **BRM00601226a**

Drawn by: **M.B.S.** Scale: **1:10000** Figure no.: **S-06**

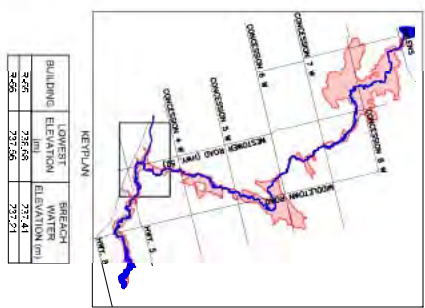
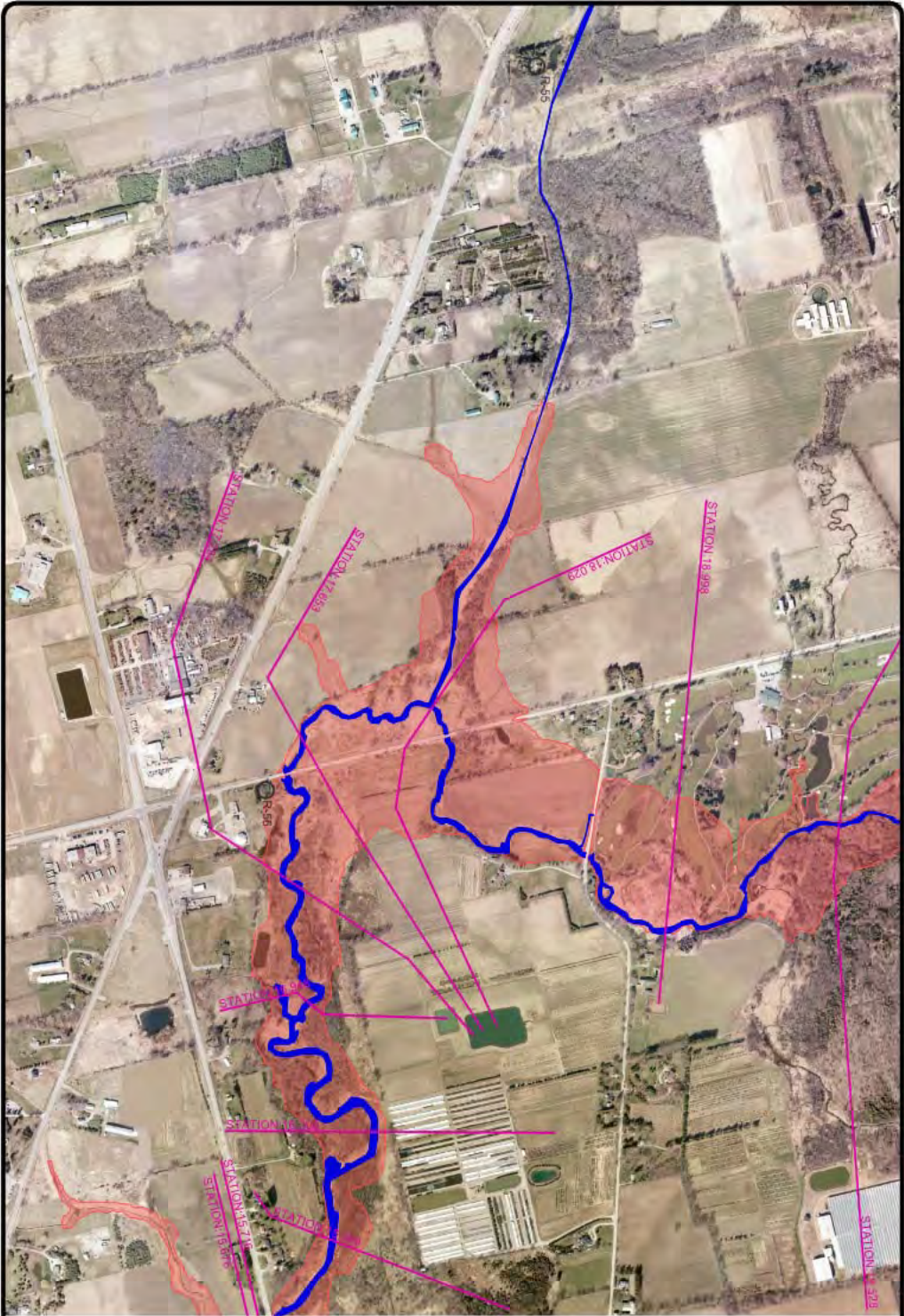


**Hamilton
Conservation Authority**

- LEGEND**
- LOCATION OF CROSS SECTION
 - █ NORMAL SUMMER WATER LEVEL
 - █ INUNDATION DUE TO DAM FAILURE
 - █ FAILING AREA
 - █ 900 FEETING WITHIN INUNDATION AREA



Project:		VALENS DAM	
Title:		DAM BREAK ANALYSIS	
Approved by:		S.K.	
Date:		JAN. 13/2012	
Drawn by:		M.B.S.	
Scale:		1:10000	
Project no.:		BRM006012266	
Figure no.:		S-08	

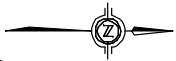


CONCRETE	BUILDING ELEVATION (m)	BREACH WATER ELEVATION (m)
1	225.00	212.41
2	225.00	212.41
3	225.00	212.41
4	225.00	212.41
5	225.00	212.41
6	225.00	212.41
7	225.00	212.41
8	225.00	212.41
9	225.00	212.41
10	225.00	212.41
11	225.00	212.41
12	225.00	212.41
13	225.00	212.41
14	225.00	212.41
15	225.00	212.41
16	225.00	212.41
17	225.00	212.41
18	225.00	212.41
19	225.00	212.41
20	225.00	212.41
21	225.00	212.41
22	225.00	212.41
23	225.00	212.41
24	225.00	212.41
25	225.00	212.41
26	225.00	212.41
27	225.00	212.41
28	225.00	212.41
29	225.00	212.41
30	225.00	212.41
31	225.00	212.41
32	225.00	212.41
33	225.00	212.41
34	225.00	212.41
35	225.00	212.41
36	225.00	212.41
37	225.00	212.41
38	225.00	212.41
39	225.00	212.41
40	225.00	212.41
41	225.00	212.41
42	225.00	212.41
43	225.00	212.41
44	225.00	212.41
45	225.00	212.41
46	225.00	212.41
47	225.00	212.41
48	225.00	212.41
49	225.00	212.41
50	225.00	212.41
51	225.00	212.41
52	225.00	212.41
53	225.00	212.41
54	225.00	212.41
55	225.00	212.41
56	225.00	212.41
57	225.00	212.41
58	225.00	212.41
59	225.00	212.41
60	225.00	212.41
61	225.00	212.41
62	225.00	212.41
63	225.00	212.41
64	225.00	212.41
65	225.00	212.41
66	225.00	212.41
67	225.00	212.41
68	225.00	212.41
69	225.00	212.41
70	225.00	212.41
71	225.00	212.41
72	225.00	212.41
73	225.00	212.41
74	225.00	212.41
75	225.00	212.41
76	225.00	212.41
77	225.00	212.41
78	225.00	212.41
79	225.00	212.41
80	225.00	212.41
81	225.00	212.41
82	225.00	212.41
83	225.00	212.41
84	225.00	212.41
85	225.00	212.41
86	225.00	212.41
87	225.00	212.41
88	225.00	212.41
89	225.00	212.41
90	225.00	212.41
91	225.00	212.41
92	225.00	212.41
93	225.00	212.41
94	225.00	212.41
95	225.00	212.41
96	225.00	212.41
97	225.00	212.41
98	225.00	212.41
99	225.00	212.41
100	225.00	212.41

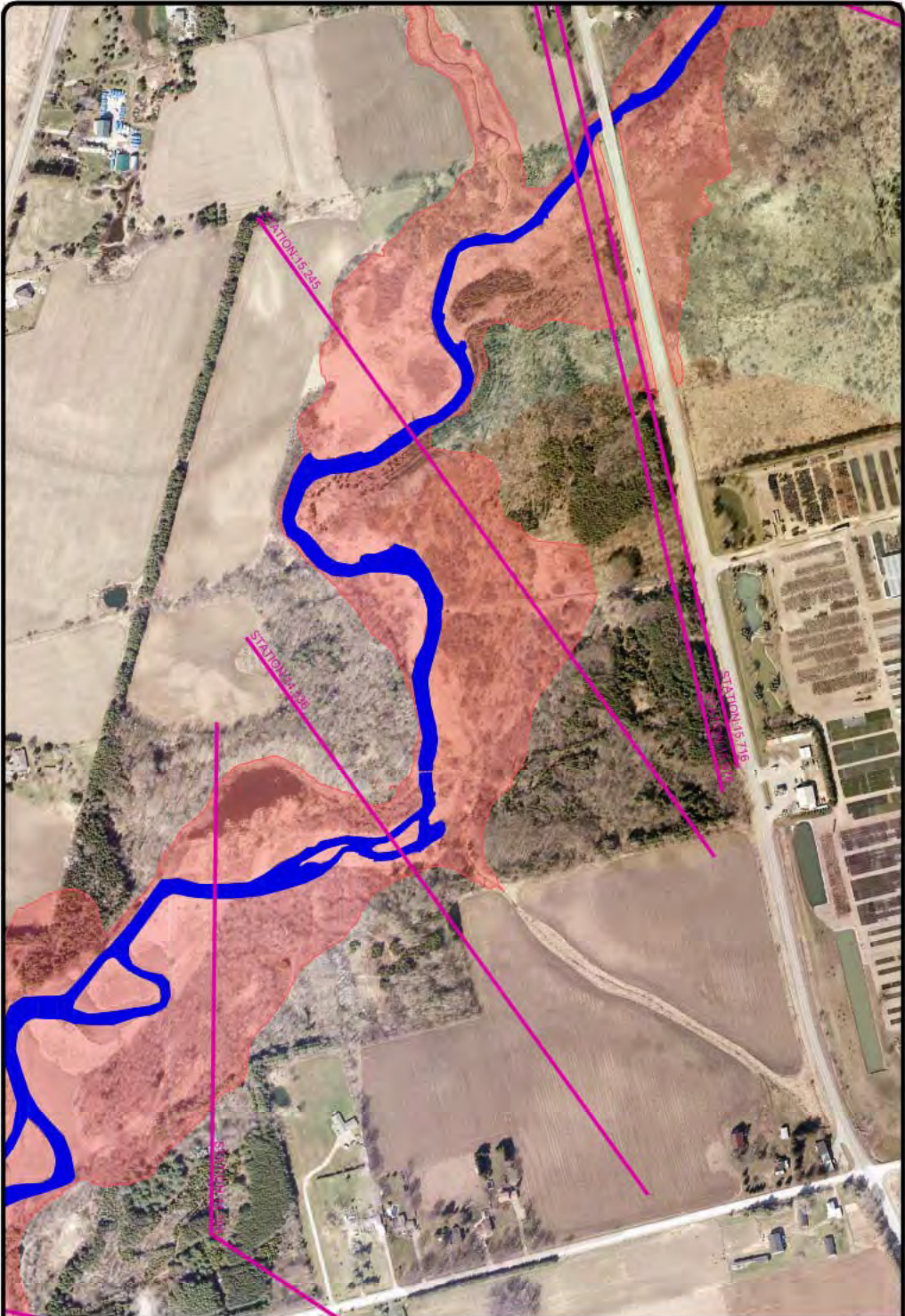


Hamilton
Conservation Authority

- LEGEND**
- LOCATION OF CROSS SECTION
 - NORMAL SUMMER WATER LEVEL
 - FAILURE DUE TO DAM FAILURE
 - FAILURE DUE TO DAM FAILURE
 - FAILURE DUE TO DAM FAILURE



Project:		VALENS DAM	
Title:		DAM BREAK ANALYSIS	
Approved by:		S.K.	
Date:		JAN. 13/2012	
Drawn by:		M.B.S.	
Scale:		1:5000	
Project No.:		BRM00601226a	
Figure No.:		S-09	



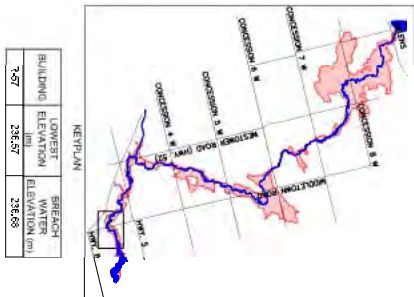
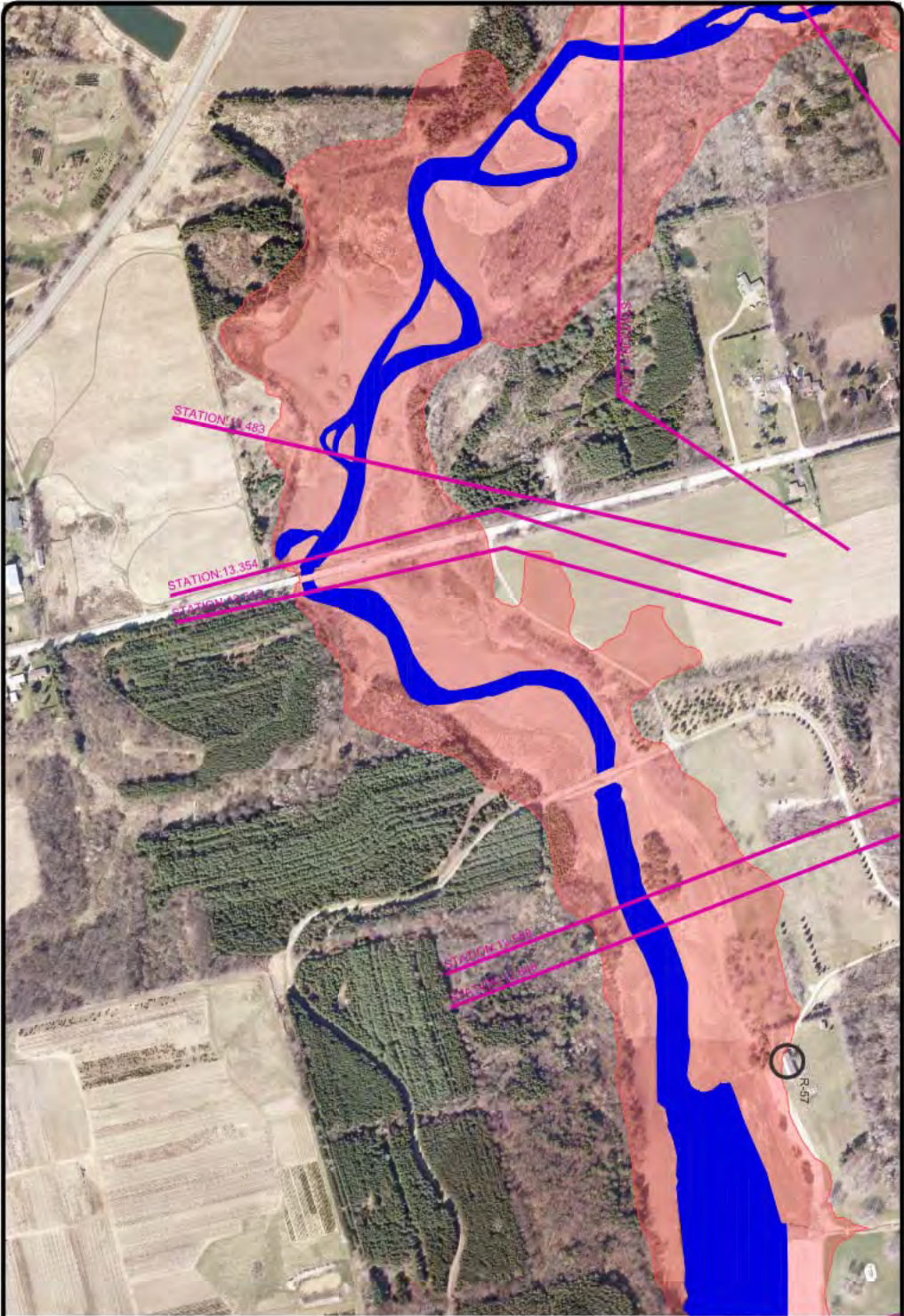


Hamilton
Conservation Authority

- LEGEND**
- LOCATION OF CROSS SECTION
 - NORMAL SUMMER WATER LEVEL
 - INUNDATION DUE TO DAM FAILURE
 - RAILROADS WITHIN JURISDICTION



Project:		VALENS DAM	
Title:		DAM BREAK ANALYSIS	
Approved by:		S.K.	
Date:		JAN. 13/2012	
Drawn by:		M.B.S.	
Scale:		1:5000	
Project no.:		BRM00601226a	
Figure no.:		S-10	



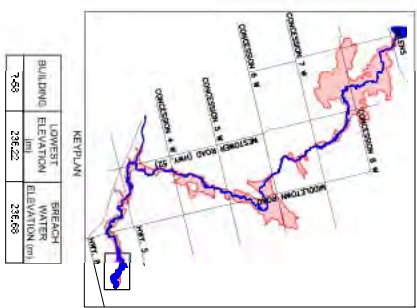
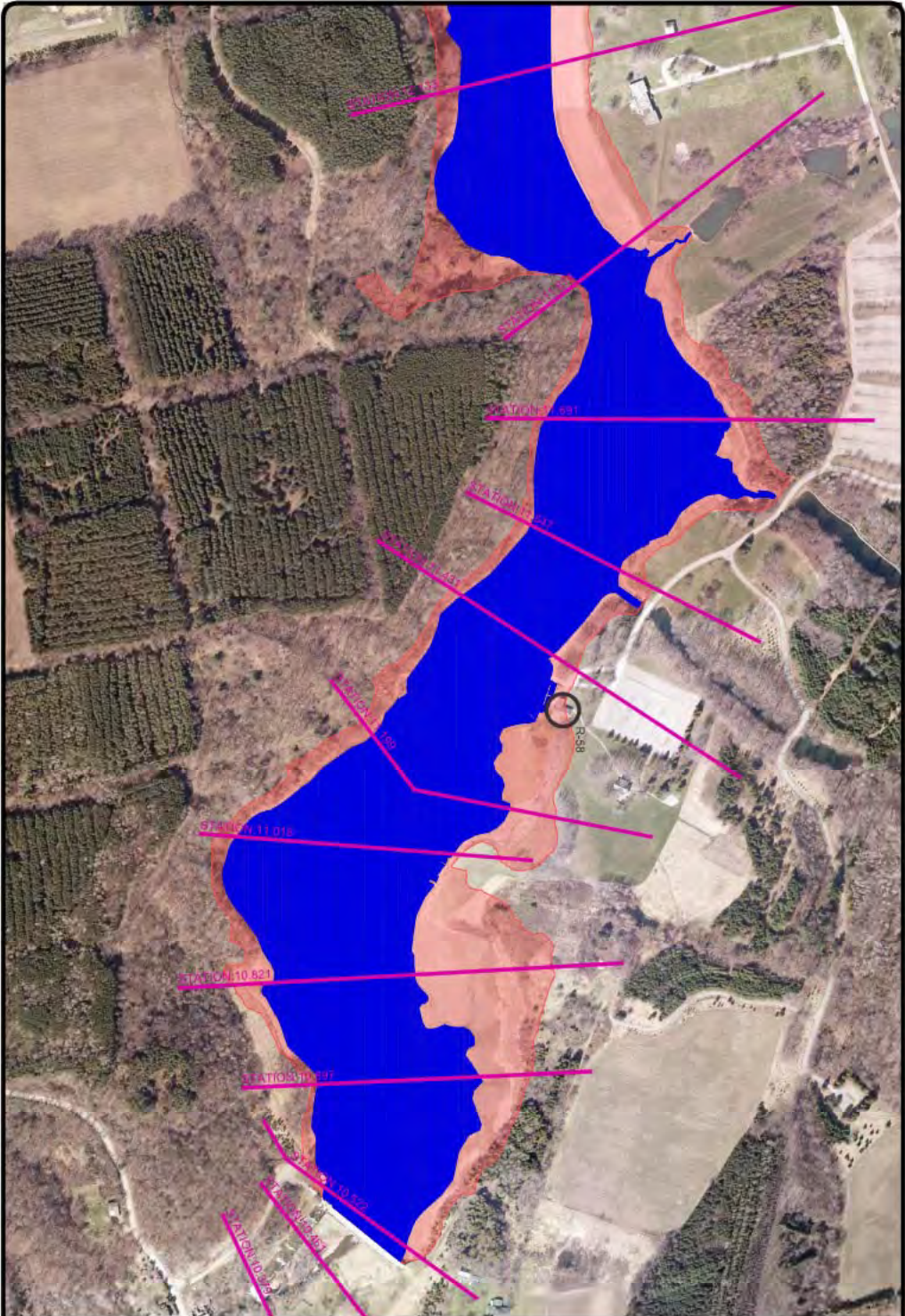


Hamilton
Conservation Authority

- LEGEND**
- █ LOCATION OF FENCE SECTION
 - █ NORMAL SUMMER WATER LEVEL
 - █ INUNDATION DUE TO DAM FAILURE
 - █ FAILURE
 - █ BUILDINGS AT RISK OF INUNDATION



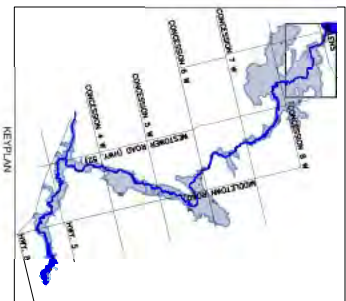
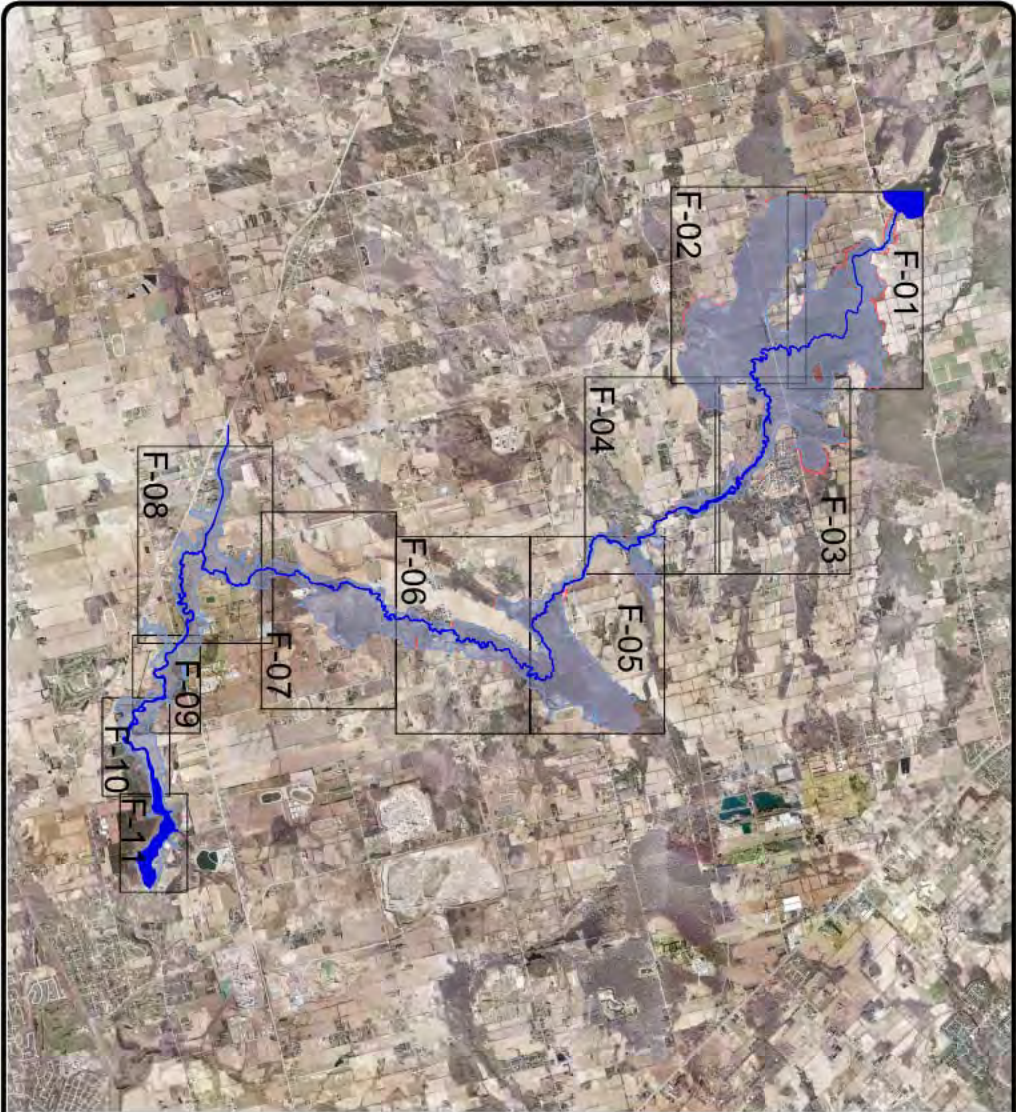
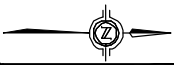
Project:		VALENS DAM	
Title:		DAM BREAK ANALYSIS	
Approved by:		S.K.	
Date:		JAN. 13/2012	
Drawn by:		M.B.S.	
Scale:		1:5000	
Project No.:		BRM00601226a	
Figure no.:		S-11	





Hamilton
Conservation Authority

- LEGEND**
- █ LOCATION OF CROSS SECTION
 - █ NORMAL SUMMER WATER LEVEL
 - █ INUNDATION DUE TO DAM FAILURE
 - █ 10% INUNDATION



Project:

Title		Project No.	
VALENS DAM DAM BREAK ANALYSIS INFLOW DESIGN FLOOD CONDITION (GENERAL PLAN)		BRM00601226a	
Approved by:	Date	Drawn by:	Scale
S.K.	JAN. 13/2012	M.B.S.	1:75000
Figure no.:			F-00



**Hamilton
Conservation Authority**

- LEGEND**
- LOCATION OF CROSS SECTION
 - NORMAL SUMMER WATER LEVEL
 - INUNDATION DUE TO DAM FAILURE
 - 10% INUNDATION
 - BUILDING WITHIN INUNDATION AREA



BUILDING	FOREST	OPEN WATER	WATER
ELEVATION (m)	ELEVATION (m)	ELEVATION (m)	ELEVATION (m)
R-01	272.61	271.73	272.73



Project:		VALSENS DAM	
Title:		DAM BREAK ANALYSIS	
Approved by:		S.K.	
Date:		JAN. 13/2012	
Project No.:		BRM00601226a	
Drawn by:		M.B.S.	
Scale:		1:10000	
Figure no.:		F-01	

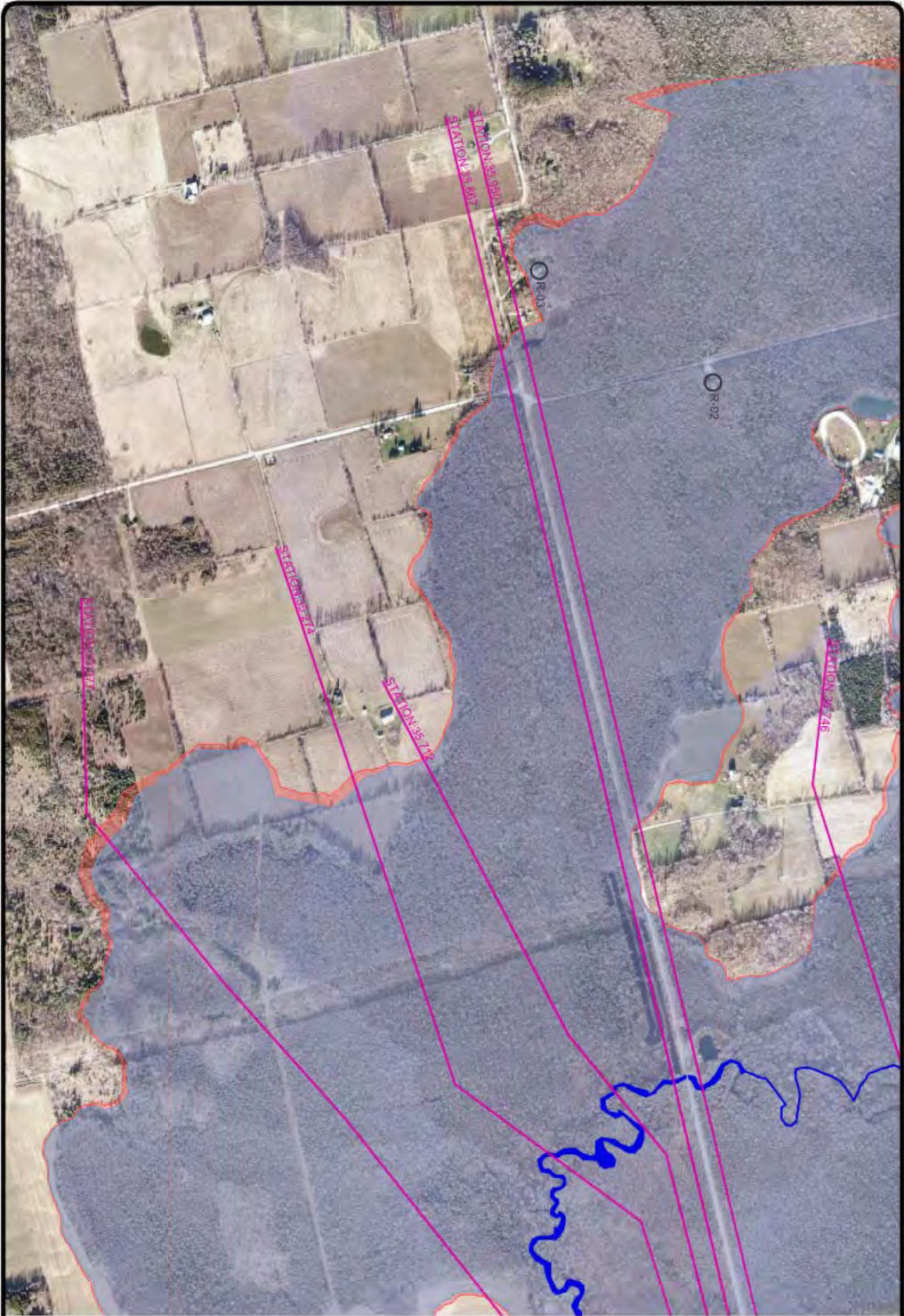


**Hamilton
Conservation Authority**

- LEGEND**
- LOCATION OF FLOOD SECTION
 - NORMAL SUMMER WATER LEVEL
 - INUNDATION DUE TO DAM FAILURE
 - 17% INUNDATION
 - BUILDING WITH INUNDATION
 - 40% AREA



Project:		VALENS DAM	
Title:		DAM BREAK ANALYSIS	
Approved by:		S.K.	
Date:		JAN. 13/2012	
Drawn by:		M.B.S.	
Scale:		1:10000	
Project No.:		BRM00601226a	
Figure No.:		F-02	



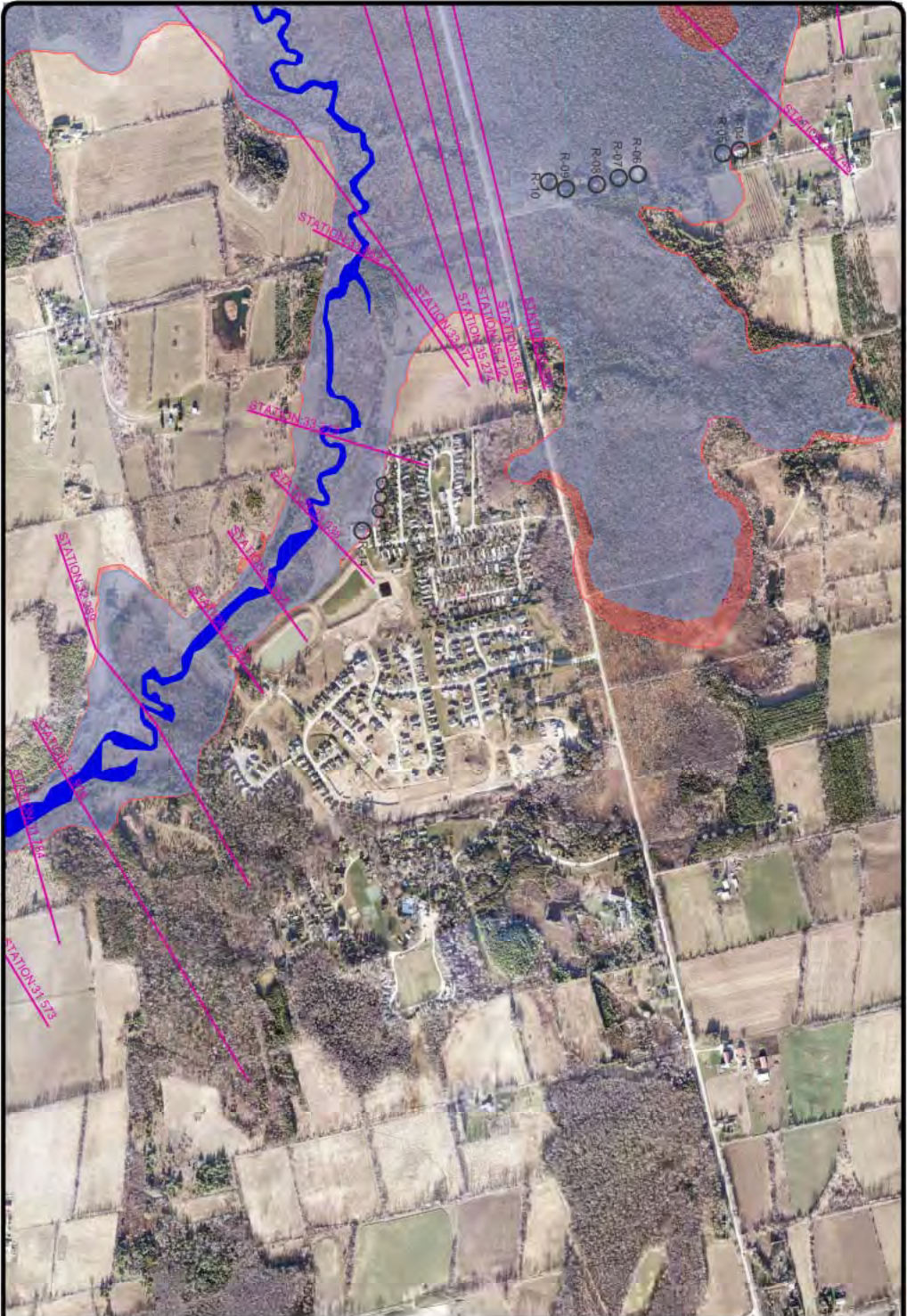
CONCRETE	REF. WATER	BRICK
BUILDING ELEVATION (m)	ELEVATION (m)	WATER ELEVATION (m)
R-02	208.00	208.00
R-03	210.00	208.00





Hamilton
Conservation Authority

- LEGEND**
- LOCATION OF FLOOD SECTION
 - NORMAL SUMMER WATER LEVEL
 - INUNDATION DUE TO DAM FAILURE
 - 10% INUNDATION
 - BUILDING WITHIN INUNDATION AREA



BUILDING	TOWNSHIP	LOWEST ELEVATION (m)	SPRING WATER ELEVATION (m)	WATER ELEVATION (m)
R-406	VALSENS	267.22	267.67	267.67
R-407	VALSENS	268.77	269.22	269.22
R-408	VALSENS	269.77	270.22	270.22
R-409	VALSENS	270.77	271.22	271.22
R-410	VALSENS	271.77	272.22	272.22
R-411	VALSENS	272.77	273.22	273.22
R-412	VALSENS	273.77	274.22	274.22
R-413	VALSENS	274.77	275.22	275.22
R-414	VALSENS	275.77	276.22	276.22



Project:		Title:	
VALSENS DAM		INFLOW DESIGN FLOOD CONDITION	
DAM BREAK ANALYSIS			
Accounted by:	S.K.	Date:	JAN. 13/2012
Drawn by:	M.B.S.	Scale:	1:10000
Project No.:		Project No.:	
BRM006012266a		BRM006012266a	
Figure No.:		Figure No.:	
F-03		F-03	

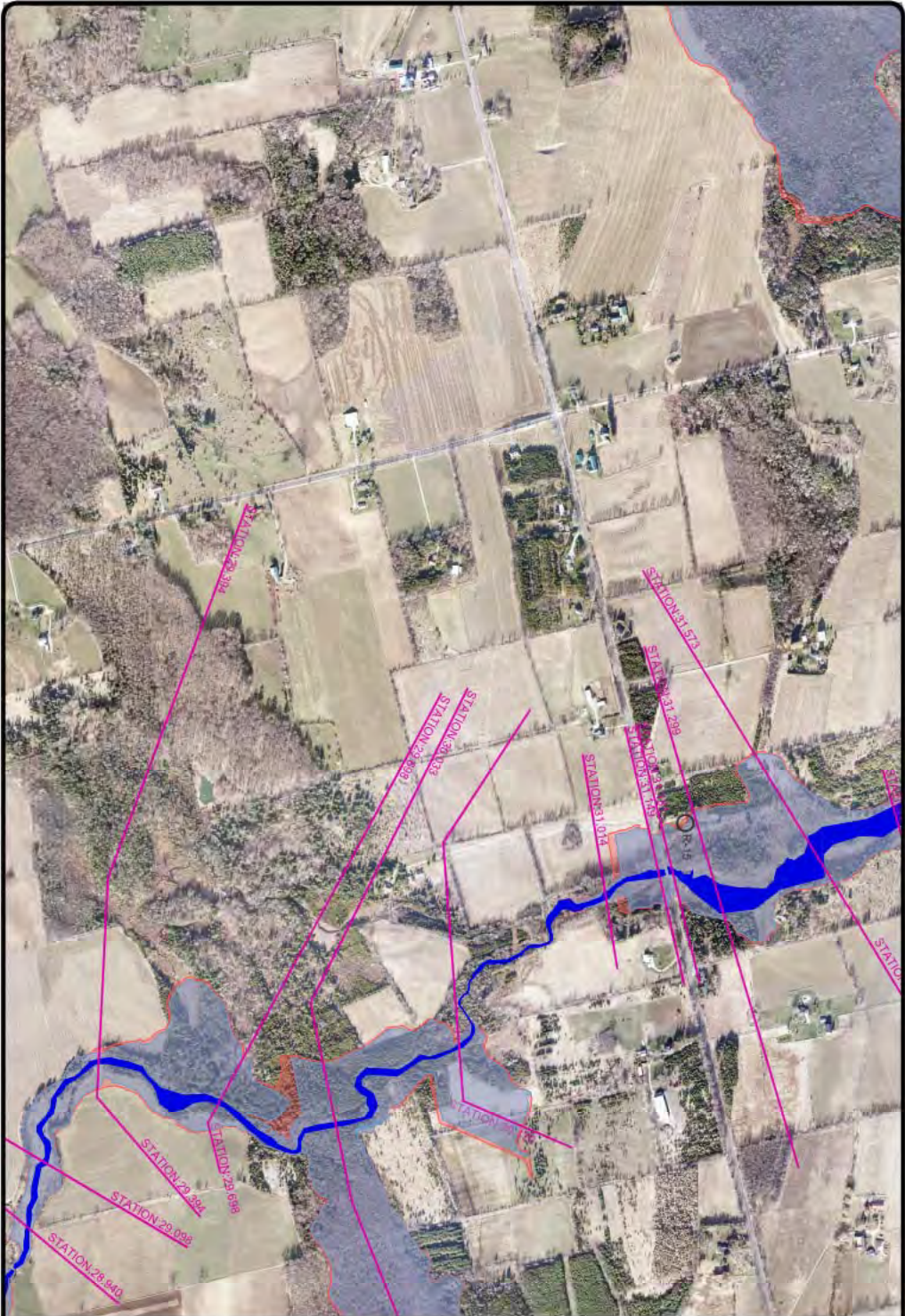


**Hamilton
Conservation Authority**

- LEGEND**
- LOCATION OF FLOOD SECTION
 - █ NORMAL SUMMER WATER LEVEL
 - █ INUNDATION DUE TO DAM
 - █ FAILURE
 - █ 17% INUNDATION
 - █ BUILDING WITH INUNDATION
 - █ AREA



Project:		VALENS DAM	
Title:		DAM BREAK ANALYSIS	
Approved by:		INFLOW DESIGN FLOOD CONDITION	
Drawn by:	M.B.S.	Date:	JAN. 13/2012
Scale:	1:10000	Project No.:	BRM006012266
Figure no.:		F-04	



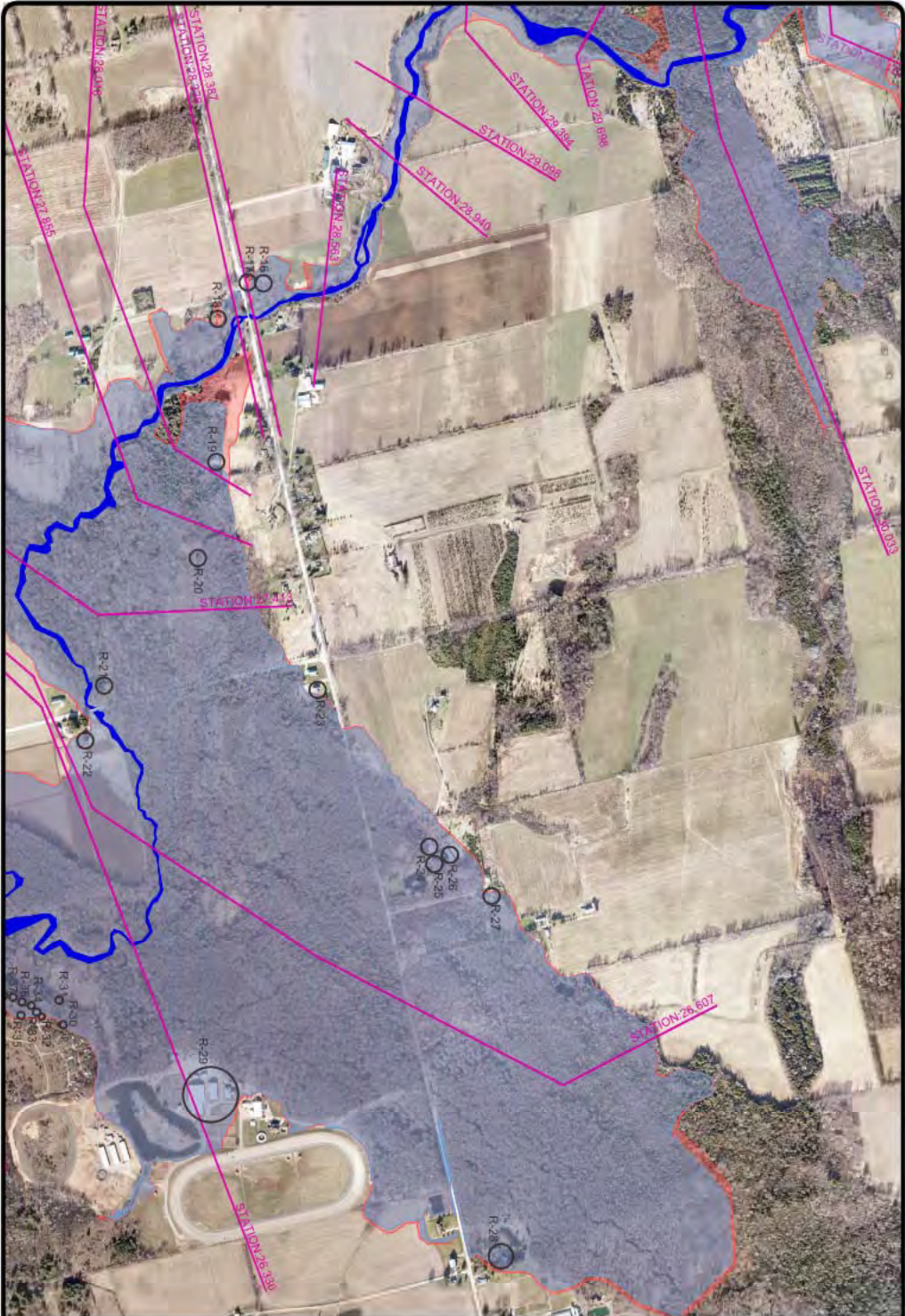
CONCEPT	CONCEPT	CONCEPT
BUILDING ELEVATION (m)	FOREST ELEVATION (m)	SPRINKLER WATER ELEVATION (m)
R-15	2520	2627





Hamilton Conservation Authority

- LEGEND**
- LOCATION OF CROSS SECTION
 - NORMAL SUMMER WATER LEVEL
 - INUNDATION DUE TO DAM FAILURE
 - 100 YEAR FLOOD
 - BUILDING WITH INUNDATION AREA



BUILDING	FOREST ELEVATION (m)	SPRINKLER ELEVATION (m)	BREACH WATER ELEVATION (m)
R-16	262.79	255.08	255.29
R-17	262.79	255.08	255.29
R-18	262.79	255.08	255.29
R-19	262.79	255.08	255.29
R-20	262.79	255.08	255.29
R-21	262.79	255.08	255.29
R-22	262.79	255.08	255.29
R-23	262.79	255.08	255.29
R-24	262.79	255.08	255.29
R-25	262.79	255.08	255.29
R-26	262.79	255.08	255.29
R-27	262.79	255.08	255.29
R-28	262.79	255.08	255.29
R-29	262.79	255.08	255.29
R-30	262.79	255.08	255.29
R-31	262.79	255.08	255.29
R-32	262.79	255.08	255.29
R-33	262.79	255.08	255.29
R-34	262.79	255.08	255.29
R-35	262.79	255.08	255.29
R-36	262.79	255.08	255.29
R-37	262.79	255.08	255.29



Project: **VALENS DAM DAM BREAK ANALYSIS**

Title: **INFLOW DESIGN FLOOD CONDITION**

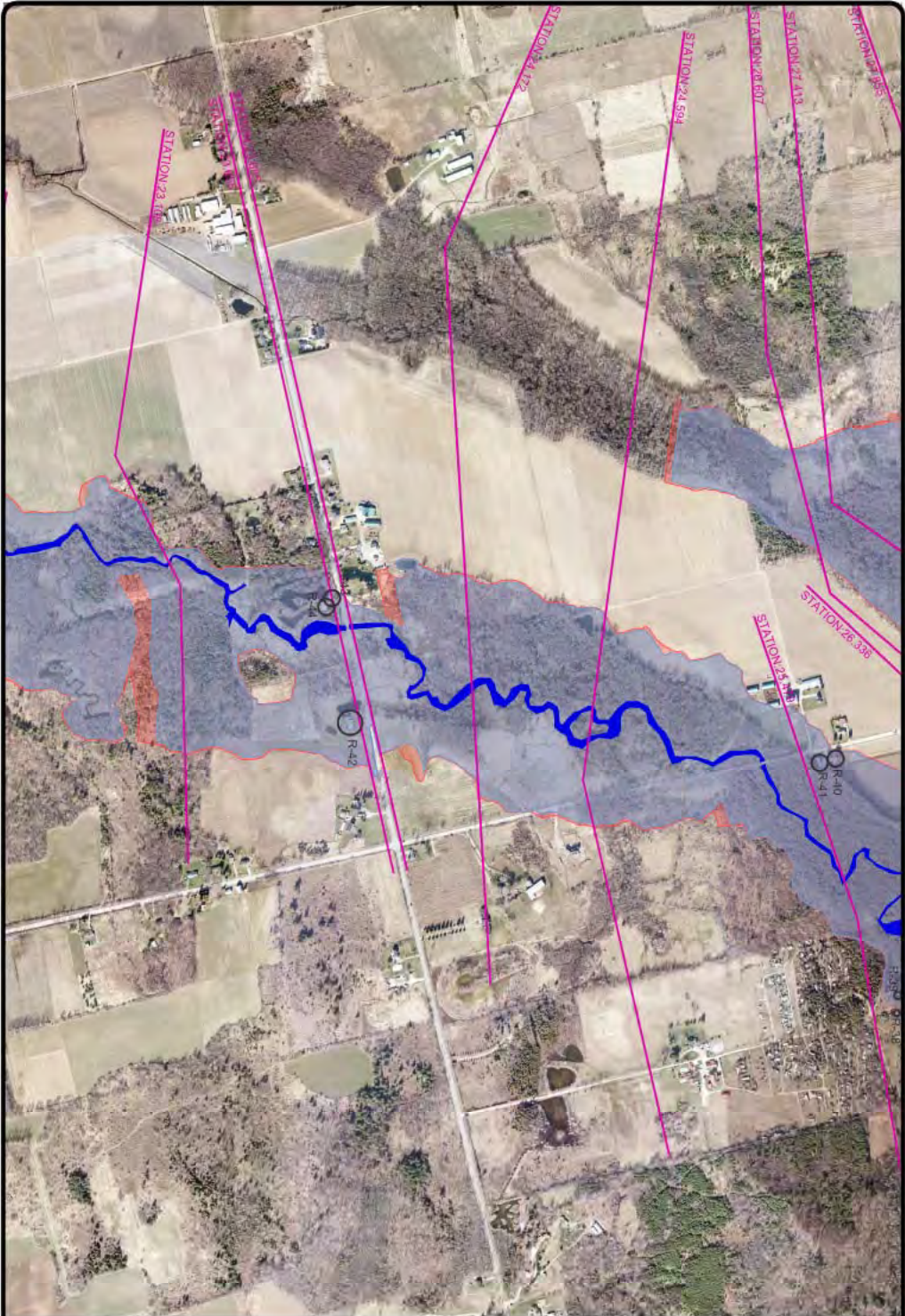
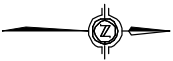
Approved by: **S.K.** Date: **JAN. 13/2012** Project No.: **BRM00601226a**

Drawn by: **M.B.S.** Scale: **1:10000** Figure no.: **F-05**



**Hamilton
Conservation Authority**

- LEGEND**
- █ LOCATION OF FENCE SECTION
 - █ NORMAL SUMMER WATER LEVEL
 - █ INUNDATION DUE TO DAM FAILURE
 - █ 10% INUNDATION
 - █ BUILDING WITHIN INUNDATION AREA



Project:		VALENS DAM	
Title:		DAM BREAK ANALYSIS	
INFLOW DESIGN FLOOD CONDITION			
Approved by:	S.K.	Date:	JAN. 13/2012
Drawn by:	M.B.S.	Scale:	1:10000
Project No.:		BRM006012266	
Drawing No.:		F-06	



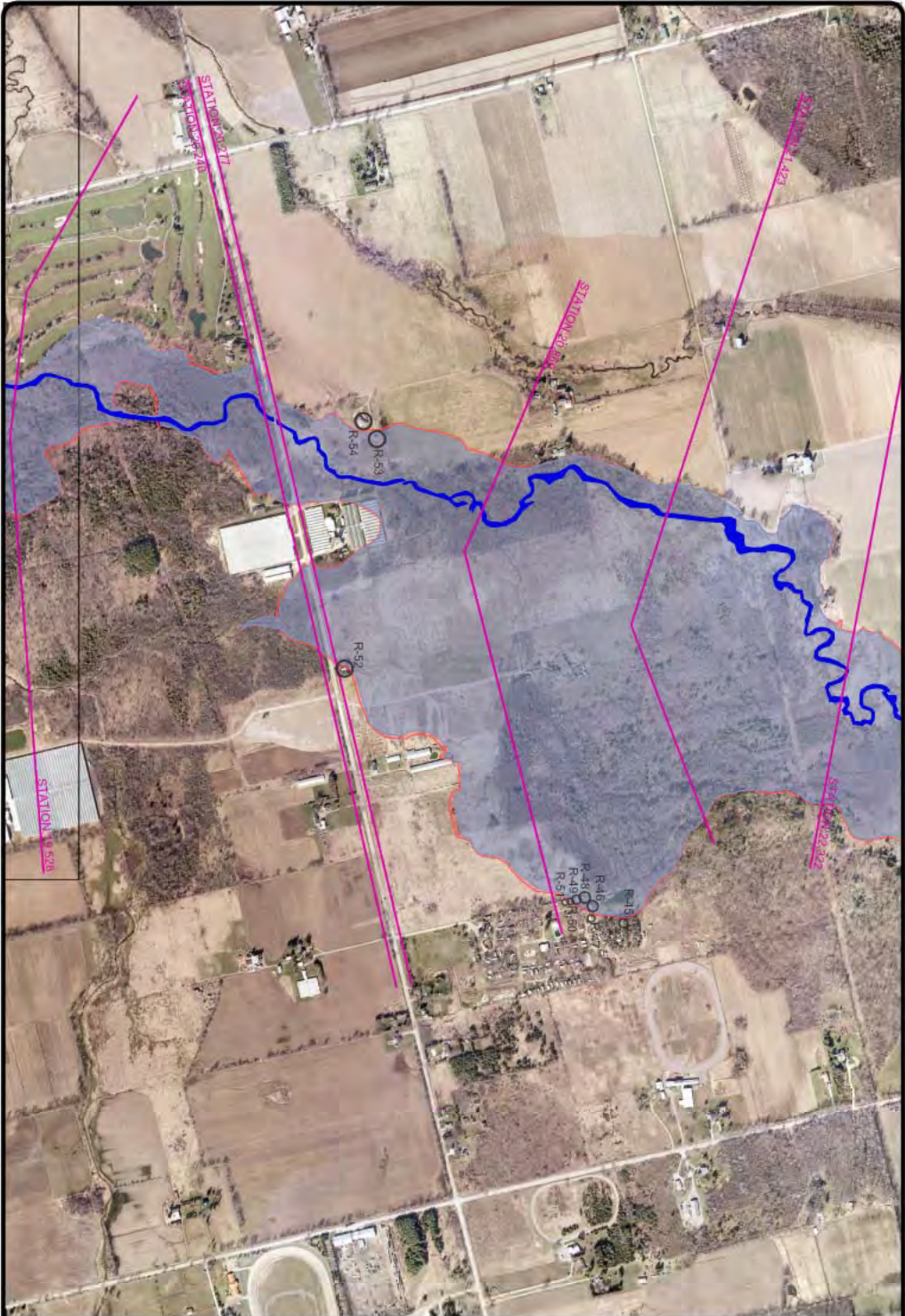
BUILDING	TOWNSHIP	SEPARATOR	BREAK
ELEVATION (m)	ELEVATION (m)	ELEVATION (m)	WATER
R-38	262.44	240.38	246.93
R-39	262.44	240.38	246.93
R-40	261.00	248.33	248.22
R-41	261.00	248.33	248.22
R-42	261.00	248.33	248.22
R-43	261.00	248.33	248.22
R-44	261.00	248.33	248.22





Hamilton Conservation Authority

- LEGEND**
- LOCATION OF CROSS SECTION
 - NORMAL SUMMER WATER LEVEL
 - INUNDATION DUE TO DAM FAILURE
 - 17' INUNDATION
 - 400' BUILDING WITH INUNDATION AREA



BUILDING	FOREST	OFF-WATER	BREAST
ELEVATION (m)	ELEVATION (m)	ELEVATION (m)	ELEVATION (m)
R-48	26.77	26.77	26.77
R-47	26.58	26.58	26.58
R-46	26.53	26.53	26.53
R-45	26.59	26.59	26.52
R-44	26.54	26.54	26.52
R-43	26.54	26.54	26.52
R-42	26.54	26.54	26.52
R-41	26.54	26.54	26.52
R-40	26.54	26.54	26.52
R-39	26.54	26.54	26.52
R-38	26.54	26.54	26.52
R-37	26.54	26.54	26.52
R-36	26.54	26.54	26.52
R-35	26.54	26.54	26.52
R-34	26.54	26.54	26.52



Project: **VALENS DAM**
DAM BREAK ANALYSIS

Title: **INFLOW DESIGN FLOOD CONDITION**

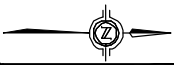
Approved by: **S.K.** Date: **JAN. 13/2012** Project No.: **BRM00601226a**

Drawn by: **M.B.S.** Scale: **1:10000** Figure no.: **F-07**

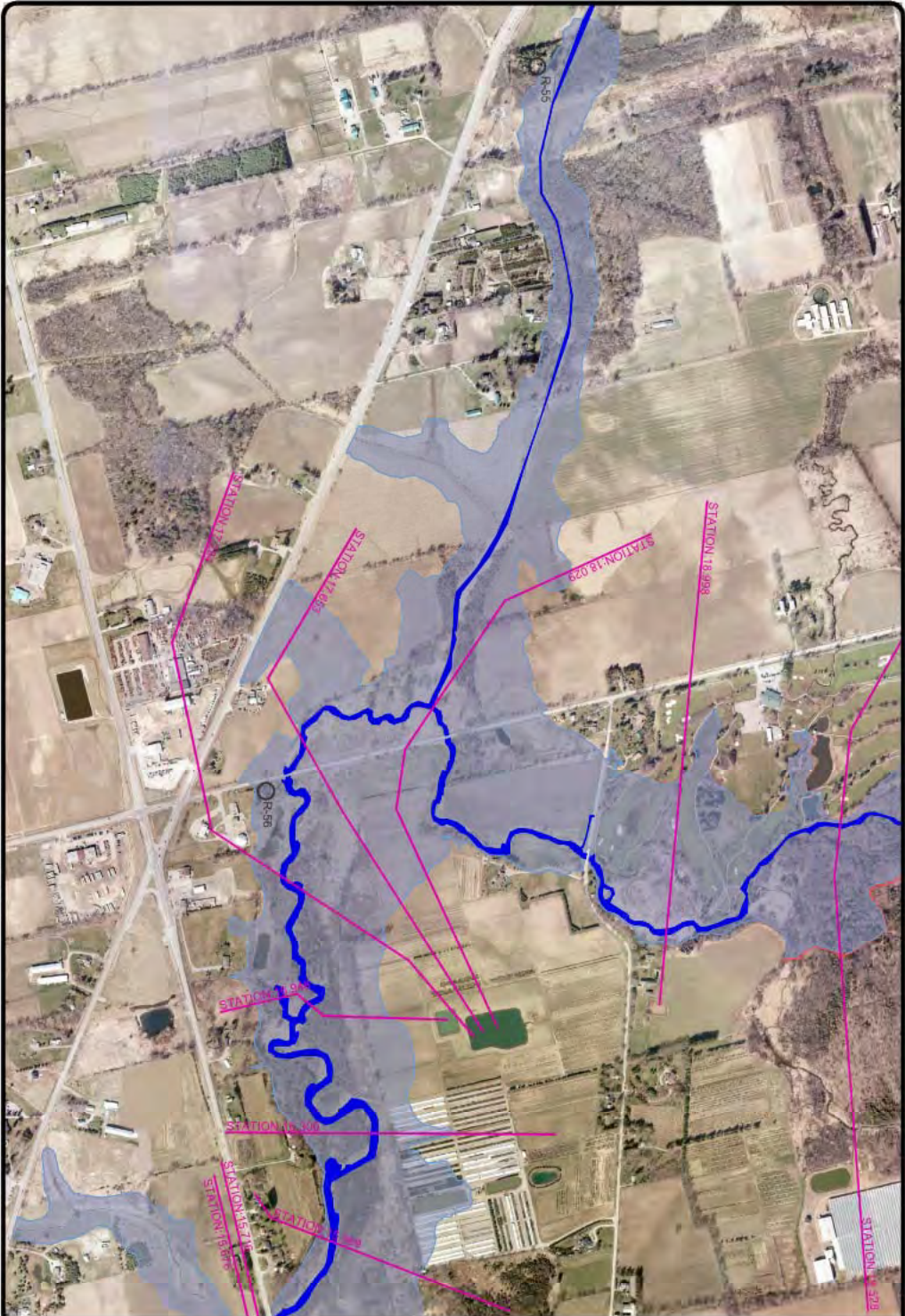


**Hamilton
Conservation Authority**

- LEGEND**
- LOCATION OF FLOOD SECTION
 - NORMAL SUMMER WATER LEVEL
 - INUNDATION DUE TO DAM FAILURE
 - 17th FLOODWAY
 - BUILDING WITH INUNDATION
 - 400' AREA



Project:		VALENS DAM	
Title:		DAM BREAK ANALYSIS	
INFLOW DESIGN FLOOD CONDITION			
Approved by:	S.K.	Date:	JAN. 13/2012
Drawn by:	M.B.S.	Scale:	1:10000
Project No.:		BRM006012266a	
Figure No.:		F-08	



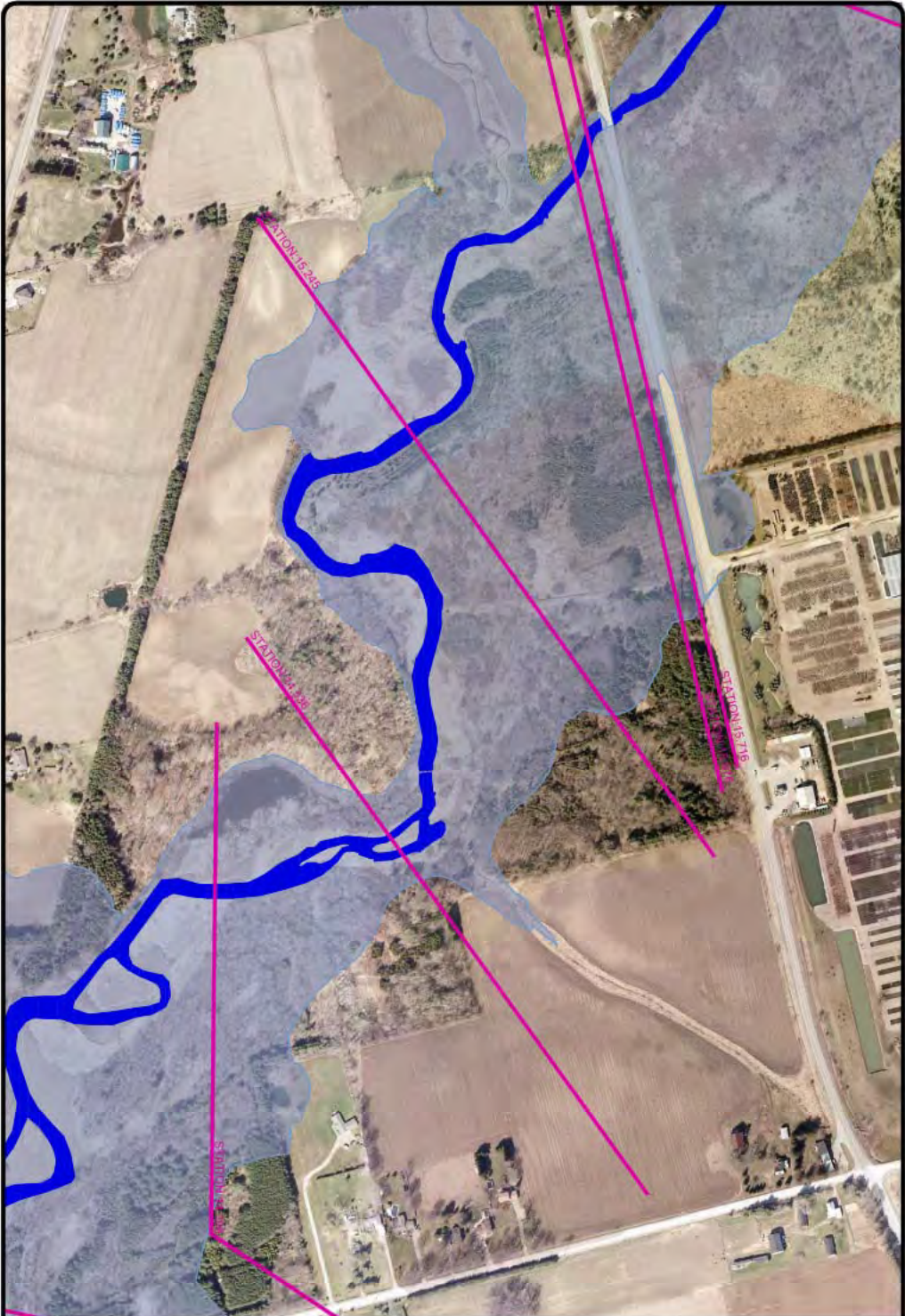
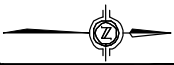
BUILDING	TOWNSHIP	OFF-WATER	BRIDGE
ELEVATION (m)	ELEVATION (m)	ELEVATION (m)	ELEVATION (m)
R-55	2888	2853	2853
R-56	2752	2821	2821





Hamilton
Conservation Authority

- LEGEND**
- LOCATION OF CROSS SECTION
 - NORMAL SUMMER WATER LEVEL
 - INUNDATION DUE TO DAM FAILURE
 - 1% INUNDATION
 - BUILDING WITHIN INUNDATION AREA

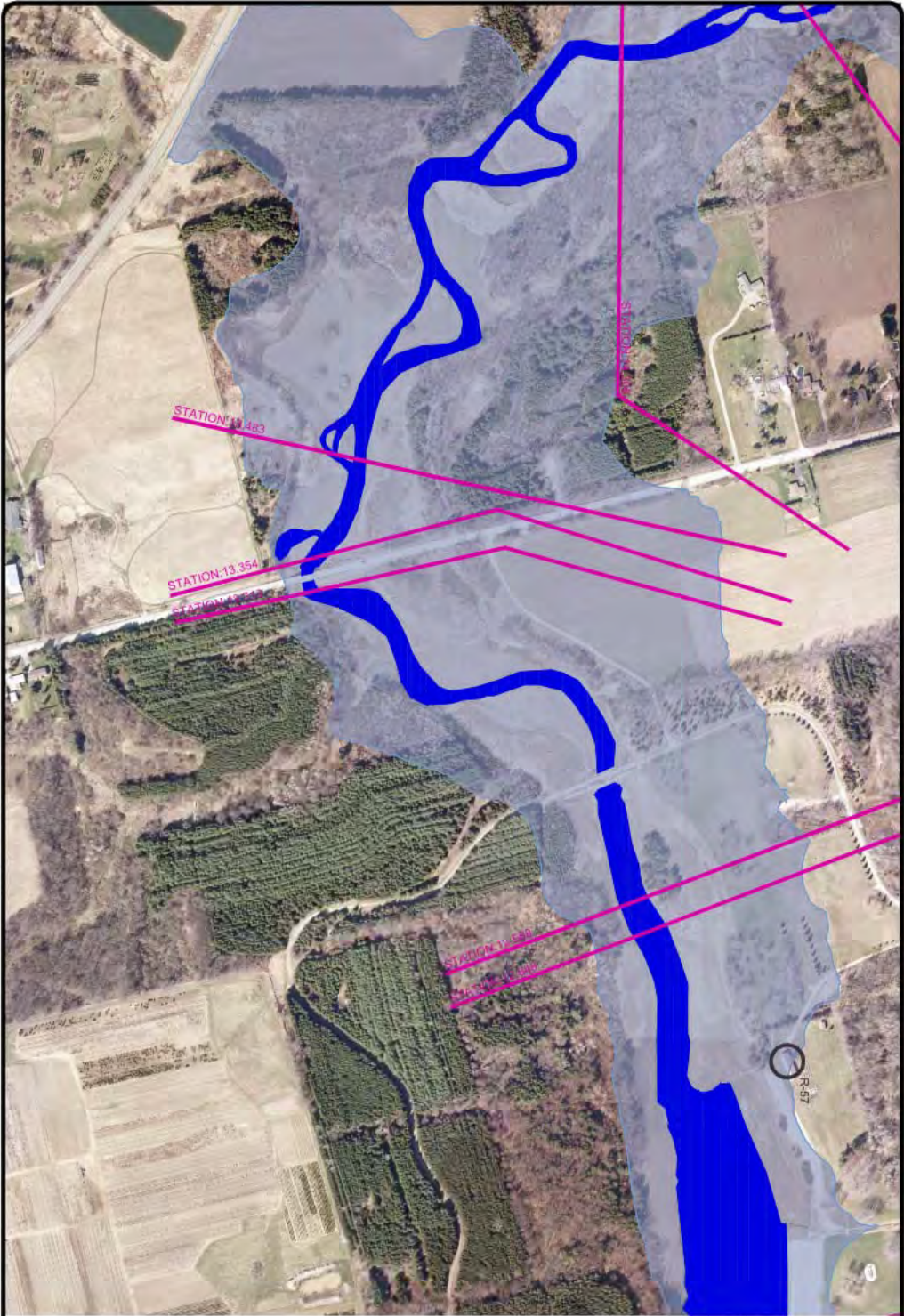


Project:		VALENS DAM	
Title:		DAM BREAK ANALYSIS	
INFLOW DESIGN FLOOD CONDITION			
Approved by:	S.K.	Date:	JAN. 13/2012
Drawn by:	M.B.S.	Scale:	1:5000
Project No.:		BRM00601226a	
Figure No.:		F-09	



Hamilton
Conservation Authority

- LEGEND**
- LOCATION OF FLOOD SECTION
 - █ NORMAL SUMMER WATER LEVEL
 - █ INUNDATION DUE TO DAM FAILURE
 - █ 17% INUNDATION
 - █ BUILDING WITH INUNDATION AREA



	LOWEST ELEVATION (m)	SEPARATOR ELEVATION (m)	BREACH WATER ELEVATION (m)
R-57	286.29	287.12	287.12



Project:		VALENS DAM	
Title:		DAM BREAK ANALYSIS	
Approved by:		S.K.	
Date:		JAN. 13/2012	
Project No.:		BRM006012266a	
Drawn by:		M.B.S.	
Scale:		1:5000	
Figure no.:		F-10	

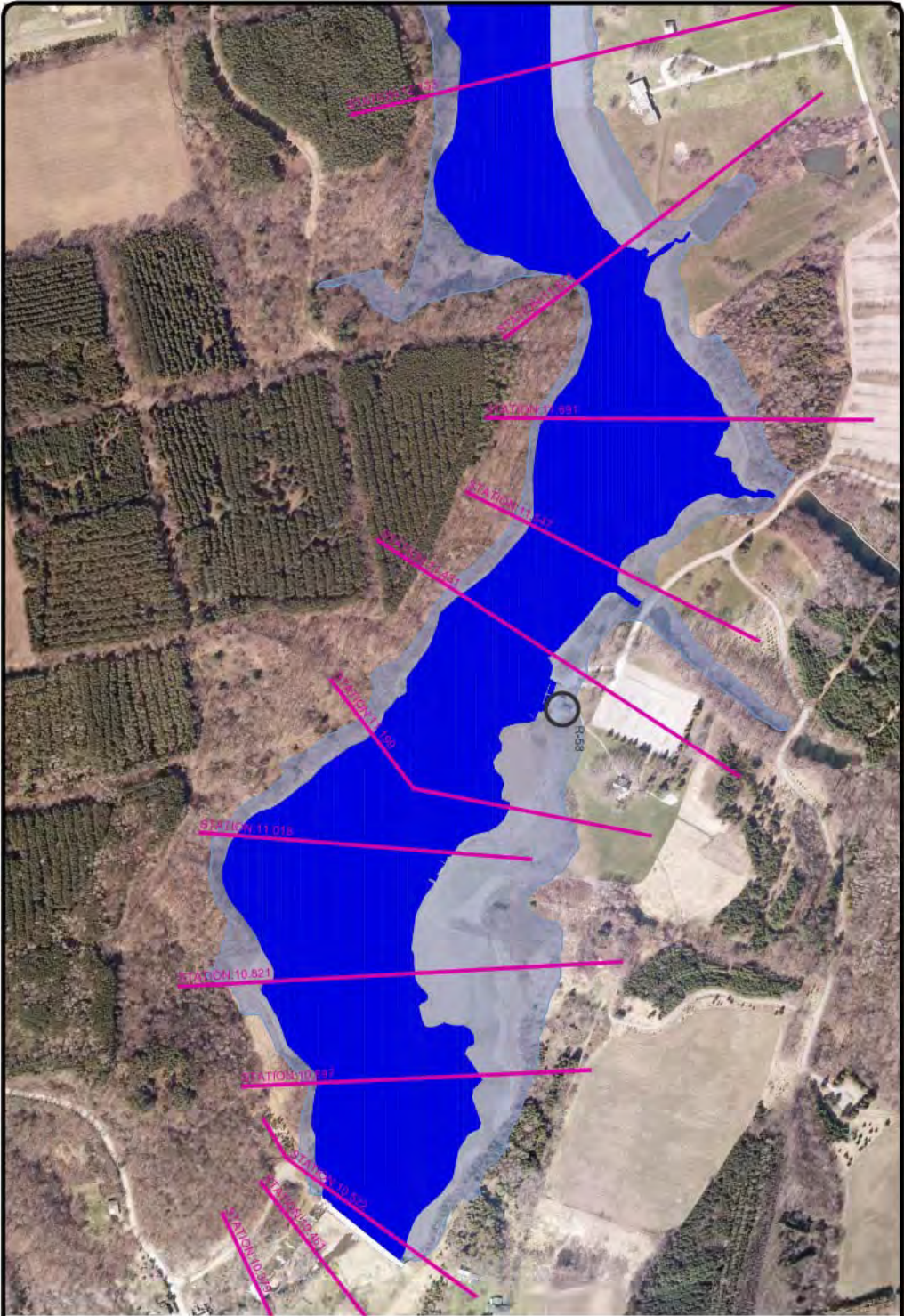


Hamilton
Conservation Authority

- LEGEND**
- LOCATION OF CROSS SECTION
 - NORMAL SUMMER WATER LEVEL
 - INUNDATION DUE TO DAM FAILURE
 - 175' INUNDATION
 - BUILDING WITHIN INUNDATION AREA



Project:		VALENS DAM	
Title:		DAM BREAK ANALYSIS	
INFLOW DESIGN FLOOD CONDITION			
Approved by:	S.K.	Date:	JAN. 13/2012
Drawn by:	M.B.S.	Scale:	1:5000
Project No.:		BRM00601226a	
Figure No.:		F-11	



SECTION	BUILDING ELEVATION (m)	LOWEST ELEVATION (m)	CROSSING ELEVATION (m)	BREACH WATER ELEVATION (m)
R-108	257.77	257.77	257.77	257.77



This page intentionally left blank.

APPENDIX C - REFERENCE PHOTOGRAPHS

Photo 1: Looking upstream from dam crest (July 2011)



Photo 2: View of upstream face of dam (April 2011)

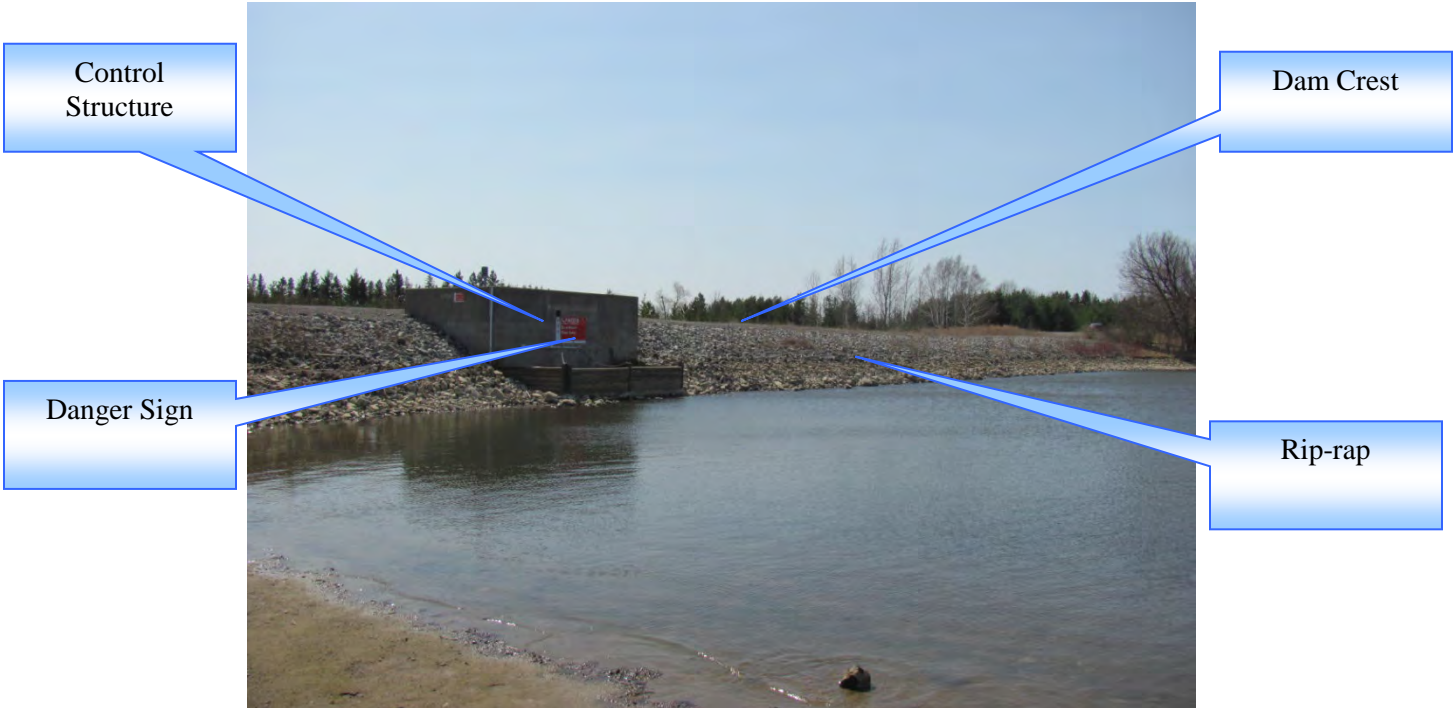


Photo 3: View of upstream face of control structure (April 2011)

Staff Gauge



Photo 4: Looking downstream from outlet structure (July 2011)

Danger Sign

Spencer Creek

Handrail



Photo 5: Downstream view of outlet structure (July 2011)

Handrail



Low Flow Outlet

Photo 6: Looking south at dam (July 2011)



Dam
Crest/Roadway

Photo 7: Looking north at dam (July 2011)



Dam
Crest/Roadway

Photo 8: Drop inlet structure (July 2011)



Stoplogs

Steel Grates

Photo 9: Downstream toe (July 2011)



Outlet Structure

Photo 10: Automatic water level gauge with data logger (July 2011)



APPENDIX C

Public Safety Plans

APPENDIX C.1

Christie Lake Dams

Public Safety Plans



Draft Public Safety Plan

Christie Lake Dam

Hamilton, Ontario

D.M. Wills Project Number 20-5426



D.M. Wills Associates Limited
Partners in Engineering, Planning and
Environmental Services
Peterborough



April 2022

Prepared for:
Hamilton Conservation Authority

Summary of Revisions

Rev. No.	Revision Title	Date	Summary of Revisions
1	Draft PSP	April 14, 2022	Issued for Client Review

This report/proposal has been formatted considering the requirements of the Accessibility for Ontarians with Disabilities Act.

Authorization

This document has been developed to document the public safety measures at the Christie Lake Dam in Hamilton, Ontario

Prepared by:

David Green, P.Eng.
Assistant Manager, Water Resources Engineering
D.M. Wills Associates Limited

Date:

Approved by:

Scott Peck, MCIP, RPP
Deputy Chief Administrative Officer /
Director, Watershed Management Services
Hamilton Conservation Authority

Date:

Table of Contents

1.0	Introduction	5
2.0	Purpose	5
2.1	Topics Covered by the Public Safety Plan	5
2.2	Topics NOT Covered by the Public Safety Plan.....	6
3.0	Roles and Responsibilities.....	6
3.1	Hamilton Conservation Authority	6
3.2	Management Staff	6
4.0	Site Description.....	7
4.1	Site Location	7
4.2	General Site Layout	7
4.3	Operational Procedures	11
5.0	Risk Assessment Summary.....	14
5.1	Component Areas.....	14
5.2	Public Activities and Potential Hazards	16
5.3	Risk Levels.....	20
6.0	Existing Control Measures and Opportunities for Improvement.....	20
6.1	Overview of Public Safety Control Measures Purpose	20
6.2	Existing Control Measures	20
6.2.1	Upstream Area	20
6.2.2	Headpond.....	22
6.2.3	Structure.....	23
6.2.4	Main Spillway.....	26
6.2.5	Low Flow / Emergency Spillway	28
6.2.6	Downstream Area	28
6.2.7	Darnley Mills Ruins.....	29
6.3	Opportunities for Improvement	32
7.0	Inspection and Maintenance Program	35
8.0	Public Education Plan	37
9.0	Incident Reporting.....	38
10.0	Record Management	38

Figures

Figure 1 – Location Plan.....	12
Figure 2 – General Site Plan.....	13
Figure 3 – Component Areas.....	15
Figure 4 – Existing Public Safety Measures.....	31

Tables

Table 1 – Public Activities and Potential Hazards.....	16
Table 2 – Inspection and Maintenance Requirements.....	35

Appendices

Appendix A - Forms and Reports
Appendix B - Sign Index
Appendix C - Sample Public Notifications

1.0 Introduction

D.M. Wills Associates Limited (Wills) was retained by the Hamilton Conservation Authority (HCA) to complete a Public Safety Plan (PSP) for the Christie Lake Dam. This PSP has been prepared in accordance with the Canadian Dam Association (CDA) Guidelines for Public Safety Around Dams (CDA, 2011) and considers the Best Management Practices for Public Safety Around Dams (MNR, 2011).

The PSP utilizes information obtained through a site visit that was completed by Wills and the HCA on November 17, 2020. The public safety hazards, risk levels and risk reduction recommendations contained in this PSP are a summary, based on information documented within the Final Public Safety Risk Assessment Report dated March 2021.

Electronic copies of this PSP are held in the HCA's and Wills' files. Hardcopies have not been distributed.

2.0 Purpose

This document has been developed for two (2) purposes:

1. Summarize the hazards associated with the dam and its operation, describe the risks associated with the hazards and recommend control measure that, when implemented, will eliminate or reduce the risk of public injury or death during normal operations.
2. Outline the roles, responsibilities, procedures and timelines that are required in order for the HCA to demonstrate public safety due diligence.

2.1 Topics Covered by the Public Safety Plan

The following topics are covered in this PSP:

- Roles and responsibilities of the HCA;
- A description of the facility to which this PSP applies;
- Risk Assessment summary, including:
 - Public activities in the areas affected by the facility;
 - Hazards to the public that may be present;
 - Safety control measures that are currently employed to protect the public during normal operations;
 - Safety control measures that, when implemented, will address public safety hazards and risks created by normal operation;
- Procedures for inspection, remediation and modification of safety controls;
- Relevant mapping of the component areas;

- Sign index, or future sign index;
- Sign inventory for inspection purposes;
- Public education;
- Records management; and
- Incident reporting.

2.2 Topics NOT Covered by the Public Safety Plan

The following topics are NOT covered in this PSP:

- Areas outside of the component area boundaries, including Christie Lake;
- Private property;
- Properties under the control of a third party (i.e. properties leased to a third party) that are unaffected by the dam or its operations; and
- Property owned by the Crown or others including public roads and provincial, municipal and conservation area lands and facilities that are unaffected by the dam or its operation.

This PSP is applicable throughout the range of normal operating conditions. Situations outside of the range of normal operations (e.g. spilling, summer drawdowns for maintenance) are the subject of separate protocols, which supersede this PSP.

The term “public” does NOT refer to HCA staff or contractors working for the HCA. Safety practices for these workers are to be managed in accordance with the requirements of the Occupational Health and Safety Act and its applicable Regulations and the HCA’s health and safety policies.

3.0 Roles and Responsibilities

3.1 Hamilton Conservation Authority

The HCA has an obligation to:

- Understand public use within areas affected by the operation of its facilities;
- Identify the hazards and risks involved with public use of areas affected by the HCA’s assets and their operations; and
- Take all reasonably appropriate steps to remove or, where that is not possible, to reduce the public safety risks.

3.2 Management Staff

HCA Management Staff are responsible for ensuring that a PSP is prepared, implemented and maintained. Specifically, Management Staff are responsible for ensuring that:

- A PSP is in place and aligns with the requirements of the HCA's public safety policies;
- Inspections and remedial measures are performed, as required, under the PSP;
- Records are kept of inspections and remedial measures;
- Training is conducted so that staff involved can fulfill their respective roles and responsibilities;
- Safety controls are implemented or modified when changes to the physical structure or operating procedures may create an additional or modified public safety risk;
- Monitoring compliance with the PSP; and
- Revisions to the PSP are performed as and when required, and that revised pages are sent for revisions of the digital copy and subsequent updates to PSP websites if applicable.

4.0 Site Description

4.1 Site Location

The Christie Lake Dam is located on Lot 6, Concession 2 in the Geographic Township of West Flamborough, City of Hamilton, Ontario. The dam controls the discharge from Christie Lake into Spencer Creek, which ultimately discharges into Lake Ontario. The primary access to the dam is via a gated access road from Crooks Hollow Road and Hamilton Regional Road 8. The location of the dam site is shown in Figure 1.

The dam and lake are part of the Christie Lake Conservation Area, which is owned by the HCA. The Christie Lake Conservation Area provides a number of recreational facilities, including trails, picnic areas, a marina, soccer fields, a disc golf course, a baseball diamond, beach volleyball courts and a swimming beach. The trail system provides access to the majority of areas on the property, including the pedestrian walkway that crosses the dam.

4.2 General Site Layout

The Christie Lake Dam was constructed in 1972 and underwent major maintenance, including structural repairs/improvements and public safety upgrades, in 2005. The dam provides water level and discharge control for the purposes of low flow augmentation, flood control, recreation and habitat creation. The dam is located within the Christie Lake Conservation Area. The general site plan for the dam site is provided in Figure 3.

The Christie Lake Dam site is comprised of the following key elements:

- An access driveway and gate (Photo 1), an access road (Photo 2) and a parking area (Photo 3). The access gate is locked, blocking public vehicular access to the parking area.

- A control building (Photo 4) that houses, among other things, the power and control mechanisms for the main spillway gates. The doors to the control building are locked and there is an alarm system for the building.
- A main spillway consisting of two (2) ogee spillways with crest elevations of 231.65 m. The ogee spillways are controlled by 4.88 m wide by 4.88 m high radial gates during summer operations and 1.52 m high steel panels during winter operations (Photo 5). There is a spillway structure, with stilling basin, downstream of the ogee spillways and gates (Photo 6).
- An approximately 109 m long overflow weir with a crest elevation of 235.93 m. Flashboards, measuring 0.6 m high, are installed on top of the overflow weir and can be removed in the event of a major flood. The ogee weir is shown in Photo 7 and the flashboards can be seen in Photo 9.
- A pedestrian walkway across the top of the dam (Photo 8).
- A drop inlet structure containing three (3) 1.83 m wide stoplog controlled bays, two (2) 0.6 m x 0.6 m gate valves and a 0.15 m diameter low flow valve. The stoplog bays have a sill elevation of 234.48 m. 0.53 m high (total) stop logs are installed in each bay during summer. The gate valves have an invert elevation of 229.52 m. The low flow valve has an invert elevation of 231.50 m.

The drop inlet structure deck is shown in Photo 9, the upstream side of the drop inlet structure is shown in Photo 10 and the low flow outlet is shown in Photo 11. Flows out of the low flow outlet are discharged through the low flow channel (Photo 12) that flows through the emergency spillway (Photo 13).

Along the low flow channel there is the remnants of an old bridge structure (Photo 14) and the Darnley Cascade (Photo 15), a natural feature.

- A former mill (Darnley Mill Ruins) (Photo 16) is located on the west side of the creek, immediately upstream of Crooks Hollow Road.
- A conservation area that includes a number of recreational facilities, including trails, picnic areas, a marina, soccer fields, a disc golf course, a baseball diamond, beach volleyball courts and a swimming beach.



Photo 1 – Access Driveway/Gate



Photo 2 – Access Road



Photo 3 – Parking Area



Photo 4 – Control Building



Photo 5 – Main Spillway Gates



Photo 6 – Main Spillway



Photo 7 – Overflow Weir



Photo 8 – Pedestrian Walkway



Photo 9 – Drop Inlet Structure Deck



Photo 10 – Drop Inlet Structure



Photo 11 – Low Flow Outlet



Photo 12 – Low Flow Channel



Photo 13 – Emergency Spillway



Photo 14 – Bridge Remnants



Photo 15 – Darnley Cascade



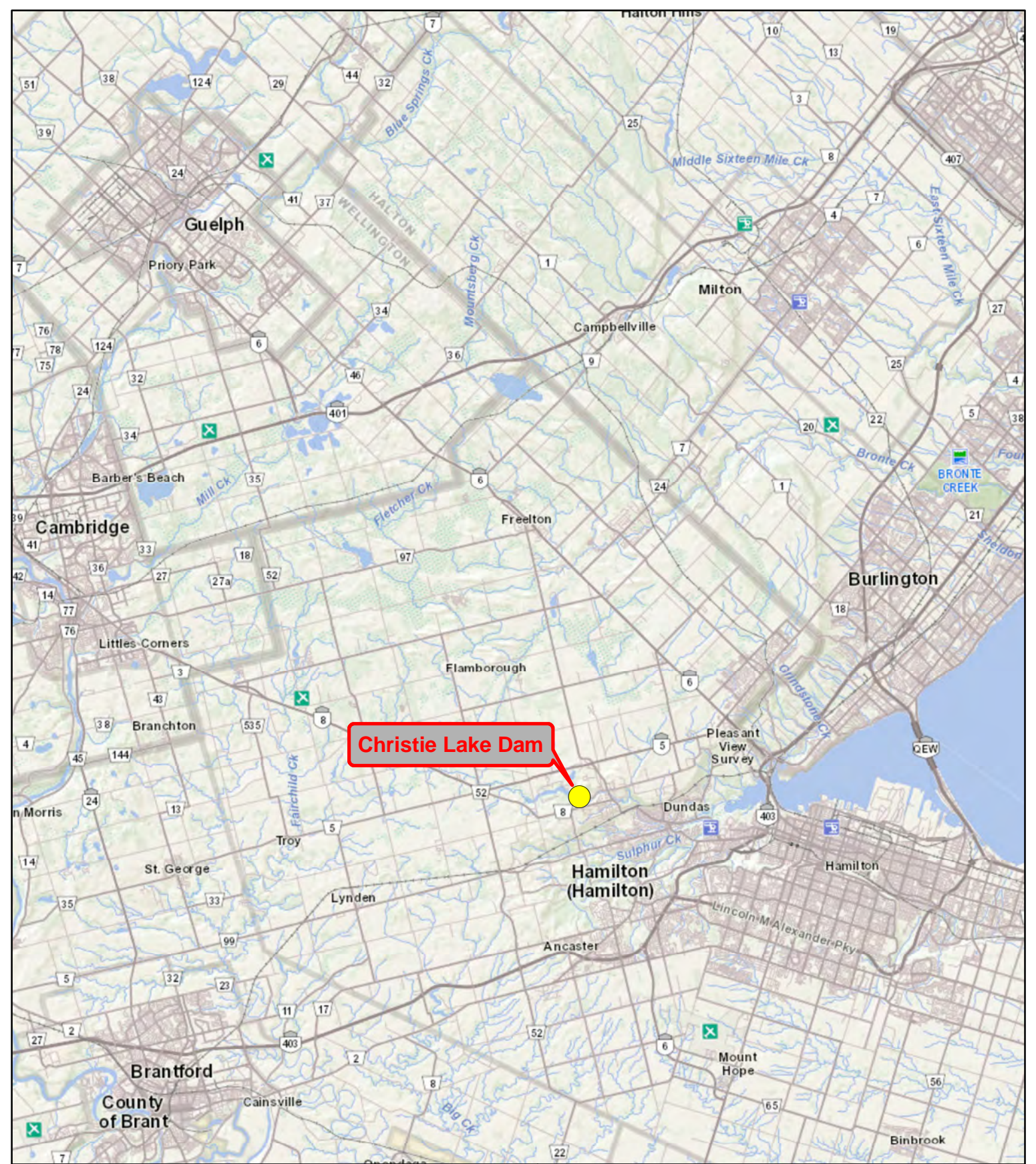
Photo 16 – Darnley Mill Ruins

4.3 Operational Procedures

The dam is operated by HCA operations staff. The types of operations conducted at the site include:

- Seasonal operations of the various flow control equipment/structures.
- Emergency operations of the various flow control equipment/structures.
- Removal of debris and ice.

Dam operations are conducted in accordance with the Draft Operation, Maintenance, Surveillance and Safety Manual (Hamilton Conservation Authority, undated).



Christie Lake Dam

Legend

 Christie Lake Dam

Data Sources
Land Information Ontario 2020
Created In: ArcMap 10.7

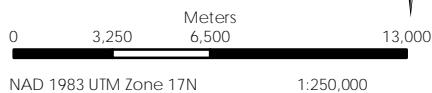


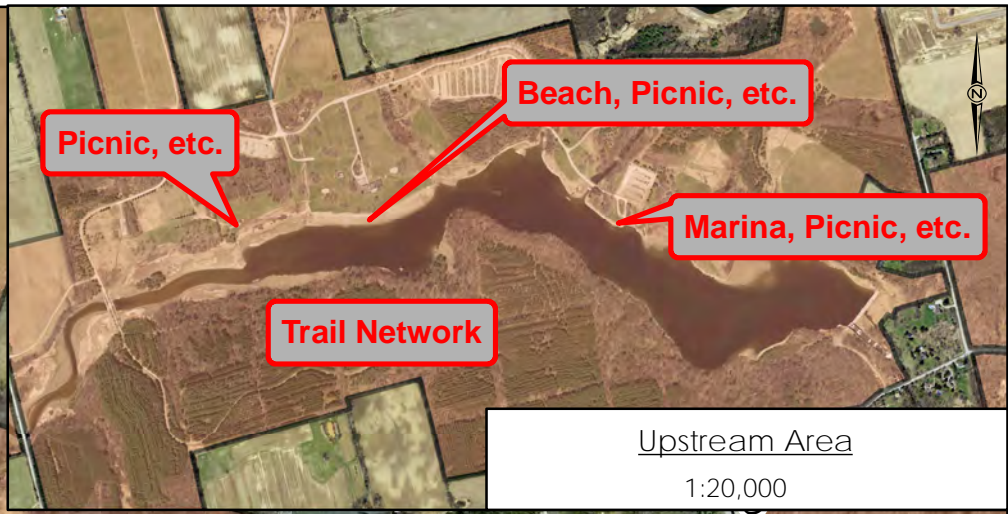
Figure 1 - Location Plan

Drawn By:	DG
Checked By:	DG
Map Date:	12/14/20
Project Number:	20-5426
File Number:	20201214-5426



D.M. Wills Associates Limited
150 Jameson Drive
Peterborough, Ontario
K9J 0B9

P. 705.742.2297
F. 705.748.9944
E. wills@dmwills.com
Copyright © D.M. Wills 2020



Upstream Area
1:20,000



Legend

- HCA Property Ownership
- Arterial
- Local

Data Sources
Land Information Ontario 2020
Created In: ArcMap 10.7

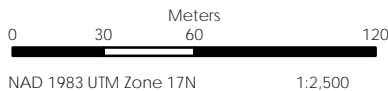


Figure 2 - General Site Plan

Drawn By:	DG
Checked By:	DG
Map Date:	12/14/20
Project Number:	20-5426
Map File Number:	201109-5426



D.M. Wills Associates Limited
150 Jameson Drive
Peterborough, Ontario
K9J 0B9

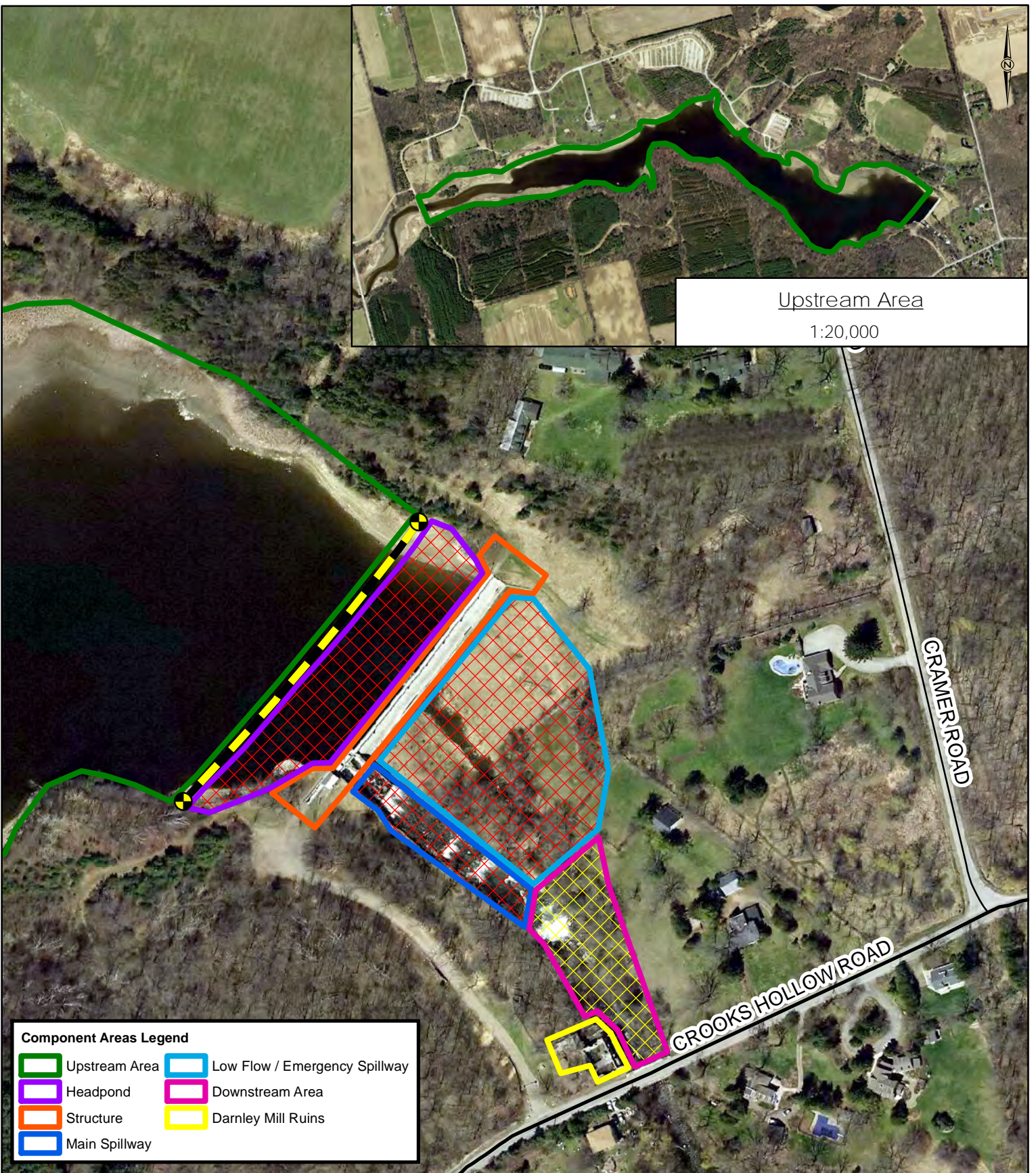
P. 705.742.2297
F. 705.748.9944
E. wills@dmwills.com
Copyright © D.M.Wills 2020

5.0 Risk Assessment Summary

5.1 Component Areas

As shown in Figure 3 and described in the Final Public Safety Risk Assessment Report (Wills, 2021), the dam site has been divided into seven (7) main components, namely:

1. **Upstream Area:** The Upstream Area component area boundary extends from the upstream side of the public safety boom to the downstream side of the Round the Lake Trail crossing of the Christie Reservoir (~2.1 km) and encompasses the reservoir shoreline to a distance of 2 m back from the water's edge.
2. **Headpond:** The Headpond component area boundary extends from the upstream side of the dam to the downstream side of the public safety boom and encompasses the reservoir shoreline to a distance of 2 m back from the water's edge.
3. **Structure:** The Structure component area boundary includes the entire dam structure and abutments.
4. **Main Spillway:** The Main Spillway component area boundary extends from the downstream side of the dam to a distance of approximately 100 m downstream where the flow from the main spillway joins the creek channel. The width of the component area is approximately 20 m. In the area with the high concrete walls, the component area extends to the outside of the concrete walls. In the area with the tiered retaining walls, the component boundary extends to a distance of 2 m back from the top of the wall.
5. **Low Flow/Emergency Spillway:** The Low Flow/Emergency Spillway component area boundary extends from the downstream side of the dam to a distance of approximately 100 m downstream where the flow from the main spillway joins the creek channel. The component area is bounded by the Main Spillway component area on the right and the top of slope on the left. The width ranges from approximately 100 m to approximately 40 m, narrowing towards the downstream end.
6. **Downstream Area:** The Downstream Area component area boundary extends from the downstream side of the Main Spillway and Low Flow/Emergency Spillway component area boundaries to the upstream side of Crooks Hollow Road (~100 m) with an average width of approximately 30 m centered on the center of the watercourse. The Darnley Mill ruins are excluded as described in the Darnley Mill Ruins component area boundary description.
7. **Darnley Mill Ruins:** The Darnley Mill Ruins component area boundary is comprised of the fencing around the ruins and the exterior walls of the former mill building.



Component Areas Legend

	Upstream Area		Low Flow / Emergency Spillway
	Headpond		Downstream Area
	Structure		Darnley Mill Ruins
	Main Spillway		

Legend

- Public Safety Boom Anchors
- Public Safety Boom Line

Dangerous Waters Identification

- Danger Area
- Warning Area

Data Sources
 Land Information Ontario 2020
 Created In: ArcMap 10.7

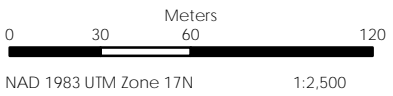


Figure 3 - Component Areas

Drawn By:	DG
Checked By:	DG
Map Date:	12/14/20
Project Number:	20-5426
Map File Number:	201109-5426



D.M. Wills Associates Limited
 150 Jameson Drive
 Peterborough, Ontario
 K9J 0B9
 P. 705.742.2297
 F. 705.748.9944
 E. wills@dmwills.com
 Copyright © D.M.Wills 2020

5.2 Public Activities and Potential Hazards

Table 1 lists the known and expected public activities and the potential hazards at the Christie Lake Dam.

Table 1 – Public Activities and Potential Hazards

Activity Descriptions	Potential Hazards
Upstream Area	
From Water / Ice	
<ul style="list-style-type: none"> • Fishing from Boat • Boating (Under Power) • Canoeing / Kayaking / Rowing • Paddle Boarding 	<ul style="list-style-type: none"> • Floating Debris • Wind / Rough Water
<ul style="list-style-type: none"> • Paddle Boarding 	<ul style="list-style-type: none"> • Steep or Slippery Banks • Thin Ice
From Shore / Structure	
<ul style="list-style-type: none"> • Fishing from Shore • Walking • Climbing • Camping • Picnicking • Hiking • Biking • Swimming / Diving 	<ul style="list-style-type: none"> • Steep or Slippery Banks
<ul style="list-style-type: none"> • Skiing • Snowshoeing 	<ul style="list-style-type: none"> • Steep or Slippery Banks • Thin Ice
Headpond	
From Water / Ice	
<ul style="list-style-type: none"> • Fishing from Boat • Canoeing / Kayaking / Rowing • Swimming / Diving 	<ul style="list-style-type: none"> • Strong Currents or Undertows • Presence of Spillway with Sluiceway • Presence of Spillway with Stoplogs • Presence of Overflow Spillway or Dam • Presence of Discharge Valve / Pipe • Steep or Slippery Banks • Wind / Rough Water
<ul style="list-style-type: none"> • Ice Fishing 	<ul style="list-style-type: none"> • Strong Currents or Undertows

Activity Descriptions	Potential Hazards
	<ul style="list-style-type: none"> • Presence of Spillway with Sluicagate • Presence of Spillway with Stoplogs • Presence of Overflow Spillway or Dam • Presence of Discharge Valve / Pipe • Steep or Slippery Banks • Thin Ice
From Shore / Structure	
<ul style="list-style-type: none"> • Fishing from Shore • Walking • Hiking 	<ul style="list-style-type: none"> • Steep or Slippery Banks
<ul style="list-style-type: none"> • Skiing 	<ul style="list-style-type: none"> • Steep or Slippery Banks • Thin Ice
<ul style="list-style-type: none"> • Swimming / Diving 	<ul style="list-style-type: none"> • Strong Currents or Undertows • Presence of Spillway with Sluicagate • Presence of Spillway with Stoplogs • Presence of Overflow Spillway or Dam • Presence of Discharge Valve / Pipe • Steep or Slippery Banks • Wind / Rough Water
Structure	
From Shore / Structure	
<ul style="list-style-type: none"> • Fishing from Shore • Walking • Climbing • Hiking • Skiing • Snowshoeing • Biking 	<ul style="list-style-type: none"> • Falling from Height > 3 m • Open Holes or Tripping
<ul style="list-style-type: none"> • Swimming / Diving 	<ul style="list-style-type: none"> • Rapidly Increasing Water Levels • Rapidly Increasing Water Flows • Strong Currents or Undertows • Presence of Spillway with Sluicagate • Presence of Spillway with Stoplogs • Presence of Overflow Spillway or Dam • Presence of Discharge Valve/Pipe

Activity Descriptions	Potential Hazards
	<ul style="list-style-type: none"> • Falling from Height > 3 m • Unsecured Mechanical/Electrical Equipment • Unsecured or Exposed Live Electrical Conductors • Open Holes or Tripping
Main Spillway	
From Water/Ice	
<ul style="list-style-type: none"> • Canoeing / Kayaking / Rowing 	<ul style="list-style-type: none"> • Rapidly Increasing Water Levels • Rapidly Increasing Water Flows • Strong Currents or Undertows • Presence of Spillway with Sluiceway • Submerged Hydraulic Jump • Steep or Slippery Banks • Falling from Height > 3 m
From Shore / Structure	
<ul style="list-style-type: none"> • Fishing from Shore • Walking • Hiking • Driving • Biking 	<ul style="list-style-type: none"> • Steep or Slippery Banks • Falling from Height > 3 m • Changing Flow/Depth May Result in Stranding • Unsecured or Exposed Live Electrical Conductors • Inadequate Guardrails/Handrails for Public • Open Holes or Tripping
Low Flow / Emergency Spillway	
From Shore / Structure	
<ul style="list-style-type: none"> • Fishing from Shore • Walking • Climbing 	<ul style="list-style-type: none"> • Rapidly Increasing Water Levels • Rapidly Increasing Water Flows • Strong Currents or Undertows • Presence of Spillway with Sluiceway • Presence of Spillway with Stoplogs • Presence of Overflow Spillway or Dam • Presence of Discharge Valve/Pipe • Steep or Slippery Banks

Activity Descriptions	Potential Hazards
	<ul style="list-style-type: none"> • Changing Flow/Depth May Result in Stranding • Open Holes or Tripping • Masonry/Concrete in Poor Condition
<ul style="list-style-type: none"> • ATV / Dirt Biking • Hiking • Skiing • Snowshoeing • Biking • Tobogganing 	<ul style="list-style-type: none"> • Rapidly Increasing Water Levels • Rapidly Increasing Water Flows • Strong Currents or Undertows • Presence of Spillway with Sluiceway • Presence of Spillway with Stoplogs • Presence of Overflow Spillway or Dam • Presence of Discharge Valve/Pipe • Steep or Slippery Banks • Changing Flow/Depth May Result in Stranding • Open Holes or Tripping
Downstream Area	
From Water / Ice	
<ul style="list-style-type: none"> • Canoeing / Kayaking / Rowing • Playing in Darnley Cascade 	<ul style="list-style-type: none"> • Rapidly Increasing Water Levels • Rapidly Increasing Water Flows • Strong Currents or Undertows • Steep or Slippery Banks • Falling from Height > 3 m • Changing Flow/Depth May Result in Stranding • Open Holes or Tripping
From Shore / Structure	
<ul style="list-style-type: none"> • Fishing from Shore • Walking • Climbing • Picnicking 	<ul style="list-style-type: none"> • Steep or Slippery Banks • Falling from Height > 3 m
Darnley Mills Ruins	
From Shore / Structure	
<ul style="list-style-type: none"> • Walking • Climbing 	<ul style="list-style-type: none"> • Steep or Slippery Banks • Falling from Height > 3 m

Activity Descriptions	Potential Hazards
	<ul style="list-style-type: none"> • Inadequate Guardrails/Handrails for Public • Open Holes or Tripping • Masonry/Concrete in Poor Condition

5.3 Risk Levels

The Public Safety Risk Assessment for the Christie Lake Dam identified that fifty-nine (59) risks exist. These consist of seventeen (17) High risks, thirty-six (36) Medium risks and six (6) Low risks. However, these can be changed to zero (0) High risks, forty-five (45) Medium risks and fourteen (14) Low risks if the reduction measures that have been recommended in the Final Public Safety Risk Assessment Report (Wills, 2021) are implemented.

6.0 Existing Control Measures and Opportunities for Improvement

6.1 Overview of Public Safety Control Measures Purpose

Safety control measures at dams are initiatives designed to protect the public by the installation of physical restraints and by raising awareness of hazards and risks associated with the facility.

Where the risks are high, the consequences severe, a site may be designated a Danger Zone in which unauthorized access is prohibited, and appropriate control measures are implemented. Danger zone risks are generally restricted through the use of restraints and DANGER signs. A restraint is typically defined as a fence, gate, or boom.

Where the risks to life and limb are intermittent or less extreme, a site may be deemed a Warning Zone in which the public are alerted to the specific nature of the risk and warned accordingly. Warning zone risks are generally posted through on-site signage and public education. Public education is typically through media advertising, pamphlets, the corporate website and employee awareness.

Selection of the appropriate control measure depends upon the nature and degree of risk each safety hazard represents to the public. The practicality and effectiveness of implementation and the site-specific conditions being addressed will influence the choice of control measure used.

6.2 Existing Control Measures

6.2.1 Upstream Area

There are a number of public safety measures in place that have the potential to mitigate public safety hazards within the Upstream Area component area, including:

- Public Safety Signs – There are upstream facing public safety signs installed on the dam. The signs are located above the drop inlet structure and the main spillway. As shown in Photo 17, these signs are difficult to see from the majority of the component area; however, they would be visible once approaching the dam. There are also ice safety signs (Photo 18) installed at various locations within the component area during the winter months.
- Public Safety Boom and Buoys – There is a public safety boom as well as a safety buoy installed upstream of the dam. The public safety boom and safety buoy are intended to warn members of the public as they approach the dam and the public safety boom is intended to prevent entry into the Headpond component area (Danger Area). The public safety boom and safety buoy are difficult to see from the majority of the component area (Photo 17); however, they would be visible once approaching the dam. The safety buoy includes the words “UNSAFE ICE” and generally appears to be in good condition, with the exception of a buildup of bird droppings. The public safety boom has alternating red and white floats and is in very poor condition. The floatation units are cracked/broken and HCA staff reported that some floatation units do not maintain buoyancy. The public safety boom is removed for winter.
- Designated Swimming Area – There is a designated swimming area located within the Conservation Area (Photos 19 and 20). This encourages swimming in a relatively safe area and away from the dam.

The location of the existing public safety measures are shown in Figure 4 and the sign index is included in Appendix B.



Photo 17 – Public Safety Signs and Safety Boom/Buoy from Upstream Area



Photo 18 – Ice Safety Sign (Typical)



Photo 19 – Aerial View of Designated Swimming Area



Photo 20 – Ground Level View of Designated Swimming Area

6.2.2 Headpond

There are a number of public safety measures in place that have the potential to mitigate public safety hazards within the Headpond component area, including:

- Public Safety Signs – There are upstream facing public safety signs installed on the dam. The signs are located above the drop inlet structure (Photo 21) and the main spillway (Photo 22). The signs can be clearly seen from upstream of the public safety boom. There are also ice safety signs (Photo 18) installed at various locations within the component area during the winter months.
- Public Safety Boom and Buoys – There is a public safety boom as well as a safety buoy installed upstream of the dam. The public safety boom and safety buoy are intended to warn members of the public as they approach the dam and the public safety boom is intended to prevent entry into the Headpond component area (Danger Area). The public safety boom (Photo 23) and the safety buoy (Photo 24) would be visible as members of the public approach the dam. The safety buoy includes the words “UNSAFE ICE” and generally appears to be in good condition, with the exception of a buildup of bird droppings. The public safety boom has alternating red and white floats and is in very poor condition. The floatation units are cracked/broken and HCA staff reported that some floatation units do not maintain buoyancy. The public safety boom is removed for winter.
- Operational Controls (Procedures) – In Section 10 (Public Safety), the OMSS Manual states that the HCA Manager of Water Resources Engineering shall ensure that appropriate safety procedures are implemented to warn the public of potential hazards and/or restrict public access and that the dam operator must ensure access for unauthorized personnel during operations is prohibited; however, consideration for public safety is not included within Section 6 (Equipment, Tools and Safety Procedures). It is understood from staff on site that changes in flows are undertaken gradually, however, this is not expressly written in the OMSS Manual.

- Designated Swimming Area – There is a designated swimming area located within the Conservation Area (Photos 19 and 20). This encourages swimming in a relatively safe area and away from the dam (outside of the Headpond component area).

The location of the existing public safety measures are shown in Figure 4 and the sign index is included in Appendix B.



Photo 21 – Public Safety Sign
Above Drop Inlet Structure



Photo 22 – Public Safety Sign
Above Main Spillway

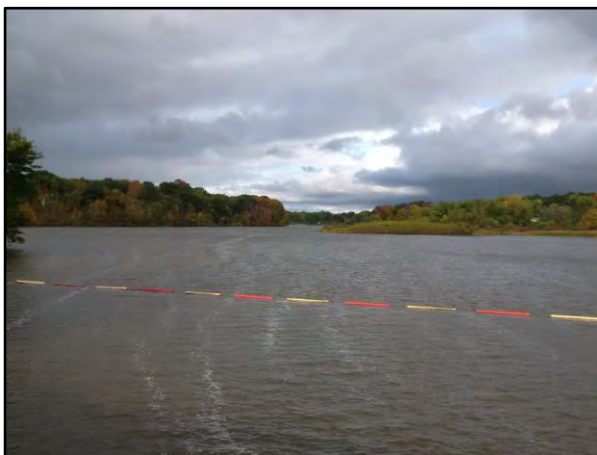


Photo 23 – Public Safety Boom



Photo 24 – Safety Buoy

6.2.3 Structure

There are a number of public safety measures in place that have the potential to mitigate public safety hazards within the Structure component area, including:

- Public Safety Signs – There are public safety signs warning members of the public installed on both the right (Photo 25) and left (Photo 26) sides of the dam. In addition there is a sign prohibiting the use of the overflow weir for skateboarding, biking and rollerblading (Photo 29). The signs are generally in good condition; however, the sign on the right side of the dam has some graffiti.

- Fencing/Railings – There is chain link fencing around the storage area for the winter gate panels (seen in Photo 27) and railings on the wingwalls and around all sections of the dam deck (typical railing shown in Photo 28). The fencing and railings appear to be adequate for their intended purposes.
- Barricades – Barricades have been installed at both ends of the dam structure (Photo 30). These barricades can be closed to block members of the public from accessing the deck of the dam during operations and maintenance. The gates are locked in the open position when they are not being used. There is also a barricade on the left side of the dam that would block larger vehicles (i.e. ATVs) from gaining access to the deck of the dam (Photo 31). It is understood that a person on horseback attempted to cross the dam but got stuck at this gate.
- Security Patrols – Staff from the Christie Lake Conservation Area visit the site daily. It is understood that these visits are being undertaken at different times each day. This is a good practice to ensure that time-specific public activities are identified.
- Video Surveillance and Control Building Security System – A security camera was previously installed on the control building. The security camera is missing, however, its mounting plate (Photo 33) and identification sign (Photo 34) remain. HCA staff indicated that they are in the process of replacing the security camera. There is also a security system installed in the control building. The security system protects both the upper and lower floors of the control building and there is a key pad (Photo 32) on the upper floor to arm/disarm the alarm.
- Designated Swimming Area – There is a designated swimming area located within the Conservation Area (Photos 19 and 20). This encourages swimming in a relatively safe area and away from the dam (outside of the Structure component area).

The location of the existing public safety measures are shown in Figure 5 and the sign index is included in Appendix C.



Photo 25 – Public Safety Sign on Right End of Storage Area for Winter Gate Panels



Photo 26 – Public Safety Sign on Left End of Pedestrian Walkway



Photo 27 – Storage Area for Winter Gate Panels



Photo 28 – Typical Pedestrian Walkway



Photo 29 – Public Safety Sign on Right End of Overflow Weir



Photo 30 – Typical Pedestrian Barricade



Photo 31 – Barricade on Left Side



Photo 32 – Security System Keypad Inside Control Building



Photo 33 – Broken Security Camera



Photo 34 – Security Camera Sign

6.2.4 Main Spillway

There are a number of public safety measures in place that have the potential to mitigate public safety hazards within the Main Spillway component area, including:

- Public Safety Signs – There are downstream facing public safety signs installed on the dam. The signs are located above main spillway (Photo 35) and the low flow outlet (Photo 36). The signs can be clearly seen from the Main Spillway and Low Flow / Emergency Spillway component areas.
- Public Safety Boom and Buoys – There is a public safety boom as well as a safety buoy installed upstream of the dam. The public safety boom and safety buoy are intended to warn members of the public as they approach the dam and the public safety boom is intended to prevent entry into the Headpond component area (Danger Area) and shall not allow members of the public to enter the Main Spillway component area. The public safety boom (Photo 23) and the safety buoy (Photo 24) would be visible as members of the public approach the dam. **The safety buoy includes the words “UNSAFE ICE” and generally appears to be in good condition, with the exception of a buildup of bird droppings.** The public safety boom has alternating red and white floats and is in very poor condition. The floatation units are cracked/broken and HCA staff reported that some floatation units do not maintain buoyancy. The public safety boom is removed for winter.
- Fencing/Railings – There is a railing along the top of the right retaining wall (Photo 37). The railing appears to be adequate for its intended purpose. There are no railings or fencing along the tops of the retaining walls (Photo 38).
- Security Patrols – Staff from the Christie Lake Conservation Area visit the site daily. It is understood that these visits are being undertaken at different times each day. This is a good practice to ensure that time-specific public activities are identified.
- Operational Controls (Procedures) – In Section 10 (Public Safety), the OMSS Manual states that the HCA Manager of Water Resources Engineering shall

ensure that appropriate safety procedures are implemented to warn the public of potential hazards and/or restrict public access and that the dam operator must ensure access for unauthorized personnel during operations is prohibited, however, consideration for public safety is not included within Section 6 (Equipment, Tools and Safety Procedures). It is understood from staff on site that changes in flows are undertaken gradually, however this is not expressly written in the OMSS Manual.

The location of the existing public safety measures are shown in Figure 4 and the sign index is included in Appendix B.



Photo 35 – Public Safety Sign
Above Main Spillway



Photo 36 – Public Safety Sign
Low Flow Outlet



Photo 37 – Typical Railing



Photo 38 – Retaining Wall

6.2.5 Low Flow / Emergency Spillway

There are a number of public safety measures in place that have the potential to mitigate public safety hazards within the Low Flow / Emergency Spillway component area, including:

- Public Safety Signs – There are downstream facing public safety signs installed on the dam. The signs are located above main spillway (Photo 35) and the low flow outlet (Photo 36). The signs can be clearly seen from the Main Spillway and Low Flow / Emergency Spillway component areas.
- Security Patrols – Staff from the Christie Lake Conservation Area visit the site daily. It is understood that these visits are being undertaken at different times each day. This is a good practice to ensure that time-specific public activities are identified.
- Operational Controls (Procedures) – In Section 10 (Public Safety), the OMSS Manual states that the HCA Manager of Water Resources Engineering shall ensure that appropriate safety procedures are implemented to warn the public of potential hazards and/or restrict public access and that the dam operator must ensure access for unauthorized personnel during operations is prohibited, however, consideration for public safety is not included within Section 6 (Equipment, Tools and Safety Procedures). It is understood from staff on site that changes in flows are undertaken gradually, however this is not expressly written in the OMSS Manual.

The location of the existing public safety measures are shown in Figure 4 and the sign index is included in Appendix B.

6.2.6 Downstream Area

There is one (1) public safety measure in place that has the potential to mitigate public safety hazards within the Downstream Area component area, including:

- Operational Controls (Procedures) – In Section 10 (Public Safety), the OMSS Manual states that the HCA Manager of Water Resources Engineering shall ensure that appropriate safety procedures are implemented to warn the public of potential hazards and/or restrict public access and that the dam operator must ensure access for unauthorized personnel during operations is prohibited; however, consideration for public safety is not included within Section 6 (Equipment, Tools and Safety Procedures). It is understood from staff on site that changes in flows are undertaken gradually, however, this is not expressly written in the OMSS Manual. It is unclear from the documentation if HCA staff check this area prior to operating the dam and there is no audible signaling device.

There are areas further downstream that may be impacted by changing water levels and flows. A typical public safety sign is shown in Photo 39. It is understood that these (or similar) signs are installed at the Crooks Hollow Conservation Area, Greensville Optimist Park and Webster Falls.



Photo 39 – Downstream Public Safety Sign

6.2.7 Darnley Mills Ruins

There are a number of public safety measures in place that have the potential to mitigate public safety hazards within the Darnley Mill Ruins component area, including:

- Public Safety Signs – There are “No Trespassing” signs located at a number of locations around the exterior fencing (Photo 40) and a sign warning that the stone walls are in imminent danger of collapse located on the east wall of the mill ruins, adjacent to the Crooks Hollow Road bridge (Photo 41). The signs are generally in good condition; however, they do not surround the entire structure.
- Fencing/Railings – There is a fence that surrounds the majority of the mill ruins (Photo 42). A number of deficiencies were identified during the site visit. The end of the fencing on the northeast side of the mill structure stops short of the slope and does not return to the mill structure (Photo 43). This means that members of the public can simply walk around the fence to access the mill ruins. Other deficiencies with the fencing include bent sections and broken joints. Examples of these deficiencies are shown in Photos 44 and 45.

The location of the existing public safety measures are shown in Figure 4 and the sign index is included in Appendix B.



Photo 40 – Typical No Trespassing Sign



Photo 41 – Public Safety Sign



Photo 42 – Exterior Fencing



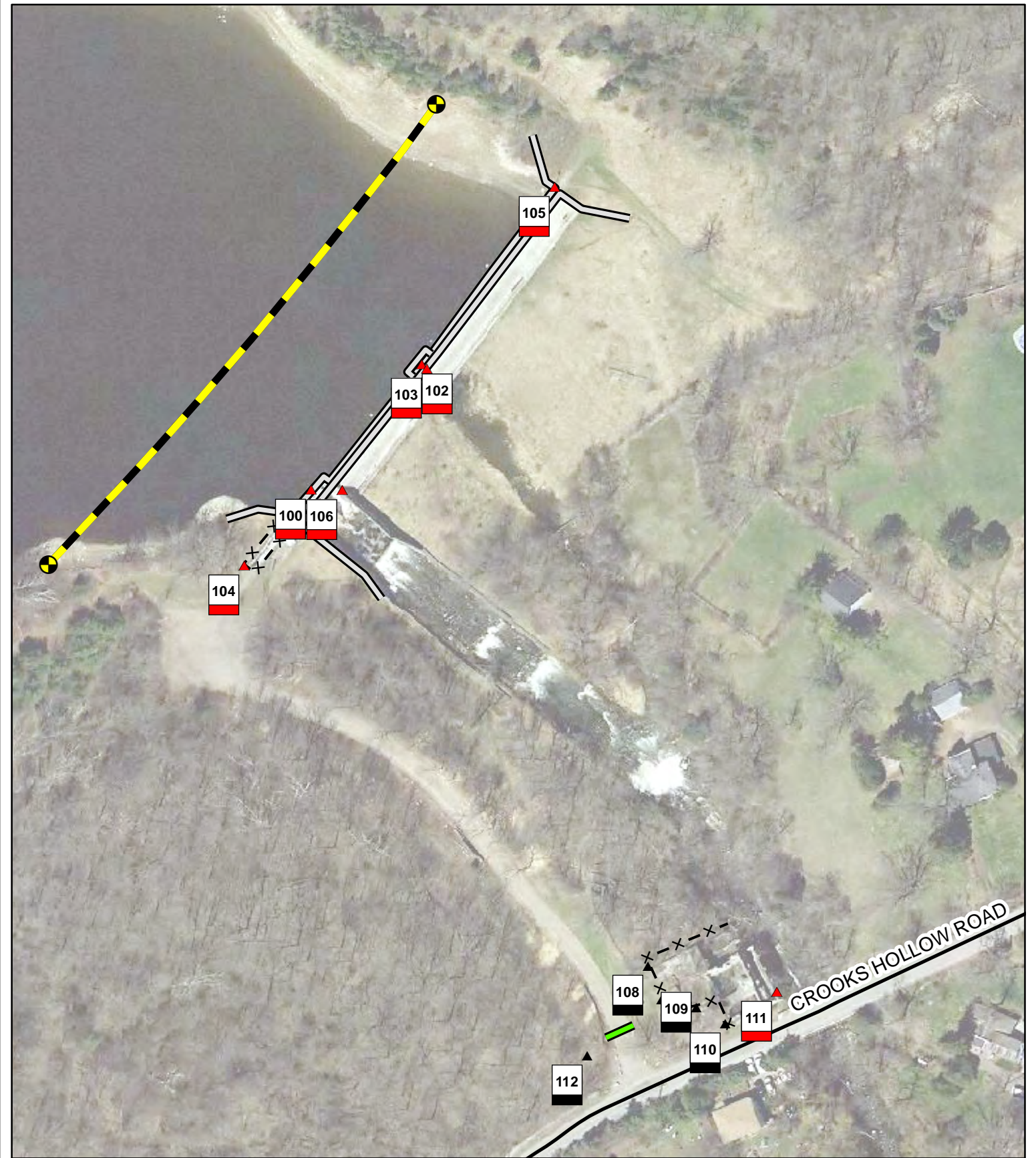
Photo 43 – End of Exterior Fencing



Photo 44 – Exterior Fencing Deficiency (Possible Evidence of Fence Climbing)



Photo 45 – Exterior Fencing Deficiency



Legend

- ▲ Information Sign
- ▲ Public Safety Sign
- Public Safety Boom Anchors
- ▬ Public Safety Boom Line
- ▬ Railing
- ▬ Access Gate
- × Fence

Data Sources
 Land Information Ontario 2020
 Created In: ArcMap 10.7

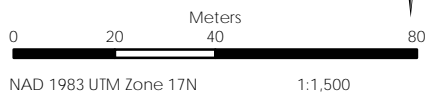


Figure 4 - Existing Public Safety Measures

Drawn By:	DG
Checked By:	DG
Map Date:	12/21/20
Project Number:	20-5426
Map File Number:	201109-5426



D.M. Wills Associates Limited
 150 Jameson Drive
 Peterborough, Ontario
 K9J 0B9
 P. 705.742.2297
 F. 705.748.9944
 E. wills@dmwills.com
 Copyright © D.M.Wills 2020

6.3 Opportunities for Improvement

A number of opportunities for improvement are detailed within the Final Public Safety Risk Assessment Report (Wills, 2021). The following is a summary of those recommendations:

Signage

- Upon installation of the new Public Safety Boom, place large signs (DANGER, Dam Ahead – Keep Out, Access Beyond This Point May Result In Drowning) at both shore anchor points. The signs should include appropriate pictographs.
- During all seasons where ice may be present on the reservoir, place small signs (DANGER, Thin Ice, Keep Off) at all possible public access points.
- Place three (3), equally spaced, small signs (DANGER, No Trespassing, Access Beyond This Point May Result In Drowning) on the left side of the emergency spillway. If the audible danger signalling device is installed, a separate panel (Siren Indicates Rapid Changes In Water Levels and Flow) should be added to the signs.
- Place medium signs (WARNING, Dam Upstream, Water Levels and Flow May Change Without Notice) at the main access points to the Darnley Cascade. If the audible danger signalling device is installed, a separate panel (Siren Indicates Rapid Changes In Water Levels and Flow) should be added to the signs.

Public Education (Local Initiatives)

- Warn members of the public of the hazards associated with the dam and its appurtenant structures as they enter the Christie Lake Conservation Area.

This warning could be an information sign (white background with black lettering) posted at the front gate, a verbal warning from Conservation Area staff or a written pamphlet handed out as people enter.

Safety Boom

- Replace the public safety boom with a permanent (i.e. installed year round) public safety boom that meets the current recommendations outlined in the Guidelines for Public Safety Around Dams (CDA, 2011) and other applicable regulatory requirements (i.e. Transport Canada).

The public safety boom should be yellow in colour and be designed so that the opportunity for swimmer self rescue is provided. Typically, this means that the boom is placed in an area of lower velocity (less than 0.6 m/s during high flow conditions) and that the boom should be either angled or have a middle anchor point, with no sags, so that stranded boaters or swimmers are directed towards shore.

Audible Danger Signaling Device

- Install an audible danger signalling device, in accordance with the Technical Bulletin: Audible and Visual Signals for Public Safety Around Dams (CDA, 2011), to warn members of the public downstream of pending changes in water levels and flows. The audible danger signaling device should be heard at least as far downstream as Crooks Hollow Road.

As an alternate to installing the audible danger signalling device, HCA's operational practice of looking downstream before operating the dam could be modified to including checking the Darnley Cascade for members of the public.

Fencing/Railings/Barricades

- If the new public safety boom and associated signage doesn't have the desired effect of reducing the number of people within the Headpond area, install new fencing (minimum 7 ft. high) that extends from the ends of the upstream concrete wingwalls to the downstream side of the public safety boom. The ends of the fencing should have cantilevered sections that extend over the water.
- Install a lockable gate/cover on the ladder that provides access to the drop inlet structure deck.
- Install railings that meet Ontario Building Code requirements, along the top of the gabion basket retaining walls in the Main Spillway component area.

Security Patrols

- Continue the current practice of undertaking security patrols. Ensure that the security patrols are undertaken on a random basis (i.e. not the same time each day) in order to identify activities that may be undertaken at specific times.
- Document all public activities (both allowed and prohibited) and public safety incidents using the CDA Public Safety Incident Report form included in Appendix A and develop a spreadsheet to track the public safety activities for reference as part of future PSRAs.

Video Surveillance

- Replace the broken security camera on the control building.

Ideally, security cameras would have view of the Headpond, Structure, Main Spillway and Low Flow / Emergency Spillway component areas.

Operational Controls (Procedures)

- Update the OMSS Manual, as follows:
 - Add to all appropriate procedures, the requirement to check the Headpond, Structure, Low Flow/Emergency Spillway, Main Spillway and Downstream Area component areas for members of the public prior to undertaking any operations.
 - Include procedures for how to deal with members of the public in the event of their presence when the dam needs to be operated.

- Add to all appropriate procedures, the requirement to increase flows gradually (i.e. using a stepped approach).
- Update the Section 9 (Records) and/or Section 10 (Public Safety) to include the requirement for HCA staff to record and report public safety activities and incidents. The public safety activities/incidents can be documented using a Microsoft Excel spreadsheet. The CDA Public Safety Incident Report form should be used to record and document all incidents.
- Add considerations for the use of the audible danger signalling device, if one is installed as per the recommendations, or, as an alternate, for checking the Darnley Cascade for members of the public prior to operation.

Darnley Mill Ruins Public Safety Improvements

- Replace or improve the existing fencing to ensure that members of the public cannot access the mill ruins.

Fencing should be a minimum of 7 ft. high and there should be no breaks or gaps that would allow members of the public to access the site.
- Place small signs (NO TRESPASSING) at least every 10 m around the fencing and at all fence corners and gates.
- Place small signs (DANGER, Stone Walls In Imminent Danger of Collapse) alongside all NO TRESPASSING signs.
- Identify all websites that are promoting prohibited activities at the Darnley Mill Ruins and work with the owners of those sites to have specific posts removed in order to reduce the traffic to the site.

If the website owners are not willing to remove content, the HCA could try to have them post warnings on their sites identifying potential hazards associated with accessing the mill ruins.
- Install a cover or grate on the former steel penstock to prevent members of the public from climbing into it.

It is noted that a number of these recommendations have already been implemented or will be implemented in the near future, including:

- Installation of large signs (DANGER, Dam Ahead – Keep Out, Access Beyond This Point May Result In Drowning) at both shore anchor points of the public safety boom.
- Installation of small signs (DANGER, Thin Ice, Keep Off) at all possible public access points. To be present in winter only.
- Installation of three (3) small signs (DANGER, No Trespassing, Access Beyond This Point May Result In Drowning) on the left side of the emergency spillway.

- Installation of medium signs (WARNING, Dam Upstream, Water Levels and Flow May Change Without Notice) at the main access points to the Darnley Cascade.
- Replacement of the public safety boom with a permanent (i.e. installed year round) public safety boom that meets the current recommendations outlined in the Guidelines for Public Safety Around Dams (CDA, 2011) and other applicable regulatory requirements (i.e. Transport Canada).
- Installation of fencing along the top of the gabion basket retaining walls in the Main Spillway component area.
- Installation of a lockable gate/cover on the ladder that provides access to the drop inlet structure deck.

These additional public safety measures will be identified and considered at the next update/review of the PSRA and PSP.

7.0 Inspection and Maintenance Program

Although observations by staff or others can provide input at any time during the year, annual inspections of the public safety measures at the Christie Lake Dam shall be made and documented on a schedule established by the Director, Watershed Management Practices. It is good practice, when weather and access permit, to inspect the facilities early in the year. In doing so, it will provide sufficient time to complete any repairs or public safety enhancements prior to the summer season. The inspection and maintenance for the public safety measures should include the items described in Table 2, as applicable.

Table 2 – Inspection and Maintenance Requirements

Item	Inspect For	Required Action or Maintenance
Upstream and Downstream Areas	<ul style="list-style-type: none"> • Public presence. 	Notify the public of the hazards created by the dam and its operation.
Signage	<ul style="list-style-type: none"> • All signs are present and accounted for. • Securely mounted. • Clear and understandable. • Visible (limiting factors could include vegetation, size of lettering, snow cover, etc.). • Condition (vandalized, damaged, etc.). 	Replace damaged or missing signs, secure loose signs, remove debris and graffiti, clear vegetation in front of signs.
Fences and Gates	<ul style="list-style-type: none"> • Upright and secure. • No holes or missing sections. 	Repair or replace damaged fencing or gates.

Item	Inspect For	Required Action or Maintenance
	<ul style="list-style-type: none"> No holes under fence. No paths established around fence. No vegetation overgrowing fence. 	
Railings	<ul style="list-style-type: none"> Structural degradation. Signs of corrosion. Loose anchor bolts. Vandalism. 	Repair and paint.
Safety Boom and Buoys	<ul style="list-style-type: none"> Cables and anchors secure. Boom forms a continuous barrier. Debris accumulation. Damaged floatation units. 	Remove debris, provide temporary repair solutions and additional signage in the event of boom failure, replace damaged or worn parts and components.
Sirens and Warning Lights	<ul style="list-style-type: none"> Functioning as intended. Can be seen / heard from the appropriate distances. 	Repair or replace parts that are not functioning properly, tune volume settings.
Security System and Cameras	<ul style="list-style-type: none"> Function of security system and cameras. Cameras cover key areas of the dam site. 	Repair system and replace parts, change the camera angles to ensure proper site coverage.

The annual inspections of the public safety measures shall be documented in order to help establish due diligence. Consistent documentation of the annual inspections could help to identify chronic maintenance issues that affect public safety and could indicate where more attention to some aspects of the PSMP is required. The documentation of the inspections should include the:

- Date of the inspection and name of the person performing it.
- Public safety measures inspected and their current condition.
- Corrective actions necessary and confirmation of any corrective actions taken.
- Adherence of each public safety measure to the current codes and best practices.

Regardless of the initiating factor, the prompt and effective remedy of any deficiency in public safety controls is regarded as a priority; therefore, during inspections, the individual discovering an unsafe condition or an unreliable control device will, if possible, immediately remedy the deficiency. If a safety control device fails, the

Inspector will complete and file a deficiency report. If the Inspector cannot remedy the deficiency at the time of inspection, it is the responsibility of the Inspector to:

1. Implement interim safety measures and notify the Director, Watershed Management Services so that full repair can be properly undertaken.
2. Complete the Safety Control Deficiency and Remediation Report (included in Appendix A) and forward it to the Director, Watershed Management Services who will file the report to document all remediation measures.
3. Record any breakage, loss, or failure of a safety control due to vandalism, or other causes, including fallen trees, erosion, high water levels, motor vehicle incidents, acts of trespass into Danger zones, etc.
4. If a safety control fails, mark up the appropriate map to show the specific location of the item to be addressed and describe in the comment section of the Safety Control Deficiency and Remediation Report what the issue is.

Repairs that pose a health and safety risk to the inspector shall not be undertaken as part of the inspection and maintenance program. It is the responsibility of the inspector to determine if the repairs required exist outside their expertise and scope of work. All maintenance items shall be reported to the Director, Watershed Management Services and appropriate actions shall be taken to rectify the deficiencies.

8.0 Public Education Plan

The HCA should implement initiatives that promote public safety and awareness at the site. The initiatives should:

- Inform the public about the risks and hazards related to the dam.
- Communicate roles and responsibilities of the public with respect to following signage and respecting the limits placed by physical control measures.
- Either notify the public or raise their awareness in regard to hazards identified at the site, for example:
 - Safety focused newsletters or pamphlets.
 - Information signs at the entrance of Christie Lake Conservation Area.
 - Verbal information/warning from Conservation Area staff.
 - Targeted social media advertising.
 - Information made available on the HCA's website and social media channels.
 - Coordination and communication with local authorities such as the NDMNRF and OPP, local media and other stakeholders, as appropriate.
- How the public can report any concerns about public safety.

Examples of Public Notifications are shown in Appendix C for the HCA's consideration. These types of notifications could be placed in the newspaper, on the radio and on social media prior to spring/summer. Another Public Notification may be used prior to the winter recreation season to include the hazards of thin ice on the reservoir.

9.0 Incident Reporting

The HCA shall document any public safety incidents involving members of the public. An incident is defined as the potential or actual interaction between a member of the public and a hazard associated with the dam or its operation. This documentation should be used to inform the review and update of the Public Safety Risk Assessment and this PSP. Each incident report should contain, at a minimum, the following information:

- Date and approximate time of incident.
- Location of incident.
- Type of incident.
- Activities and sequence of events that led to the incident.
- Description of any response actions taken.
- Description of any resulting injury.

The Canadian Dam Association Public Safety Incident Report form, included in Appendix A, should be used to document any public safety incidents. All incidents should be reported to the Director, Watershed Management Services. Serious incidents should be reported immediately. Other incidents should be reported on a monthly basis.

10.0 Record Management

This document, the Christie Lake Dam Public Safety Plan, is meant to be a living document and needs to be updated as changes occur at the site. Examples of situations where an update to the Public Safety Risk Assessment and Public Safety Plan may be required include:

- Changes in the degree of public interaction.
- Changes in the potential consequences for a specific public interaction.
- New construction at the site which creates a change in operation.
- Identification of new public interactions.
- Changes in operating procedures.

As a minimum standard, the HCA should maintain and keep the following documentation up-to-date:

- Public Safety Plan (this document).
- Public Safety Risk Assessment.
- Public safety incident reports.
- Maintenance and inspection reports.

It is recommended that the HCA review the effectiveness of the PSP on an annual basis, whenever a new issue is observed or whenever a change at the site (as described above) occurs. The HCA should have the PSP independently reviewed every five (5) years.

The HCA should retain all records and documents for a minimum of two (2) PSRA/PSP review cycles (i.e. 10 years).

Appendix A

Forms and Reports



Public Safety Incident Report

1.0 Incident Identification	1.1 Site or Dam Name:	1.2 Incident Date (mm/dd/yy):	1.2 Incident Time: <input type="checkbox"/> AM <input type="checkbox"/> PM	
	1.4 River Name:			
	1.5 Location of Incident:			
	<input type="checkbox"/> Upstream (specific location) <input type="checkbox"/> Penstock <input type="checkbox"/> Authorized public access area <input type="checkbox"/> Headpond <input type="checkbox"/> Spillway <input type="checkbox"/> Boat Ramp(s) <input type="checkbox"/> Dam (e.g. Crest, Roof, Deck) <input type="checkbox"/> Intakes <input type="checkbox"/> Tailrace (designated dangerous area) <input type="checkbox"/> Roadways <input type="checkbox"/> Downstream (specific location) <input type="checkbox"/> Other:			
	1.6 Incident Type:			
	<input type="checkbox"/> Fatality (not a suicide or homicide) <input type="checkbox"/> Trespassing or otherwise entering into a dangerous area <input type="checkbox"/> Injury <input type="checkbox"/> Failure of a physical control measure <input type="checkbox"/> Stranding/rescue <input type="checkbox"/> Failure to follow operating procedures <input type="checkbox"/> Other:			
	1.7 Names of Individuals Involved (if known):		1.8 Names of Eyewitnesses:	
	1.9 Name of First Aid Responder:			
	1.10 Name of Hospital/Clinic:			
	1.11 Name of Responding Police Officer:		1.12 Police Report Number (if applicable):	
2.0 Description of Incident	2.1 Incident Description:			
	2.2 Describe the sequence of events leading to the incident and any injuries that resulted: (Include observations by staff at site, resultant discussion with member(s) of the public, if any etc.)			

Public Safety Incident Report

3.0 Activities	3.1 What was the Persons(s) doing at the time of the injury/incident? From Water / Ice <input type="checkbox"/> Fishing from Boat <input type="checkbox"/> Boating (under power) <input type="checkbox"/> Sailing <input type="checkbox"/> Windsurfing <input type="checkbox"/> Canoeing/Kayaking/Rowing <input type="checkbox"/> Waterskiing <input type="checkbox"/> Swimming <input type="checkbox"/> Jet Ski <input type="checkbox"/> Scuba Diving <input type="checkbox"/> Swimming/Diving <input type="checkbox"/> Skating <input type="checkbox"/> Ice Fishing <input type="checkbox"/> Snowmobiling <input type="checkbox"/> Other: <input type="checkbox"/> Unknown From Shore / Structure <input type="checkbox"/> Fishing from Shore <input type="checkbox"/> Walking <input type="checkbox"/> Climbing <input type="checkbox"/> Picnicking <input type="checkbox"/> ATV / Dirt Biking <input type="checkbox"/> Hiking <input type="checkbox"/> Skiing <input type="checkbox"/> Snowshoeing <input type="checkbox"/> Driving <input type="checkbox"/> Biking <input type="checkbox"/> Scuba Diving <input type="checkbox"/> Swimming/Diving <input type="checkbox"/> Accessing electrical equipment <input type="checkbox"/> Accessing mechanical equipment <input type="checkbox"/> Other: <input type="checkbox"/> Unknown <input type="checkbox"/> Trespassing		
4.0 Control Measures	4.1 Select Physical Control Measures in place at time of the incident: <input type="checkbox"/> N/A <input type="checkbox"/> Signage <input type="checkbox"/> Public Education (local) <input type="checkbox"/> Safety Buoys <input type="checkbox"/> Safety Booms <input type="checkbox"/> Video Surveillance <input type="checkbox"/> Visual Danger Signal Device <input type="checkbox"/> Fencing <input type="checkbox"/> Vehicle Barricades <input type="checkbox"/> Security Patrols <input type="checkbox"/> Audible Danger Signaling Devices <input type="checkbox"/> Operational Control Procedure <input type="checkbox"/> Other:		
5.0 Environmental	5.1 Select the Physical / Environmental Factor(s) relevant to the incident <input type="checkbox"/> N/A Physical <input type="checkbox"/> Slope Instability <input type="checkbox"/> Rapid Water Rise <input type="checkbox"/> Inaccessible Location <input type="checkbox"/> Steep Slopes <input type="checkbox"/> Sudden Release of Water <input type="checkbox"/> Exposed Equipment <input type="checkbox"/> Uneven Surfaces <input type="checkbox"/> Remote Release of Water <input type="checkbox"/> Sharp Objects <input type="checkbox"/> Slippery Surfaces <input type="checkbox"/> Ramped Release of Water <input type="checkbox"/> Structural Failure <input type="checkbox"/> Strong Currents/Undertow <input type="checkbox"/> Floating Debris <input type="checkbox"/> Energized Equipment <input type="checkbox"/> Failure of Vehicle or Vessel <input type="checkbox"/> Failure of Ice Cover <input type="checkbox"/> Other: Environmental <input type="checkbox"/> Cold Environment <input type="checkbox"/> Windy Conditions <input type="checkbox"/> Other: <input type="checkbox"/> Hot Environment <input type="checkbox"/> Dark, Night Conditions <input type="checkbox"/> Rainy Conditions <input type="checkbox"/> Low Lighting <input type="checkbox"/> Snow/Ice <input type="checkbox"/> Low Visibility		
6.0 Corrective Measures	6.1 Describe any Immediate Action(s) Taken as a result of the incident. (i.e. Corrective actions, warnings issued, charges laid, control measure repaired or upgraded, procedures written I amended)		
7.0 Contact Information	7.1 Contact Person on Site:	7.2 Submitted by:	







Appendix B

Sign Index















Sign Index – Christie Lake Dam




Updated April 14, 2022

Sign ID	Sign	Size	Location	Photo
100		36" x 84"	Facing upstream at Main Spillway	
101		36" x 84"	Facing downstream at Main Spillway	
102		36" x 84"	Facing upstream at Drop Inlet Structure	
103		36" x 84"	Facing downstream at Drop Inlet Structure	

Sign ID	Sign	Size	Location	Photo
104		12" x 20"	Approach from right side	
105		12" x 20"	Approach from left side	
106		TBC	Right aide of Emergency Spillway	
107		12" x 20"	Fencing Around Darnley Mill ruins	

Sign ID	Sign	Size	Location	Photo
108		12" x 20"	Fencing around Darnley Mill ruins	
109		12" x 20"	Fencing around Darnley Mill ruins	
110		12" x 20"	Fencing around Darnley Mill ruins	
111	Not available	TBC	East side of Darnley Mill structure	

Sign ID	Sign	Size	Location	Photo
112	Not available	12" x 20"	Left side of entrance driveway	
113		42" x 94"	At upstream left public safety boom anchor	TBC
114		42" x 94"	At upstream right public safety boom anchor	TBC
115		18" x 30"	Left side of Emergency Spillway	TBC
116		18" x 30"	Left side of Emergency Spillway	TBC

Sign ID	Sign	Size	Location	Photo
117		18" x 30"	Left side of Emergency Spillway	TBC
118		30" x 54"	Darnley Cascade	TBC
119		30" x 54"	Darnley Cascade	TBC

Appendix C

Sample Notifications



Example Public Notification 1 – Reservoir, Summer

<p>Safety on Reservoirs Christie Lake Dam and Christie Lake</p>
<p>Warning</p> <p>Play it safe when visiting the Christie Lake Dam and Christie Lake.</p> <p>Christie Lake in the vicinity of the Christie Lake Dam can be an enjoyable recreational destination, provided certain safety precautions are observed.</p> <p>Boating, fishing and swimming above or below the dam can be very dangerous. For your own safety and the safety of those with you, obey all warning signs and stay out of all restricted areas.</p> <p>Boaters must comply with all Canadian Coast Guard regulations and practice safe boating at all times.</p> <p>When boating please wear your life jacket (personal floatation device, PFD)</p> <p>Hamilton Conservation Authority</p>

Example Public Notification 2 – Reservoir, Winter

<p>Safety on Reservoirs Christie Lake Dam and Christie Lake</p>
<p>Warning</p> <p>Play it safe when visiting the Christie Lake Dam and Christie Lake this winter.</p> <p>Christie Lake upstream of the Christie Lake Dam can be an enjoyable recreational destination, provided certain safety precautions are observed.</p> <p>Flowing water may cause thin ice in areas immediately upstream of the dam. The ice thickness is not monitored by Hamilton Conservation Authority staff and engaging in activities on the ice could be dangerous.</p> <p>Please stay off the ice.</p> <p>Hamilton Conservation Authority</p>

Example Public Notification 3 – Safety Around Dams, General

<p>Safety Around Dams Christie Lake Dam</p>
<p>An important message for visitors</p> <p>Hamilton Conservation Authority's dam facilities can be interesting places to visit, provided certain precautions are observed.</p> <p>Water control structures and dams, and the areas nearby can be dangerous to the unwary or the adventurous. Some hazards are readily apparent but others are not. Some hazards such as water flows immediately upstream of a dam may seem calm and safe to be in, but they are not. Instead, water flow immediately upstream of a water control structure is dangerous and contains strong currents and undertows that can easily cause a person who enters the water to drown.</p> <p>Visitors should stay well clear of dams, water intake and conveyance structures, powerhouses, discharge channels and all electrical, mechanical and monitoring equipment. Areas of water immediately upstream and downstream of dams and generating facilities are hazardous.</p> <p>Please respect fenced and gated areas and observe all posted signs. Stay on designated trails and be sure to supervise children closely.</p> <p>For further information about our operations, please visit our website at www.conservationhamilton.ca.</p> <p>Have a safe and informative visit!</p> <p>Hamilton Conservation Authority</p>

APPENDIX C.2

Valens Lake Dams
Public Safety Plans



Draft Public Safety Plan

Valens Lake Dam

Hamilton, Ontario

D.M. Wills Project Number 20-5426



D.M. Wills Associates Limited
Partners in Engineering, Planning and
Environmental Services
Peterborough



April 2022

Prepared for:
Hamilton Conservation Authority

Summary of Revisions

Rev. No.	Revision Title	Date	Summary of Revisions
1	Draft PSP	April 14, 2022	Issued for Client Review

This report/proposal has been formatted considering the requirements of the Accessibility for Ontarians with Disabilities Act.

Draft

Authorization

This document has been developed to document the public safety measures at the Valens Lake Dam in Hamilton, Ontario

Prepared by:

David Green, P.Eng.
Assistant Manager, Water Resources Engineering
D.M. Wills Associates Limited

Date:

Approved by:

Scott Peck, MCIP, RPP
Deputy Chief Administrative Officer /
Director, Watershed Management Services
Hamilton Conservation Authority

Date:

Draft

Table of Contents

1.0	Introduction	5
2.0	Purpose	5
2.1	Topics Covered by the Public Safety Plan	5
2.2	Topics NOT Covered by the Public Safety Plan.....	6
3.0	Roles and Responsibilities.....	6
3.1	Hamilton Conservation Authority	6
3.2	Management Staff	6
4.0	Site Description.....	7
4.1	Site Location	7
4.2	General Site Layout	7
4.3	Operational Procedures	9
5.0	Risk Assessment Summary.....	12
5.1	Component Areas.....	12
5.2	Public Activities and Potential Hazards	14
5.3	Risk Levels.....	15
6.0	Existing Control Measures and Opportunities for Improvement.....	16
6.1	Overview of Public Safety Control Measures Purpose	16
6.2	Existing Control Measures	16
6.2.1	Upstream Area	16
6.2.2	Headpond.....	17
6.2.3	Structure.....	18
6.2.4	Tailrace.....	19
6.2.5	Downstream Area	20
6.3	Opportunities for Improvement	22
7.0	Inspection and Maintenance Program	24
8.0	Public Education Plan	26
9.0	Incident Reporting.....	27
10.0	Record Management	27

Figures

Figure 1 – Location Plan.....	10
Figure 2 – General Site Plan.....	11
Figure 3 – Component Areas.....	13
Figure 4 – Existing Public Safety Measures.....	21

Tables

Table 1 – Public Activities and Potential Hazards.....	14
Table 2 – Inspection and Maintenance Requirements.....	24

Appendices

Appendix A - Forms and Reports
Appendix B - Sign Index
Appendix C - Sample Public Notifications

Draft

1.0 Introduction

D.M. Wills Associates Limited (Wills) was retained by the Hamilton Conservation Authority (HCA) to complete a Public Safety Plan (PSP) for the Valens Lake Dam. This PSP has been prepared in accordance with the Canadian Dam Association (CDA) Guidelines for Public Safety Around Dams (CDA, 2011) and considers the Best Management Practices for Public Safety Around Dams (MNR, 2011).

The PSP utilizes information obtained through a site visit that was completed by Wills and the HCA on November 17, 2020. The public safety hazards, risk levels and risk reduction recommendations contained in this PSP are a summary, based on information documented within the Final Public Safety Risk Assessment Report dated March 2021.

Electronic copies of this PSP are held in the HCA's and Wills' files. Hardcopies have not been distributed.

2.0 Purpose

This document has been developed for two (2) purposes:

1. Summarize the hazards associated with the dam and its operation, describe the risks associated with the hazards and recommend control measure that, when implemented, will eliminate or reduce the risk of public injury or death during normal operations.
2. Outline the roles, responsibilities, procedures and timelines that are required in order for the HCA to demonstrate public safety due diligence.

2.1 Topics Covered by the Public Safety Plan

The following topics are covered in this PSP:

- Roles and responsibilities of the HCA;
- A description of the facility to which this PSP applies;
- Risk Assessment summary, including:
 - Public activities in the areas affected by the facility;
 - Hazards to the public that may be present;
 - Safety control measures that are currently employed to protect the public during normal operations;
 - Safety control measures that, when implemented, will address public safety hazards and risks created by normal operation;
- Procedures for inspection, remediation and modification of safety controls;
- Relevant mapping of the component areas;

- Sign index, or future sign index;
- Sign inventory for inspection purposes (example only);
- Public education;
- Records management; and
- Incident reporting.

2.2 Topics NOT Covered by the Public Safety Plan

The following topics are NOT covered in this PSP:

- Areas outside of the component area boundaries, including Valens Lake;
- Private property;
- Properties under the control of a third party (i.e. properties leased to a third party) that are unaffected by the dam or its operations; and
- Property owned by the Crown or others including public roads and provincial, municipal and conservation area lands and facilities that are unaffected by the dam or its operation.

This PSP is applicable throughout the range of normal operating conditions. Situations outside of the range of normal operations (e.g. spilling, summer drawdowns for maintenance) are the subject of separate protocols, which supersede this PSP.

The term "public" does NOT refer to HCA staff or contractors working for the HCA. Safety practices for these workers are to be managed in accordance with the requirements of the Occupational Health and Safety Act and its applicable Regulations and the HCA's health and safety policies.

3.0 Roles and Responsibilities

3.1 Hamilton Conservation Authority

The HCA has an obligation to:

- Understand public use within areas affected by the operation of its facilities;
- Identify the hazards and risks involved with public use of areas affected by the HCA's assets and their operations; and
- Take all reasonably appropriate steps to remove or, where that is not possible, to reduce the public safety risks.

3.2 Management Staff

HCA Management Staff are responsible for ensuring that a PSP is prepared, implemented and maintained. Specifically, Management Staff are responsible for ensuring that:

- A PSP is in place and aligns with the requirements of the HCA's public safety policies;
- Inspections and remedial measures are performed, as required, under the PSP;
- Records are kept of inspections and remedial measures;
- Training is conducted so that staff involved can fulfill their respective roles and responsibilities;
- Safety controls are implemented or modified when changes to the physical structure or operating procedures may create an additional or modified public safety risk;
- Monitoring compliance with the PSP; and
- Revisions to the PSP are performed as and when required, and that revised pages are sent for revisions of the digital copy and subsequent updates to PSP websites if applicable.

4.0 Site Description

4.1 Site Location

The Valens Lake Dam is located on Lot 24, Concession 9 in the Geographic Township of Beverly in the City of Hamilton, Ontario. The dam controls the discharge from Valens Lake into Spencer Creek, which ultimately discharges into Lake Ontario. The primary access to the dam (north side) is via an access driveway from Valens Road. The access driveway passes a private dwelling that is owned by HCA but rented to a tenant. There is also a secondary access to the dam (south side) through the Valens Lake Conservation Area. The main gate for the Valens Lake Conservation Area is off Hamilton Regional Road 97. The location of the dam site is shown in Figure 1.

The dam and lake are part of the Valens Lake Conservation Area, which is owned by the HCA. The Valens Lake Conservation Area provides a number of recreational facilities, including trails, picnic areas, fishing, camping, boat launch/rentals and a swimming beach. The trail system provides access to the majority of areas on the property.

4.2 General Site Layout

The Valens Lake Dam was constructed in 1966 and underwent major maintenance, including embankment repairs/improvements and public safety upgrades, in 2005. The dam provides water level and discharge control for the purposes of low flow augmentation, flood control, recreation and habitat creation. The dam is located within the Valens Lake Conservation Area. The general site plan for the dam site is provided in Figure 2.

The Valens Lake Dam site is comprised of the following key elements:

- An access driveway, an access road across the top of the dam (Photo 1) and a parking area on the right side of the dam (Photo 2).
- An approximately 122 m long, 6.5 m high earth embankment (Photos 3 and 4).
- A concrete drop inlet structure with removable stoplogs (Photo 5).
- A low flow intake controlled by a valve (Photo 6).
- An outlet structure and tailrace channel (Photos 7 and 8).
- A conservation area that includes a number of recreational facilities, including trails, picnic areas, fishing, camping, boat launch/rentals and a swimming beach.



Photo 1 – Access Road Across Dam



Photo 2 – Parking Area on Right Side



Photo 3 – Downstream Earth Embankment



Photo 4 – Upstream Earth Embankment



Photo 5 – Concrete Inlet Structure



Photo 6 – Low Flow Valve Stem



Photo 7 – Outlet Structure



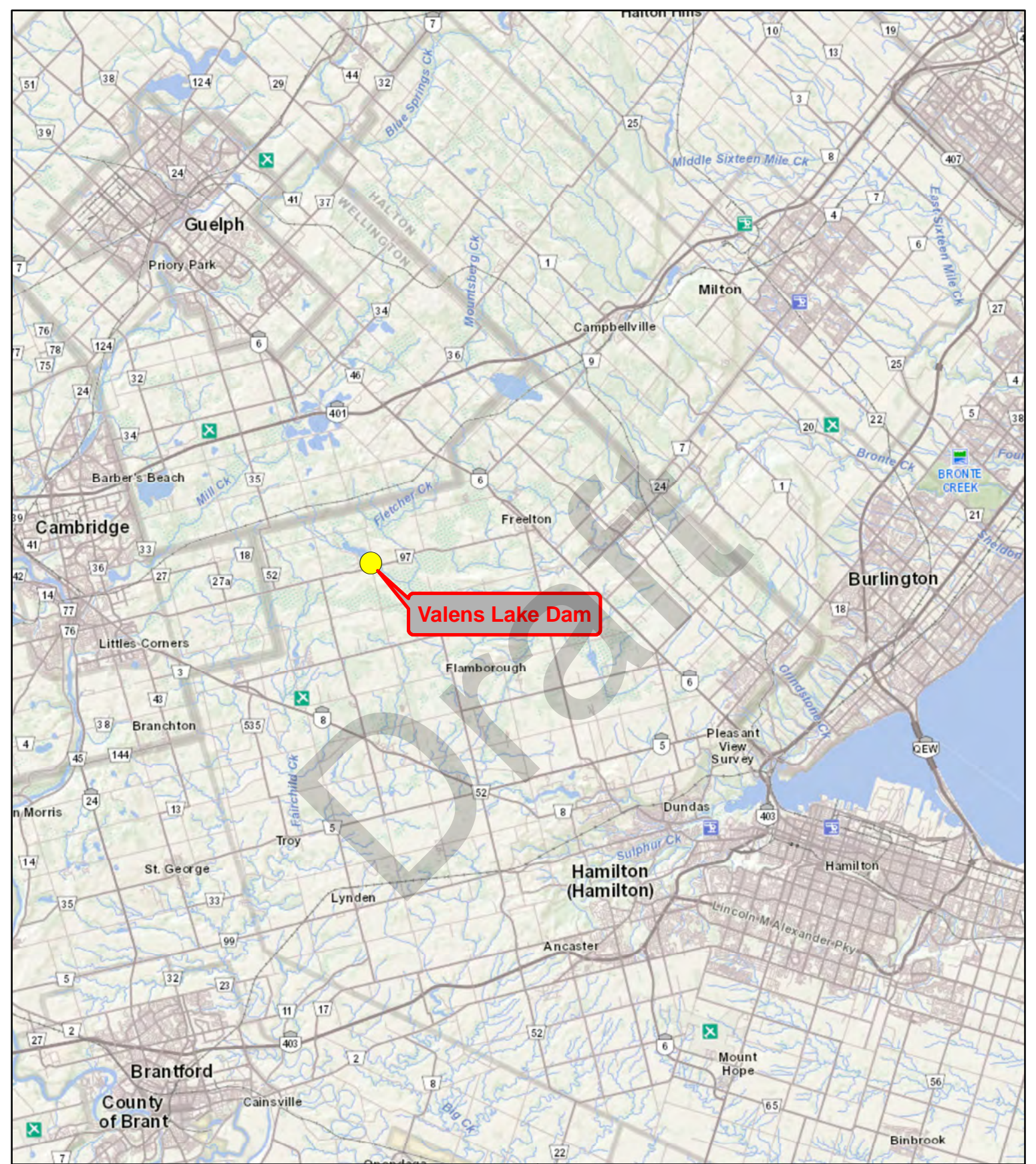
Photo 8 – Tailrace Channel

4.3 Operational Procedures

The dam is operated by HCA operations staff. The types of operations conducted at the site include:


- Seasonal operations of the various flow control equipment/structures.
- Emergency operations of the various flow control equipment/structures.
- Removal of debris and ice.

Dam operations are conducted in accordance with the Operation, Maintenance, Surveillance and Safety Manual (Hamilton Conservation Authority, undated).



Valens Lake Dam

Legend

 Valens Lake Dam

Data Sources
Land Information Ontario 2020
Created In: ArcMap 10.7

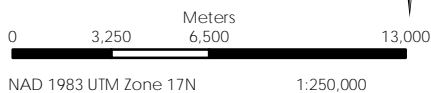


Figure 1 - Location Plan

Drawn By:	DG
Checked By:	DG
Map Date:	12/14/20
Project Number:	20-5426
File Number:	20201214-5426



D.M. Wills Associates Limited
150 Jameson Drive
Peterborough, Ontario
K9J 0B9

P. 705.742.2297
F. 705.748.9944
E. wills@dmwills.com
Copyright © D.M. Wills 2020



Upstream Area
1:20,000

- Legend**
- HCA Property Ownership
 - Arterial
 - Local

Data Sources
Land Information Ontario 2020
Created In: ArcMap 10.7

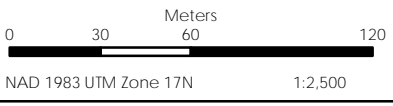


Figure 2 - General Site Plan

Drawn By:	DG
Checked By:	DG
Map Date:	12/21/20
Project Number:	20-5426
Map File Number:	201221-5426



D.M. Wills Associates Limited
150 Jameson Drive
Peterborough, Ontario
K9J 0B9

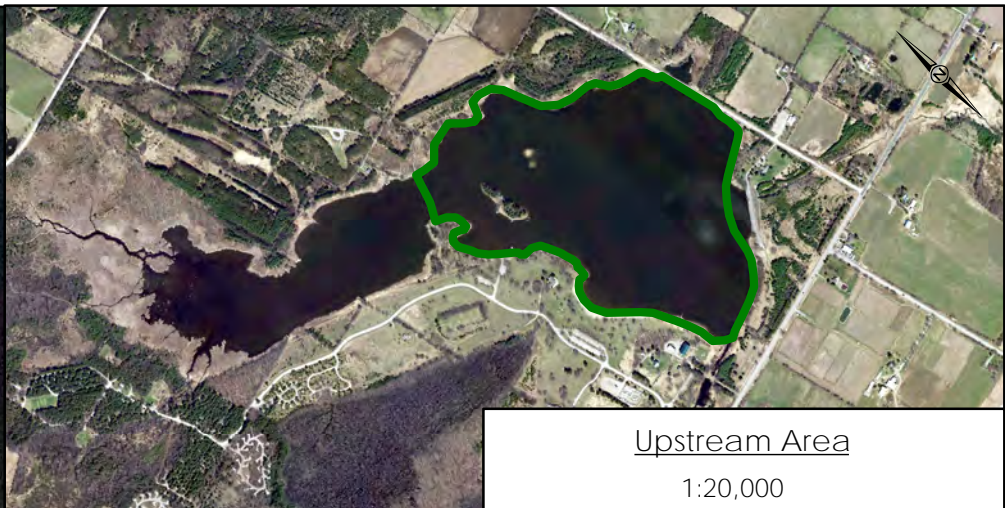
P. 705.742.2297
F. 705.748.9944
E. wills@dmwills.com
Copyright © D.M.Wills 2020

5.0 Risk Assessment Summary

5.1 Component Areas

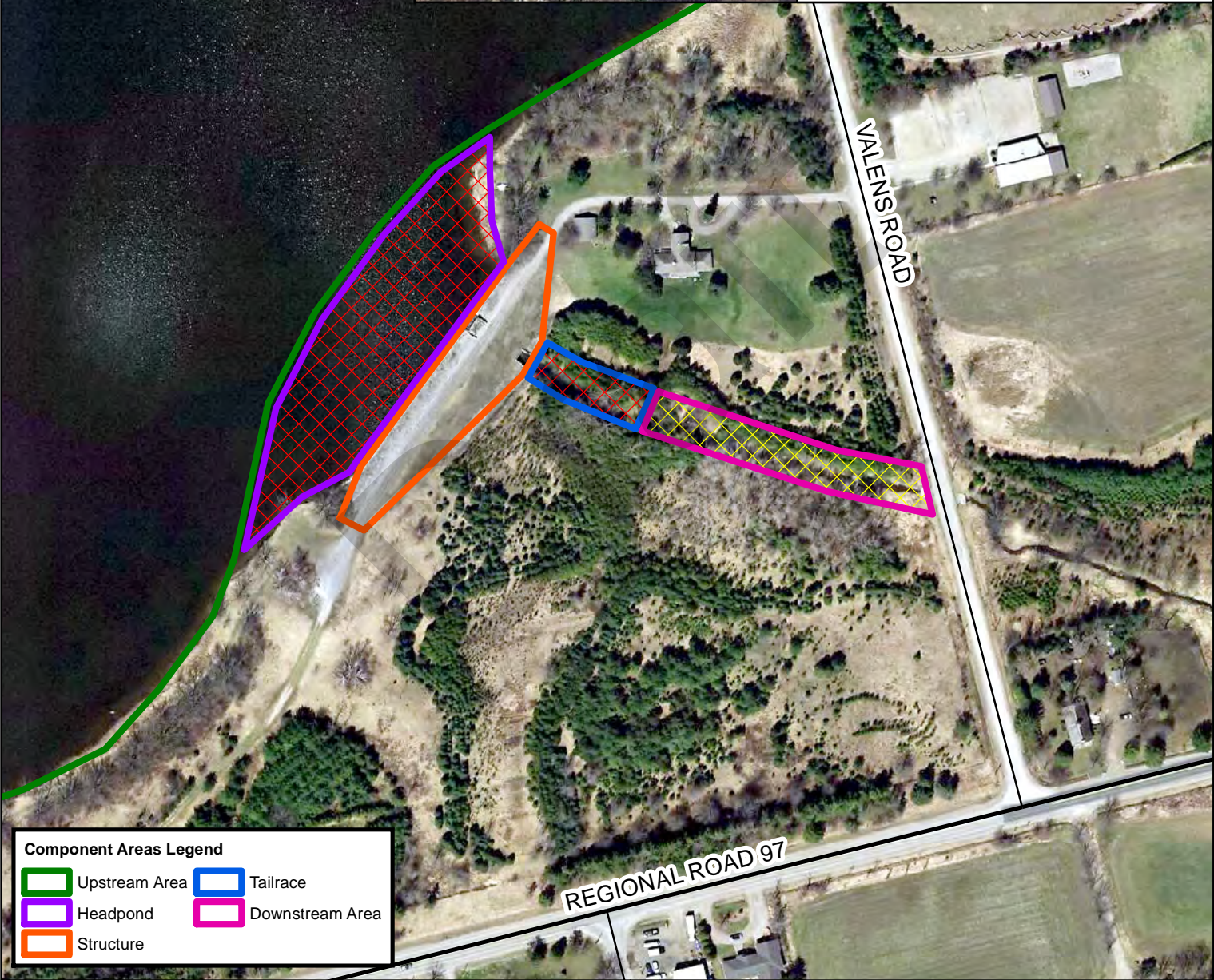
As shown in Figure 3 and described in the Final Public Safety Risk Assessment Report (Wills, 2021), the Valens Lake Dam site has been divided into five (5) main components, namely:

1. Upstream Area: The Upstream Area component area boundary extends from the upstream side of the Headpond component boundary to the downstream side of the trail/boardwalk crossing of the Valens Reservoir (~230 m) and encompasses the reservoir shoreline to a distance of 2 m back from the water's edge.
2. Headpond: The Headpond component area boundary extends from the upstream side of the dam to a distance of approximately 40 m upstream of the dam and encompasses the reservoir shoreline to a distance of 2 m back from the water's edge.
3. Structure: The Structure component area boundary includes the earth embankment structure and any associated flow control devices or equipment.
4. Tailrace: The Tailrace component area boundary extends from the downstream side of the dam to a distance approximately 50 m from the dam with a width of approximately 20 m centered on the centre of the watercourse.
5. Downstream Area: The Downstream Area component area boundary extends from the downstream side of the Tailrace component area boundary to the upstream side of Valens Road (~120 m) with a width of approximately 20 m centered on the center of the watercourse.



Upstream Area

1:20,000



Component Areas Legend

Upstream Area	Tailrace
Headpond	Downstream Area
Structure	

Legend
Dangerous Waters Identification

- Danger Area
- Warning Area

Data Sources
Land Information Ontario 2020
Created In: ArcMap 10.7

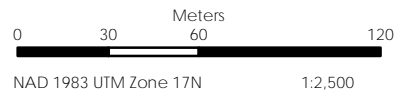


Figure 3 - Component Areas

Drawn By:	DG
Checked By:	DG
Map Date:	12/22/20
Project Number:	20-5426
Map File Number	201221-5426



D.M. Wills Associates Limited
150 Jameson Drive
Peterborough, Ontario
K9J 0B9

P. 705.742.2297
F. 705.748.9944
E. wills@dmwills.com
Copyright © D.M.Wills 2020

5.2 Public Activities and Potential Hazards

Table 1 lists the known and expected public activities and the potential hazards at the Valens Lake Dam.

Table 1 – Public Activities and Potential Hazards

Activity Descriptions	Potential Hazards
Upstream Area	
From Water / Ice	
<ul style="list-style-type: none"> • Fishing from Boat • Boating (Under Power) • Windsurfing • Canoeing / Kayaking / Rowing • Swimming • Swimming/Diving 	<ul style="list-style-type: none"> • Floating Debris
<ul style="list-style-type: none"> • Skating • Ice Fishing 	<ul style="list-style-type: none"> • Steep or Slippery Banks • Thin Ice
From Shore/Structure	
<ul style="list-style-type: none"> • Fishing from Shore • Walking • Picnicking • Hiking • Biking • Swimming / Diving 	<ul style="list-style-type: none"> • Steep or Slippery Banks
<ul style="list-style-type: none"> • Skiing • Snowshoeing 	<ul style="list-style-type: none"> • Steep or Slippery Banks • Thin Ice
Headpond	
From Water / Ice	
<ul style="list-style-type: none"> • Fishing from Boat • Canoeing / Kayaking / Rowing • Swimming 	<ul style="list-style-type: none"> • Strong Currents or Undertows • Presence of Spillway with Stoplogs • Presence of Discharge Valve / Pipe • Submerged Underwater Structures • Steep or Slippery Banks
<ul style="list-style-type: none"> • Skating • Ice Fishing 	<ul style="list-style-type: none"> • Strong Currents or Undertows • Presence of Spillway with Stoplogs • Presence of Discharge Valve / Pipe • Submerged Underwater Structures

Activity Descriptions	Potential Hazards
	<ul style="list-style-type: none"> Steep or Slippery Banks Thin Ice
From Shore/Structure	
<ul style="list-style-type: none"> Fishing from Shore Walking Climbing Hiking Biking 	<ul style="list-style-type: none"> Steep or Slippery Banks
Structure	
From Shore/Structure	
<ul style="list-style-type: none"> Fishing from Shore Walking Climbing Hiking 	<ul style="list-style-type: none"> Presence of Spillway with Stoplogs Steep or Slippery Banks Falling from Height > 3 m
<ul style="list-style-type: none"> Skiing 	<ul style="list-style-type: none"> Steep or Slippery Banks
<ul style="list-style-type: none"> Driving 	<ul style="list-style-type: none"> Steep or Slippery Banks
Tailrace	
From Shore/Structure	
<ul style="list-style-type: none"> Fishing from Shore Walking 	<ul style="list-style-type: none"> Rapidly Increasing Water Levels Rapidly Increasing Water Flows Strong Currents or Undertows Steep or Slippery Banks
Downstream Area	
From Shore/Structure	
<ul style="list-style-type: none"> Fishing from Shore Walking 	<ul style="list-style-type: none"> Steep or Slippery Banks

5.3 Risk Levels

The Public Safety Risk Assessment for the Valens Lake Dam identified that thirty-seven (37) risks exist. These consist of eleven (11) High risks, twenty-two (22) Medium risks and four (4) Low risks. However, these can be changed to zero (0) High risks, twenty-five (25)

Medium risks and twelve (12) Low risks if the reduction measures that have been recommended in the Final Public Safety Risk Assessment Report (Wills, 2021) are implemented.

6.0 Existing Control Measures and Opportunities for Improvement

6.1 Overview of Public Safety Control Measures Purpose

Safety control measures at dams are initiatives designed to protect the public by the installation of physical restraints and by raising awareness of hazards and risks associated with the facility.

Where the risks are high, the consequences severe, a site may be designated a Danger Zone in which unauthorized access is prohibited, and appropriate control measures are implemented. Danger zone risks are generally restricted through the use of restraints and DANGER signs. A restraint is typically defined as a fence, gate, or boom.

Where the risks to life and limb are intermittent or less extreme, a site may be deemed a Warning Zone in which the public are alerted to the specific nature of the risk and warned accordingly. Warning zone risks are generally posted through on-site signage and public education. Public education is typically through media advertising, pamphlets, the corporate website and employee awareness.

Selection of the appropriate control measure depends upon the nature and degree of risk each safety hazard represents to the public. The practicality and effectiveness of implementation and the site-specific conditions being addressed will influence the choice of control measure used.

6.2 Existing Control Measures

6.2.1 Upstream Area

There are a number of public safety measures in place that have the potential to mitigate public safety hazards within the Upstream Area component area, including:

- Public Safety Signs – There is an upstream facing public safety sign installed on the inlet structure (Photo 9). The sign would be difficult to see from the majority of the component area; however, it would be visible once approaching the dam. There are also ice safety signs (Photo 10) installed during the winter months when the ice is considered to be unsafe. Note that the sign in Photo 10 is shown installed at the Christie Lake Dam, however the signs used at the Valens Lake Dam are the same.
- Designated Swimming Area – There is a designated swimming area located within the Conservation Area (Photos 11 and 12). This encourages swimming in a relatively safe area and away from the dam.

- Operational Controls (Procedures) – The HCA has instituted an ice safety program/procedure for Valens Lake in order to allow on-ice activities to be undertaken safely. The minimum ice thickness is 6 inches. The ice thickness is measured once per week, and following rainfall or high temperature events, at five (5) monitoring stations across the reservoir. If the ice is less than 6 inches thick, or the shoreline doesn't have ice, then the ice is closed for public use. When the ice is closed for public use, danger signs are posted at the main ice access points, a notice is posted at the front gate of the conservation area, there are postings on the HCA website and social media and the voicemail message at the conservation area is changed to indicate that the ice is currently unsafe.



Photo 9 – Upstream Facing Sign



Photo 10 – Ice Safety Sign
(Typical from the Christie Lake Dam)

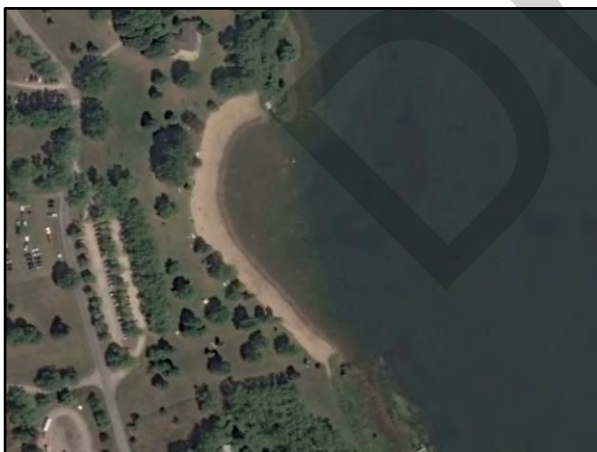


Photo 11 – Aerial View of Designated
Swimming Area



Photo 12 – Ground Level View of
Designated Swimming Area

6.2.2 Headpond

There are a number of public safety measures in place that have the potential to mitigate public safety hazards within the Headpond Area component area, including:

- Public Safety Signs – There is an upstream facing public safety sign installed on the inlet structure (Photo 9).

- Security Patrols – Staff from the Valens Lake Conservation Area visit the site daily. It is understood that these visits are being undertaken at different times each day. This is a good practice to ensure that time-specific public activities are identified.
- Operational Controls (Procedures) – In Section 11 (Public Safety), the OMSS Manual states that the HCA Manager of Water Resources Engineering shall ensure that appropriate safety procedures are implemented to warn the public of potential hazards and/or restrict public access and that the dam operator must ensure access for unauthorized personnel during operations is prohibited; however, consideration for public safety is not included within Section 6 (Operational Procedures). It is understood from staff on site that changes in flows are undertaken gradually, however, this is not expressly written in the OMSS Manual.
- Designated Swimming Area – There is a designated swimming area located within the Conservation Area (Photos 11 and 12). This encourages swimming in a relatively safe area and away from the dam.

The location of the existing public safety measures are shown in Figure 4 and the sign index is included in Appendix B.

6.2.3 Structure

There are a number of public safety measures in place that have the potential to mitigate public safety hazards within the Structure component area, including:

- Public Safety Signs – There is an upstream facing public safety sign installed on the inlet structure (Photo 9). There are also public safety and information signs located on both sides of the inlet structure (Photos 13 and 14) and on the outlet structure railing, facing upstream (Photos 15 and 16).
- Fencing/Railings – There is a railing around the top of the outlet structure headwall and wingwalls (Photo 17). The railing does not meet the requirements of the Ontario Building Code.
- Barricades – There is a concrete barricade around the inlet structure (Photo 18). This barricade generally appears to be adequate for its intended purpose.
- Security Patrols – Staff from the Valens Lake Conservation Area visit the site daily. It is understood that these visits are being undertaken at different times each day. This is a good practice to ensure that time-specific public activities are identified.

The location of the existing public safety measures are shown in Figure 4 and the sign index is included in Appendix B.



Photo 13 – Typical Inlet Structure Sign



Photo 14 – Typical Inlet Structure Sign



Photo 15 – Outlet Structure Sign

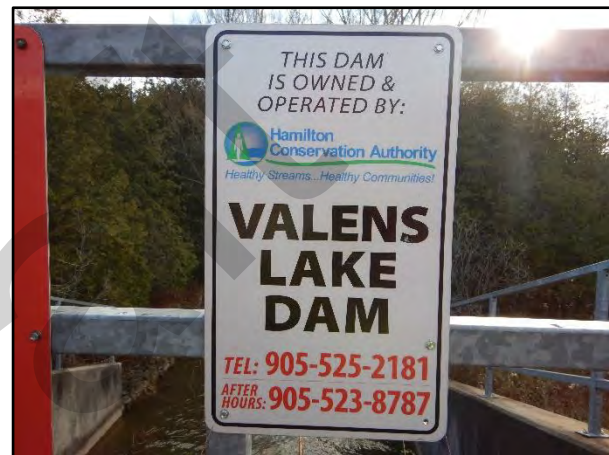


Photo 16 – Outlet Structure Sign



Photo 17 – Outlet Structure Railing



Photo 18 – Inlet Structure Barricade

6.2.4 Tailrace

There are a number of public safety measures in place that have the potential to mitigate public safety hazards within the Tailrace component area, including:

- Security Patrols – Staff from the Valens Lake Conservation Area visit the site daily. It is understood that these visits are being undertaken at different times each day. This is a good practice to ensure that time-specific public activities are identified.
- Operational Controls (Procedures) – In Section 11 (Public Safety), the OMSS Manual states that the HCA Manager of Water Resources Engineering shall ensure that appropriate safety procedures are implemented to warn the public of potential hazards and/or restrict public access and that the dam operator must ensure access for unauthorized personnel during operations is prohibited; however, consideration for public safety is not included within Section 6 (Operational Procedures). It is understood from staff on site that changes in flows are undertaken gradually, however, this is not expressly written in the OMSS Manual.

The location of the existing public safety measures are shown in Figure 4 and the sign index is included in Appendix B.

6.2.5 Downstream Area

There are no existing public safety measures installed within this component area.



Legend

- Railings
- Information Sign
- Public Safety Sign
- Local

Data Sources
 Land Information Ontario 2020
 Created In: ArcMap 10.7

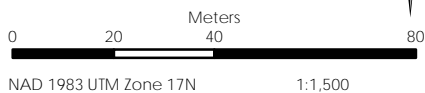


Figure 4 - Existing Public Safety Measures

Drawn By:	DG
Checked By:	DG
Map Date:	12/22/20
Project Number:	20-5426
Map File Number:	201221-5426



D.M. Wills Associates Limited
 150 Jameson Drive
 Peterborough, Ontario
 K9J 0B9
 P. 705.742.2297
 F. 705.748.9944
 E. wills@dmwills.com
 Copyright © D.M. Wills 2020

6.3 Opportunities for Improvement

A number of opportunities for improvement are detailed within the Final Public Safety Risk Assessment Report (Wills, 2021). The following is a summary of those recommendations:

Signage

- During all seasons where ice may be present in the Headpond, place four (4) small signs (DANGER, Thin Ice, Keep Off), two (2), evenly spaced on both sides of the Headpond.

The on-ice activities in the Headpond should be monitored following the implementation of the noted public safety signs. If it is identified that members of the public are using the Headpond area for ice fishing and skating, the HCA should implement further public safety measures, as required, using a staged approach.

- Place two (2), equally spaced, small signs (DANGER, Keep Out, Access Beyond This Point May Result In Drowning) on each of the upstream left and right sides of the dam along the shoreline of the Headpond Component Area.
- Place small public safety signs (DANGER, Access Beyond This Point May Result In Drowning) on the approaches from the left and right sides of the dam.
- Replace the No Trespassing sign near the private dwelling.
- Place a large sign (DANGER, Dam Outflow – Keep Out, Access Beyond This Point May Result in Drowning) on the top of the outlet structure, facing downstream. The sign should include appropriate pictographs.

Public Education (Local Initiatives)

- Warn members of the public of the hazards associated with the dam and its appurtenant structures as they enter the Valens Lake Conservation Area.

This warning could be an information sign (white background with black lettering) posted at the front gate, a verbal warning from Conservation Area staff or a written pamphlet handed out as people enter.

Fencing/Railings/Barricades

- Install gates on the left and right approaches to the dam to prevent unauthorized vehicular access.
- Modify the railings on the outlet structure so that they meet Ontario Building Code requirements.

Security Patrols

- Continue the current practice of undertaking security patrols. Ensure that the security patrols are undertaken on a random basis (i.e. not the same time each day) in order to identify activities that may be undertaken at specific times.
- Document the all public activities (both allowed and prohibited) and public safety incidents using the CDA Public Safety Incident Report form included in Appendix A and develop a spreadsheet to track the public safety activities for reference as part of future PSRAs.

Operational Controls (Procedures)

- Update the OMSS Manual, as follows:
 - Add to all appropriate procedures, the requirement to check the Headpond, Structure and Tailrace component areas for members of the public prior to undertaking any operations.
 - Include procedures for how to deal with members of the public in the event of their presence when the dam needs to be operated.
 - Add to all appropriate procedures, the requirement to increase flows gradually (i.e. using a stepped approach).
 - Update the Section 9 (Records) and/or Section 10 (Public Safety) to include the requirement for HCA staff to record and report public safety activities and incidents. The public safety activities/incidents can be documented using a Microsoft Excel spreadsheet. The CDA Public Safety Incident Report form should be used to record and document all incidents.

It is noted that a number of these recommendations have already been implemented or will be implemented in the near future, including:

- Installation of four (4) small signs (DANGER, Unsafe Ice, Keep Off), two (2), along the shore on each side of the Headpond component area. To be present in winter only and mounted to the same posts as the signs described below.
- Installation of four (4) small signs (DANGER, Keep Out, Access Beyond This Point May Result In Drowning), two (2), along the shore on each side of the Headpond component area.
- Installation of small public safety signs (DANGER, Access Beyond This Point May Result In Drowning) on the approaches from the left and right sides of the dam.
- Replacing the No Trespassing sign near the private dwelling.
- Installation of a large sign (DANGER, Dam Outflow – Keep Out, Access Beyond This Point May Result in Drowning), including appropriate pictographs, on the top of the outlet structure, facing downstream.
- Installation of gates on the left and right approaches to the dam to prevent unauthorized vehicular access.

- Modifying the railings on the outlet structure so that they meet Ontario Building Code requirements.

These additional public safety measures will be identified and considered at the next update/review of the PSRA and PSP.

7.0 Inspection and Maintenance Program

Although observations by staff or others can provide input at any time during the year, annual inspections of the public safety measures at the Valens Lake Dam shall be made and documented on a schedule established by the Director, Watershed Management Practices. It is good practice, when weather and access permit, to inspect the facilities early in the year. In doing so, it will provide sufficient time to complete any repairs or public safety enhancements prior to the summer season. The inspection and maintenance for the public safety measures should include the items described in Table 2, as applicable.

Table 2 – Inspection and Maintenance Requirements

Item	Inspect For	Required Action or Maintenance
Upstream and Downstream Areas	<ul style="list-style-type: none"> • Public presence. 	Notify the public of the hazards created by the dam and its operation.
Signage	<ul style="list-style-type: none"> • All signs are present and accounted for. • Securely mounted. • Clear and understandable. • Visible (limiting factors could include vegetation, size of lettering, snow cover, etc.). • Condition (vandalized, damaged, etc.). 	Replace damaged or missing signs, secure loose signs, remove debris and graffiti, clear vegetation in front of signs.
Fences and Gates	<ul style="list-style-type: none"> • Upright and secure. • No holes or missing sections. • No holes under fence. • No paths established around fence. • No vegetation overgrowing fence. 	Repair or replace damaged fencing or gates.

Item	Inspect For	Required Action or Maintenance
Railings	<ul style="list-style-type: none"> • Structural degradation. • Signs of corrosion. • Loose anchor bolts. • Vandalism. 	Repair and paint.
Safety Boom and Buoys	<ul style="list-style-type: none"> • Cables and anchors secure. • Boom forms a continuous barrier. • Debris accumulation. • Damaged floatation units. 	Remove debris, provide temporary repair solutions and additional signage in the event of boom failure, replace damaged or worn parts and components.
Sirens and Warning Lights	<ul style="list-style-type: none"> • Functioning as intended. • Can be seen / heard from the appropriate distances. 	Repair or replace parts that are not functioning properly, tune volume settings.
Security System and Cameras	<ul style="list-style-type: none"> • Function of security system and cameras. • Cameras cover key areas of the dam site. 	Repair system and replace parts, change the camera angles to ensure proper site coverage.

The annual inspections of the public safety measures shall be documented in order to help establish due diligence. Consistent documentation of the annual inspections could help to identify chronic maintenance issues that affect public safety and could indicate where more attention to some aspects of the PSMP is required. The documentation of the inspections should include the:

- Date of the inspection and name of the person performing it.
- Public safety measures inspected and their current condition.
- Corrective actions necessary and confirmation of any corrective actions taken.
- Adherence of each public safety measure to the current codes and best practices.

Regardless of the initiating factor, the prompt and effective remedy of any deficiency in public safety controls is regarded as a priority; therefore, during inspections, the individual discovering an unsafe condition or an unreliable control device will, if possible, immediately remedy the deficiency. If a safety control device fails, the Inspector will complete and file a deficiency report. If the Inspector cannot remedy the deficiency at the time of inspection, it is the responsibility of the Inspector to:

1. Implement interim safety measures and notify the Director, Watershed Management Services so that full repair can be properly undertaken.

2. Complete the Safety Control Deficiency and Remediation Report (included in Appendix A) and forward it to the Director, Watershed Management Services who will file the report to document all remediation measures.
3. Record any breakage, loss, or failure of a safety control due to vandalism, or other causes, including fallen trees, erosion, high water levels, motor vehicle incidents, acts of trespass into Danger zones, etc.
4. If a safety control fails, mark up the appropriate map to show the specific location of the item to be addressed and describe in the comment section of the Safety Control Deficiency and Remediation Report what the issue is.

Repairs that pose a health and safety risk to the inspector shall not be undertaken as part of the inspection and maintenance program. It is the responsibility of the inspector to determine if the repairs required exist outside their expertise and scope of work. All maintenance items shall be reported to the Director, Watershed Management Services and appropriate actions shall be taken to rectify the deficiencies.

8.0 Public Education Plan

The HCA should implement initiatives that promote public safety and awareness at the site. The initiatives should:

- Inform the public about the risks and hazards related to the dam.
- Communicate roles and responsibilities of the public with respect to following signage and respecting the limits placed by physical control measures.
- Either notify the public or raise their awareness in regard to hazards identified at the site, for example:
 - Safety focused newsletters or pamphlets.
 - Information signs at the entrance of Valens Lake Conservation Area.
 - Verbal information/warning from Conservation Area staff.
 - Targeted social media advertising.
 - Information made available on the HCA's website and social media channels.
 - Coordination and communication with local authorities such as the NDMNRF and OPP, local media and other stakeholders, as appropriate.
- How the public can report any concerns about public safety.

Examples of Public Notifications are shown in Appendix C for the HCA's consideration. These types of notifications could be placed in the newspaper, on the radio and on social media prior to spring/summer. Another Public Notification may be used prior to the winter recreation season to include the hazards of thin ice on the reservoir.

9.0 Incident Reporting

The HCA shall document any public safety incidents involving members of the public. An incident is defined as the potential or actual interaction between a member of the public and a hazard associated with the dam or its operation. This documentation should be used to inform the review and update of the Public Safety Risk Assessment and this PSP. Each incident report should contain, at a minimum, the following information:

- Date and approximate time of incident.
- Location of incident.
- Type of incident.
- Activities and sequence of events that led to the incident.
- Description of any response actions taken.
- Description of any resulting injury.

The Canadian Dam Association Public Safety Incident Report form, included in Appendix A, should be used to document any public safety incidents. All incidents should be reported to the Director, Watershed Management Services. Serious incidents should be reported immediately. Other incidents should be reported on a monthly basis.

10.0 Record Management

This document, the Valens Lake Dam Public Safety Plan, is meant to be a living document and needs to be updated as changes occur at the site. Examples of situations where an update to the Public Safety Risk Assessment and Public Safety Plan may be required include:

- Changes in the degree of public interaction.
- Changes in the potential consequences for a specific public interaction.
- New construction at the site which creates a change in operation.
- Identification of new public interactions.
- Changes in operating procedures.

As a minimum standard, the HCA should maintain and keep the following documentation up-to-date:

- Public Safety Plan (this document).
- Public Safety Risk Assessment.
- Public safety incident reports.
- Maintenance and inspection reports.

It is recommended that the HCA review the effectiveness of the PSP on an annual basis, whenever a new issue is observed or whenever a change at the site (as described above) occurs. The HCA should have the PSP independently reviewed every five (5) years.

The HCA should retain all records and documents for a minimum of two (2) PSRA/PSP review cycles (i.e. 10 years).

Draft

Draft

Appendix A

Forms and Reports



Public Safety Incident Report

1.0 Incident Identification	1.1 Site or Dam Name:	1.2 Incident Date (mm/dd/yy):	1.2 Incident Time: <input type="checkbox"/> AM <input type="checkbox"/> PM	
	1.4 River Name:			
	1.5 Location of Incident:			
	<input type="checkbox"/> Upstream (specific location) <input type="checkbox"/> Penstock <input type="checkbox"/> Authorized public access area <input type="checkbox"/> Headpond <input type="checkbox"/> Spillway <input type="checkbox"/> Boat Ramp(s) <input type="checkbox"/> Dam (e.g. Crest, Roof, Deck) <input type="checkbox"/> Intakes <input type="checkbox"/> Tailrace (designated dangerous area) <input type="checkbox"/> Roadways <input type="checkbox"/> Downstream (specific location) <input type="checkbox"/> Other:			
	1.6 Incident Type:			
	<input type="checkbox"/> Fatality (not a suicide or homicide) <input type="checkbox"/> Trespassing or otherwise entering into a dangerous area <input type="checkbox"/> Injury <input type="checkbox"/> Failure of a physical control measure <input type="checkbox"/> Stranding/rescue <input type="checkbox"/> Failure to follow operating procedures <input type="checkbox"/> Other:			
	1.7 Names of Individuals Involved (if known):		1.8 Names of Eyewitnesses:	
	1.9 Name of First Aid Responder:			
	1.10 Name of Hospital/Clinic:			
	1.11 Name of Responding Police Officer:		1.12 Police Report Number (if applicable):	
2.0 Description of Incident	2.1 Incident Description:			
	2.2 Describe the sequence of events leading to the incident and any injuries that resulted: (Include observations by staff at site, resultant discussion with member(s) of the public, if any etc.)			

Public Safety Incident Report

3.0 Activities	3.1 What was the Persons(s) doing at the time of the injury/incident? From Water / Ice: <ul style="list-style-type: none"> <li style="width: 25%;"><input type="checkbox"/> Fishing from Boat <li style="width: 25%;"><input type="checkbox"/> Boating (under power) <li style="width: 25%;"><input type="checkbox"/> Sailing <li style="width: 25%;"><input type="checkbox"/> Windsurfing <li style="width: 25%;"><input type="checkbox"/> Canoeing/Kayaking/Rowing <li style="width: 25%;"><input type="checkbox"/> Waterskiing <li style="width: 25%;"><input type="checkbox"/> Swimming <li style="width: 25%;"><input type="checkbox"/> Jet Ski <li style="width: 25%;"><input type="checkbox"/> Scuba Diving <li style="width: 25%;"><input type="checkbox"/> Swimming/Diving <li style="width: 25%;"><input type="checkbox"/> Skating <li style="width: 25%;"><input type="checkbox"/> Ice Fishing <li style="width: 25%;"><input type="checkbox"/> Snowmobiling <li style="width: 25%;"><input type="checkbox"/> Other: <li style="width: 25%;"><input type="checkbox"/> Unknown From Shore / Structure: <ul style="list-style-type: none"> <li style="width: 25%;"><input type="checkbox"/> Fishing from Shore <li style="width: 25%;"><input type="checkbox"/> Walking <li style="width: 25%;"><input type="checkbox"/> Climbing <li style="width: 25%;"><input type="checkbox"/> Picnicking <li style="width: 25%;"><input type="checkbox"/> ATV / Dirt Biking <li style="width: 25%;"><input type="checkbox"/> Hiking <li style="width: 25%;"><input type="checkbox"/> Skiing <li style="width: 25%;"><input type="checkbox"/> Snowshoeing <li style="width: 25%;"><input type="checkbox"/> Driving <li style="width: 25%;"><input type="checkbox"/> Biking <li style="width: 25%;"><input type="checkbox"/> Scuba Diving <li style="width: 25%;"><input type="checkbox"/> Swimming/Diving <li style="width: 25%;"><input type="checkbox"/> Accessing electrical equipment <li style="width: 25%;"><input type="checkbox"/> Accessing mechanical equipment <li style="width: 25%;"><input type="checkbox"/> Other: <li style="width: 25%;"><input type="checkbox"/> Unknown <li style="width: 25%;"><input type="checkbox"/> Trespassing 		
4.0 Control Measures	4.1 Select Physical Control Measures in place at time of the incident: <ul style="list-style-type: none"> <li style="width: 25%;"><input type="checkbox"/> Signage <li style="width: 25%;"><input type="checkbox"/> Public Education (local) <li style="width: 25%;"><input type="checkbox"/> N/A <li style="width: 25%;"><input type="checkbox"/> Safety Booms <li style="width: 25%;"><input type="checkbox"/> Video Surveillance <li style="width: 25%;"><input type="checkbox"/> Safety Buoys <li style="width: 25%;"><input type="checkbox"/> Fencing <li style="width: 25%;"><input type="checkbox"/> Vehicle Barricades <li style="width: 25%;"><input type="checkbox"/> Visual Danger Signal Device <li style="width: 25%;"><input type="checkbox"/> Audible Danger Signaling Devices <li style="width: 25%;"><input type="checkbox"/> Operational Control Procedure <li style="width: 25%;"><input type="checkbox"/> Security Patrols <li style="width: 25%;"><input type="checkbox"/> Other: 		
5.0 Environmental	5.1 Select the Physical / Environmental Factor(s) relevant to the incident <ul style="list-style-type: none"> <li style="width: 25%;"><input type="checkbox"/> N/A <li style="width: 25%;">Physical: <ul style="list-style-type: none"> <input type="checkbox"/> Slope Instability <input type="checkbox"/> Steep Slopes <input type="checkbox"/> Uneven Surfaces <input type="checkbox"/> Slippery Surfaces <input type="checkbox"/> Strong Currents/Undertow <input type="checkbox"/> Failure of Vehicle or Vessel <li style="width: 25%;"> <ul style="list-style-type: none"> <input type="checkbox"/> Rapid Water Rise <input type="checkbox"/> Sudden Release of Water <input type="checkbox"/> Remote Release of Water <input type="checkbox"/> Ramped Release of Water <input type="checkbox"/> Floating Debris <input type="checkbox"/> Failure of Ice Cover <li style="width: 25%;"> <ul style="list-style-type: none"> <input type="checkbox"/> Inaccessible Location <input type="checkbox"/> Exposed Equipment <input type="checkbox"/> Sharp Objects <input type="checkbox"/> Structural Failure <input type="checkbox"/> Energized Equipment <input type="checkbox"/> Other: <li style="width: 25%;">Environmental: <ul style="list-style-type: none"> <input type="checkbox"/> Cold Environment <input type="checkbox"/> Hot Environment <input type="checkbox"/> Rainy Conditions <input type="checkbox"/> Snow/Ice <li style="width: 25%;"> <ul style="list-style-type: none"> <input type="checkbox"/> Windy Conditions <input type="checkbox"/> Dark, Night Conditions <input type="checkbox"/> Low Lighting <input type="checkbox"/> Low Visibility <li style="width: 25%;"><input type="checkbox"/> Other: 		
6.0 Corrective Measures	6.1 Describe any Immediate Action(s) Taken as a result of the incident. (i.e. Corrective actions, warnings issued, charges laid, control measure repaired or upgraded, procedures written I amended) <div style="text-align: center; font-size: 48px; opacity: 0.2; font-weight: bold; margin-top: 20px;">DRAFT</div>		
7.0 Contact Information	7.1 Contact Person on Site:	7.2 Submitted by:	

Public Safety Measures Inspection Form

Location:	Valens Lake Dam
Inspector:	
Inspection Date:	

ID Code	Location/Component	Deficiency Description/Comment
Booms / Buoys		

Draft

Public Safety Plan Modification Report

Location: Valens Lake Dam

Safety Issue:

Component: Headpond Structure
 Tailrace

Description: _____

Modifications Required:

Boom (b) Fence (f) Sign (s) Other: (specify) _____

Modification Description: _____

Safety Control ID Assigned: _____

Modification Completed:

Notes: _____

PSP Report Revisions Completed:

- N/A Map(s) Revised
- N/A Sign Index Revised
- N/A Public Notifications Revised
- N/A Deficiency and Remediation Report(s) Revised
- N/A Other: _____
- N/A Revised Page(s) digital copy / web pages updated

PSP Report Revisions Distributed:

Completed (Person Responsible for Modification) Date

Approved (Water Resources Manager) Date

Draft

Appendix B






Sign Index



Sign Index – Valens Lake Dam

Updated April 14, 2022

Sign ID	Sign	Size	Location	Photo
100		12" x 20"	Right Side of Inlet Structure	
101		12" x 20"	Right Side of Inlet Structure	
102		35" x 54"	Inlet Structure, Facing Upstream	
103		12" x 20"	Right Side of Inlet Structure	

Sign ID	Sign	Size	Location	Photo
104		12" x 20"	Right Side of Inlet Structure	
105		12" x 20"	Left Side of Dam	
106		47" x 94"	Outlet Structure, Facing Upstream	
107		12" x 20"	Outlet Structure, Facing Upstream	

Sign ID	Sign	Size	Location	Photo
108		18" x 30"	Shoreline on upstream right side of dam	TBC
109		18" x 30"	Shoreline on upstream right side of dam	TBC
110		18" x 30"	Shoreline on upstream right side of dam	TBC
111		18" x 30"	Shoreline on upstream right side of dam	TBC
112		18" x 30"	Approach to embankment dam from left side	TBC

Sign ID	Sign	Size	Location	Photo
113		18" x 30"	Approach to embankment dam from right side	TBC
114		42" x 94"	Outlet Structure Facing Downstream	TBC

Draft

Draft

Appendix C

Sample Notifications

Example Public Notification 1 – Reservoir, Summer

<p>Safety on Reservoirs Valens Lake Dam and Valens Lake</p>
<p>Warning</p> <p>Play it safe when visiting the Valens Lake Dam and Valens Lake.</p> <p>Valens Lake in the vicinity of the Valens Lake Dam can be an enjoyable recreational destination, provided certain safety precautions are observed.</p> <p>Boating, fishing and swimming above or below the dam can be very dangerous. For your own safety and the safety of those with you, obey all warning signs and stay out of all restricted areas.</p> <p>Boaters must comply with all Canadian Coast Guard regulations and practice safe boating at all times.</p> <p>When boating please wear your life jacket (personal floatation device, PFD)</p> <p>Hamilton Conservation Authority</p>

Example Public Notification 2 – Reservoir, Winter

<p>Safety on Reservoirs Valens Lake Dam and Valens Lake</p>
<p>Warning</p> <p>Play it safe when visiting the Valens Lake Dam and Valens Lake this winter.</p> <p>Valens Lake upstream of the Valens Lake Dam can be an enjoyable recreational destination, provided certain safety precautions are observed.</p> <p>Flowing water may cause thin ice in areas immediately upstream of the dam. The ice thickness is monitored by Hamilton Conservation Authority. Ice status conditions are posted onsite and on Hamilton Conservation Authority's website.</p> <p>Engaging in activities on the ice can be dangerous. Please observe and follow posted signs.</p> <p>Hamilton Conservation Authority</p>

Example Public Notification 3 – Safety Around Dams, General

Safety Around Dams

Valens Lake Dam

An important message for visitors

Hamilton Conservation Authority's dam facilities can be interesting places to visit, provided certain precautions are observed.

Water control structures and dams, and the areas nearby can be dangerous to the unwary or the adventurous. Some hazards are readily apparent but others are not. Some hazards such as water flows immediately upstream of a dam may seem calm and safe to be in, but they are not. Instead, water flow immediately upstream of a water control structure is dangerous and contains strong currents and undertows that can easily cause a person who enters the water to drown.

Visitors should stay well clear of dams, water intake and conveyance structures, powerhouses, discharge channels and all electrical, mechanical and monitoring equipment. Areas of water immediately upstream and downstream of dams and generating facilities are hazardous.

Please respect fenced and gated areas and observe all posted signs. Stay on designated trails and be sure to supervise children closely.

For further information about our operations, please visit our website at www.conservationhamilton.ca.

Have a safe and informative visit!

Hamilton Conservation Authority

This page intentionally left blank.



Report

TO: Conservation Advisory Board

FROM: Lisa Burnside, Chief Administrative Officer (CAO)

RECOMMENDED BY: Matthew Hall, Director; Capital Projects & Strategic Services

PREPARED BY: Madolyn Armstrong, Landscape Architect; Capital Projects & Strategic Services

MEETING DATE: April 11, 2024

RE: Saltfleet Study Area Master and Management Plans

STAFF RECOMMENDATION

THAT the Conservation Advisory Board recommends to the Board of Directors:

THAT this report and accompanying Master and Management Plans of March 2024 be received as information for project background and general understanding;

and further

THAT the Saltfleet Conservation Area Master Plan, Dofasco 2000 Trail Management Plan and Winona and Vinemount Conservation Areas Management Plan of 2024 be approved.

and further

THAT the Winona and Vinemount Conservation Areas Management Plan be submitted to the NEC and MNR for final approval.

BACKGROUND & PURPOSE

The HCA Ten Year Master Plan Update Strategy was approved by CAB on February 14, 2019 and by the Board of Directors on March 7, 2019 for properties that HCA owns and manages. As per this strategy document, the scheduled study area for review in

2022 was the Saltfleet Conservation Area Study Area, which includes Saltfleet Conservation Area, Devil's Punchbowl Conservation Area, the Dofasco 2000 Trail and Winona and Vinemount Conservation Areas. This set of plans is intended to provide direction and guidance for the next ten years of operation for these conservation lands.

A report on these master and management plans was provided to CAB in April 2022 when staff were beginning the update process. Following that, a facilitated discussion was held with CAB members in December 2022 that focused on the site concept and trails included in the plan for Saltfleet Conservation Area. Since that time, staff have undertaken a review and commenting period internally and externally, involving staff, Board members, stakeholder agencies and the public to finalize the draft plans that are presented with this report. Work on these plans began in January 2022 and was implemented by HCA staff through a four-stage process. Throughout the process the plans were refined through ongoing consultation with HCA's staff steering committee, stakeholder agencies and public circulation as follows:

- **Phase 1 Background** began in January 2022 and was completed in summer 2022. This phase included engagement with HCA staff in all departments and forming the HCA staff steering committee, collection of background information, assembling mapping information, and presentation of an information report to CAB in April 2022.
- **Phase 2 Inventory** included the collection and assembly of natural areas field surveys and mapping information, ecological reports, trail counter data and public surveys. Two public information booths were operated by staff at Devil's Punchbowl Conservation Area in July and August 2022. Visitor surveys for Saltfleet and Devil's Punchbowl ran from May to September 2022 on the Bang the Table website. 150 surveys were submitted by the public for Saltfleet and 100 for Devil's Punchbowl. Visitors to the information booths and to HCA's online public engagement site were also able to register to receive updates on the project.
- **Phase 3 Concepts and Drafts** were completed in-house by HCA staff through a series of five facilitated workshop sessions covering site concepts and vision planning, finance and attendance, day use and marketing, and capital project priorities and plans. This also included a facilitated discussion with CAB members in December 2022. All information gathered was considered for the draft plan during this phase, along with the information submitted through public surveys. The plan was further refined from stakeholder comments received in Phase 4.
- **Phase 4 Review and Commenting** included reviews of the compiled draft plan by HCA staff and steering committee, outside agencies, stakeholders including First Nations, CAB, Board of Directors, and members of the public. The review and commenting period for the plans took place from February to April 2023, with the exception of ongoing consultation with the NEC, MNRF and First Nations. As of March 2024, remaining consultation with these groups was completed for the Saltfleet, Dofasco 2000 Trail and Winona and Vinemount plans. These three plans

are now at 95% and will be completed upon endorsement by the Conservation Advisory Board and approval by the HCA Board of Directors.

The Devil's Punchbowl Conservation Area Master Plan is currently under review with the NEC and MNRF. The final draft will be brought forward for CAB endorsement when this review process is complete.

STAFF COMMENT

Saltfleet Conservation Area

This is the first master plan that HCA has undertaken for Saltfleet Conservation Area (Saltfleet). Saltfleet is comprised of six properties on top of the Niagara Escarpment in Stoney Creek. HCA acquired the lands following an Environmental Assessment in 2011 with the vision of creating multiple wetlands to address flooding and erosion below the Niagara Escarpment as well as to provide new and restored natural areas in the watershed and opportunities for passive recreation. The wetlands were completed in the fall of 2022 and Saltfleet opened to the public.

Key items that are addressed in this master plan include:

- Natural Areas
 - The purpose and function of the BC-1 wetlands on the main Saltfleet property and anticipated ongoing monitoring and maintenance.
 - The planned addition of a new wetland complex on the Saltfleet property at Green Mountain Road and Fifth Road East.
 - The addition of perimeter fencing and planting buffers where needed to protect the site.
 - The planned conversion of the former agricultural fields to naturalized areas.
- Conservation Area and Day Use Development
 - Recommended improvements to the laneway and parking lot including autogates and signage.
 - Recommended facilities to be added including a washroom building and picnic pavilion at the parking lot.
 - Expansion of the recreational trail system to include the berms around the wetlands and the former agricultural fields. The layout of the trail system that is shown in Appendix 1 of the master plan was the focus of a facilitated workshop with CAB members in December 2022.
 - Addition of wayfinding and interpretive signage throughout the property.

In late 2023, HCA acquired a 95.38-acre parcel of land on Tapleystown Road needed to finalize the Saltfleet Wetland Restoration Program. An amendment to the Saltfleet

Master Plan with details and direction for this new property will be brought forward to the Board in the future.

Dofasco 2000 Trail

The Dofasco 2000 Trail is an 11.5-kilometre multi-use recreational trail located on top of the Niagara Escarpment. The trail runs from Ridge Road at the Devil's Punchbowl, past Saltfleet, across to Eleventh Road East. The trail was built over twenty years ago with the support of the Hamilton Conservation Foundation, Dofasco Inc., the Millennium Bureau of Canada and the City of Hamilton (City), and is operated under a management agreement between HCA and the City. This Management Plan will update and replace the Powerline Road Trail Master Development Plan that was approved by the HCA Board of Directors in 2000.

Key items that are addressed in this management plan include:

- Trail Infrastructure
 - Full inventory and description of the trail from Ridge Road to Eleventh Road East was completed.
 - Recommended trailhead amenities and signage at Devil's Punchbowl and Saltfleet Conservation Areas and implementation of a trail signage improvement program.
 - Recommended improvements to trail surfacing and buffering along the trail where needed.
 - Recommended road crossing improvements, including at Ridge Road in coordination with the City of Hamilton
 - The portion of trail between First Road East and Ridge Road will be rerouted with the addition of the future SC-5 wetland on the Devil's Punchbowl property.
- Environment Management
 - Updated terrestrial and aquatic ecological inventories were conducted for the trail.
 - Recommended ongoing invasive species management and replanting to restore natural regenerating ecosystems within the trail corridor.
 - Recommended ongoing aquatic review of watercourse crossings to maintain infrastructure and safe fish passage.

Additional items that were reviewed during the management plan process:

- The addition of parking near the east of the trail was discussed. It was concluded that there are no HCA owned properties that would be suitable for a parking lot other than the existing lots at Devil's Punchbowl and Saltfleet.

Winona and Vinemount Conservation Areas

Vinemount and Winona Conservation Areas were established in the 1970's from HCA's strategic land acquisition to secure these sensitive Escarpment lands threatened by urban sprawl. The properties are adjacent to each other and run along the face of the Niagara Escarpment with a few areas of tableland above and below. They are connected by the Bruce Trail, which also links them to Devil's Punchbowl to the west. This management plan will update and replace the 1979 Master Development Plans prepared by HCA staff for both areas.

Key items that are addressed in this management plan include:

- The importance of protecting the sensitive features and functions of these Escarpment lands and maintaining low density recreational use.
- Updated terrestrial and aquatic ecological inventories were conducted for all properties.
- Recommended actions to enhance biodiversity and long-term forest resiliency through control of invasive species and restoration plantings.
- Recommended ongoing support of the Bruce Trail through these properties and relationship building with the Bruce Trail Conservancy.

Additional items that were reviewed during the management plan process:

- Staff reviewed the possibility of creating a parking area and trail access point on the largest piece of table land at Ridge Road and McNeilly Road. It was determined that there is no reasonable trail connection that could be made from this area down the Escarpment to the Bruce Trail, so this concept was ultimately not supported by staff.

Summary of Saltfleet Public Survey and Commenting

Public surveys are conducted during the master plan process as part of Phase 2 described above. A public survey for Saltfleet Conservation Area was available through the Bang the Table website from May 27th to September 11th 2022. 150 surveys were completed. Below is a summary of feedback received from visitors and the engaged public. A summary of the survey results is also included in Appendix 4 of the master plan.

- Approximately one third of people surveyed had not yet visited Saltfleet Conservation Area.
- From the choices provided in the survey, the three most popular reasons for visiting Saltfleet would be for hiking trails, for nature appreciation, and because parking is available.
- From the choices provided in the survey, the top five amenities or services that people would be interested in HCA offering at Saltfleet were benches, bird watching areas, washrooms, self-guided tours, and a picnic shelter.

- An open response question asking for any additional comments or suggestions for Saltfleet was included. Some of the most common themes in responses were:
 - Requests for permanent washroom facilities
 - Appreciation for the preservation of natural areas
 - Desire for more walking/hiking trails, preferably paved and accessible
 - Desire for more bicycle trails, some requests for mountain bike and gravel bike trails. Comments requesting that these activities not be permitted were also received.
 - Accessibility for visitors of all ages and abilities
 - Providing features/activities for visitors from all age groups
 - Educational opportunities focused on the natural features of the site
 - On the topic of parking, comments varied and included requests to provide lots of parking spaces, to provide free parking, to offer a reservation system, and to refrain from using a reservation system.

Summary of Phase 4 Review and Commenting

The following is a brief overview of the key items brought forward through internal and external review and commenting in Phase 4 described above that resulted in edits to the final draft plans:

General Edits

- The key areas of focus from HCA's Climate Change Strategy were added into all three documents.
- HCA's Land Acknowledgement, which was approved in June 2023, was added into all three documents.

Saltfleet Conservation Area Master Plan

First Nations

- Section 4.6 Cultural Heritage - Some language and historical context was modified following consultation with local First Nations.

HCA Staff

- Section 9.2 Education and Interpretive Programs – Climate change was added to the list of themes for future interpretive signage.
- Appendix 1 – Maps 3, 5 and 6 were updated to show a new parking lot and laneway layout following further site investigation and detailed design by HCA staff.

Dofasco 2000 Trail Management Plan

HCA Staff

- Section 5.1 Trail Infrastructure – The details of existing trail infrastructure received some minor clarifications through comments received from HCA conservation area staff who manage the trail.

Winona and Vinemount Conservation Areas Management Plan

Bruce Trail

- Section 6.7.1 - Clarification on the role of the Bruce Trail staff and volunteers in maintaining the trail though the area was provided by Bruce Trail staff.

NEC and MNRF

- Section 1.0 Approval Statement - Signatory lines were added for the NEC Director and MNRF Resource Planning and Development Policy Branch Director. This is necessary for this plan because it is within the Niagara Escarpment Plan Area.
- Section 3.2 Property History - A paragraph recognizing Indigenous Peoples in the study area was added to the beginning of this section.
- Section 3.3 Planning and Development Controls – Text was updated to better reflect the planning context of these lands being within the Niagara Escarpment Plan (NEP) Area.
- Section 3.4 Management Plan Zones – Descriptions and permitted uses for the applicable Zones were reformatted into tables.
- Section 6.4 and 7.1.3 – Updated to encourage mention of the NEPOSS and the Escarpment's World Biosphere Reserve status in future signage and interpretive materials.
- Appendix 1 – A map showing the extent of the Niagara Escarpment Plan Area and designations in the study area was added (Map 3).
- Appendix 2 – Capital Development Priorities was updated to include estimated budgets for the development line items.

STRATEGIC PLAN LINKAGE

The initiative refers directly to the HCA Strategic Plan 2019 - 2024:

- **Strategic Priority Area – Organizational Excellence**
 - Initiatives – Identify opportunities to engage the community, adjacent landowners, and Indigenous Peoples.
- **Strategic Priority Area – Natural Heritage Conservation**
 - Initiatives – Identify restoration projects in master plans.

- Initiatives – Identify details of the approved Invasive Species Strategy and natural heritage plans in HCA master plans.
- **Strategic Priority Area – Conservation Area Experience**
 - Initiatives – Update and develop master and management plans, and implement priorities to further enhance conservation areas for current and future generations.
- **Strategic Priority Area – Education and Environmental Awareness**
 - Initiatives – Identify and create input and engagement opportunities for conservation area visitors on site.

AGENCY COMMENTS

These plans include lands within the municipal boundaries of the City of Hamilton and watershed boundary of the Niagara Peninsula Conservation Authority. These agencies were circulated for their comments during the external consultation period. No changes to the draft documents were required following this consultation.

The Winona and Vinemount Conservation Areas are within the Niagara Escarpment Plan Area. The Niagara Escarpment Commission (NEC) and Ontario Ministry of Natural Resources and Forestry (MNR) were consulted at the beginning of the management plan process as well as during the external commenting and review period. The NEC and MNR provided comments on the draft plan, which have been incorporated, and agency staff have given their endorsement for the document to be finalized.

LEGAL/FINANCIAL IMPLICATIONS

Not applicable.

CONCLUSIONS

These plans will support the goals as outlined in HCA's 2019-2024 Strategic Plan as well as the Ten Year Masterplan Update Strategy. This information has been provided as background for review and recommendation that the Saltfleet Conservation Area Master Plan, Dofasco 2000 Trail Management Plan and Winona and Vinemount Conservation Areas Management Plan be endorsed by the Conservation Advisory Board and approved by the HCA Board of Directors as the official policy documents for the management and development of these conservation areas. Following this internal approval, HCA staff will proceed to send the final Winona and Vinemount Management Plan to the NEC for endorsement and MNR for approval.



Saltfleet Conservation Area Master Plan

Draft - March 2024



Prepared by: Hamilton Region Conservation Authority (HCA).

Front Cover Photo Credits: Water's Edge Environmental Solutions Team LTD.

Other Photo Credits: HCA Staff unless otherwise specified.



TABLE OF CONTENTS

1.0	APPROVAL STATEMENT.....	1
2.0	PREFACE	2
3.0	EXECUTIVE SUMMARY.....	4
3.1	Introduction	4
3.2	Goals	6
3.3	Objectives	9
3.4	Site Concept	9
3.5	Policy and By-Law Framework	9
3.6	Master Plan Zones.....	10
3.7	Development Priorities.....	18
4.0	BACKGROUND	20
4.1	Study Area	20
4.2	Property History	22
4.3	Planning and Development Controls	24
4.4	Buildings	28
4.5	Physical Features	30
4.6	Cultural Heritage	32
4.7	Heritage Designation and Historic Buildings	34
4.8	Natural Areas.....	35
5.0	NATURAL AREAS INVENTORY.....	36
5.1	Physiography and Topography	36
5.2	Soil Composition	36
5.3	Hydrology and Surface Drainage	37
5.4	Biophysical Inventory Methodology	40
5.5	Ecological Land Classification	40
5.6	Flora/Botanical Inventory	41
5.7	Fauna Inventory	41
5.8	Waterfowl, Migratory and Bird Breeding Surveys	42
5.9	Ecological Land Classification Results.....	42
5.10	Flora/Botanical Inventory Results	43
5.11	Fauna Inventory Results	43
5.12	Aquatic Inventory	47
5.13	Significant Ecological Features.....	49
5.14	Biophysical Inventory – Analysis.....	50

5.15	Managed Forest.....	58
5.16	Natural Areas Recommendations	58
6.0	OVERALL SITE CONCEPT.....	66
6.1	Natural Areas Development.....	66
6.2	Conservation Area Development	67
6.3	Day Use Activity Areas	67
6.4	Marketing.....	67
7.0	CONSERVATION AREA MANAGEMENT	69
7.1	Land and Water Management	69
7.2	Vegetation Management.....	70
7.3	Fish and Wildlife Management.....	71
7.4	Cultural Heritage Management.....	72
7.5	Conservation Area Operations.....	73
7.6	Education.....	73
7.7	Research	73
7.8	Recreation	74
7.9	Partnerships.....	75
7.10	Paid Staff	75
8.0	FINANCIAL.....	76
8.1	Attendance and Revenue Forecasts.....	76
8.2	Capital Projects.....	77
8.3	Funding Sources.....	78
8.4	Business Model	78
9.0	PROGRAMMING	80
9.1	Special Events Programming.....	80
9.2	Education and Interpretive Programs	80
10.0	SUMMARY.....	81
11.0	APPENDIX CONTENTS	82
	Appendix 1 – Mapping.....	83
	Appendix 2 – Capital Development Priorities	91
	Appendix 3 – Operating Revenue and Expenses.....	93
	Appendix 4 – Public Survey Results.....	95
	Appendix 5 – Managed Forest Plan	97
	Appendix 6 – Natural Inventory – Species List & References	108
	Appendix 7 – References	165

LIST OF FIGURES

Figure 1.	Context Map.....	5
Figure 2.	Study Area	21
Figure 3.	Subwatershed Map.....	23
Figure 4.	City of Hamilton Zoning Map.....	26
Figure 5.	Policy Areas.....	29
Figure 6.	Structures and Karst Features.....	31
Figure 7.	Conceptual Geological Section.....	37
Figure 8.	Soil Composition.....	38
Figure 9.	Tourism Region.....	76

LIST OF TABLES

Table 1.	Nature Reserve Zone.....	12
Table 2.	Natural Environment Zone.....	13
Table 3.	Access Zone.....	14
Table 4.	Cultural Heritage Zone.....	15
Table 5.	Development Zone.....	16
Table 6.	Resource Management Zone.....	17
Table 7.	Summary of Ecological Field Studies.....	40
Table 8.	Floristic Quality Index.....	43
Table 9.	Fish Recorded BC-1.....	48
Table 10.	Fish Recorded SC-8.....	48
Table 11.	Fish Recorded Vinemount Swamp.....	49
Table 12.	Fish Records Mainstream Stoney Creek.....	49
Table 13.	Significant Flora.....	51
Table 14.	Federal & Provincial Species at Risk.....	52
Table 15.	Locally Rare and Uncommon Species.....	53
Table 16.	Species of Conservation Concern.....	57

1.0 APPROVAL STATEMENT

We are pleased to approve the Saltfleet Conservation Area Master Plan as the official policy document for the Hamilton Region Conservation Authority (HCA).

This Master Plan supports HCA's current Strategic Plan and reflects our Vision of a healthy watershed for everyone and Mission to lead in the conservation of our watershed and connect people to nature.

Moving forward over the next ten years this plan will help guide the development and operation of this new conservation area in support of these goals.

Lisa Burnside
Chief Administrative Officer
Hamilton Conservation Authority

Date

Brad Clark
Chair, Board of Directors
Hamilton Conservation Authority

Date

2.0 PREFACE

The Saltfleet Conservation Area Master Plan is the guiding policy document for the development and management of this new conservation area which is owned and administered by the Hamilton Region Conservation Authority (HCA). The recommendations in this Master Plan are intended to help provide direction and guidance for sustainable development, management, and operation of the Saltfleet Conservation Area (SCA) over the next ten years.

This Master Plan was developed in four phases by HCA staff, utilizing in-house staffing expertise and resources, with a public consultation process to receive input from stakeholders and the public as follows:

Phase 1 Background

Background review was initiated January 2022 with the HCA executive team review of the work plan, engagement of staff, collection of mapping information, and gathering information through review of HCA's office files and staff meetings. An information report was presented to the HCA Conservation Advisory Board in April 2022, and Phase 1 was completed by October 2022.

Phase 2 Inventory

Inventory includes the collection and assembly of natural areas field surveys and mapping information, ecological reports, trail counter data, and engagement to gather public comments. HCA staff initiated their inventory review in 2020 and began field work in the spring of 2021. A public engagement site was launched on HCA's website in May 2022 to receive comments and deliver visitor surveys. HCA's social media was used to promote the engagement site. Flyers were posted in the study area giving visitors QR codes and weblinks to the surveys. The survey period ran from May 18th to September 9th, 2022, with 150 surveys submitted. While the site was closed to the public for the wetland construction project, two public information booths were held at the Devil's Punchbowl on July 16 and August 6, 2022. Staff shared information on the plan, responded to questions, and signed up visitors interested in receiving the draft plan for review and comment. Visitors to the public engagement site during this phase were also able to register online to receive and comment on the draft Master Plan in Phase 4.

Phase 3 Concepts

Concepts in this plan were completed in-house by HCA staff and refined with the information in the public surveys and input from stakeholders. A working team of staff were assembled with the necessary expertise and experience to help inform this plan. Five facilitated workshop sessions were held with the staff working team covering: a guided site tour of the wetland construction sites and natural areas; site concept and vision planning; financial sustainability; day use and marketing; and capital project priorities and plans. One facilitated trail and site concept planning meeting was held with HCA's Conservation Advisory Board. All information gathered in this phase was presented internally to HCA staff for review and comment, and then compiled in the draft plans circulated in Phase 4.

Phase 4 Summary

Finalizing the draft Master Plan includes reviews of the compiled draft plan by staff, stakeholders,

board advisory members, and circulation to the public who registered in Phase 2. The final draft document includes all stakeholder and public comments. After receiving final comments, the plan is to be presented to HCA's Conservation Advisory Board and then to the HCA Board of Directors for their endorsement and approval.



3.0 EXECUTIVE SUMMARY

3.1 Introduction

Saltfleet Conservation Area (SCA) is located at 444 First Road East, Stoney Creek, City of Hamilton. There are also five other properties associated with SCA identified in this Master Plan. The six properties total 147 ha (363 acres) in size, in the upper Stoney Creek and Battlefield Creek watersheds, as well as a small portion outside of HCA's watershed. The acquisition of these lands in the study area was made possible through donations from the City of Hamilton and Heritage Green Community Trust. SCA is HCA's newest conservation area in the watershed. See Figure 1. Context Map for more information.

HCA started acquiring land for SCA in 2015 and the development plans for the constructed wetlands were prepared between 2018 to 2020. The conservation area initially opened to the public October 2nd, 2021, and then temporarily closed for the wetland development. The conservation area re-opened to the public on September 23rd, 2022.

The main SCA property containing the BC-1 constructed wetland, parking, and visitor entrance from First Road East is the focus of this Master Plan

This is HCA's first Master Plan for Saltfleet Conservation Area.



Photo credit: Water's Edge Environmental Solutions Team LTD.

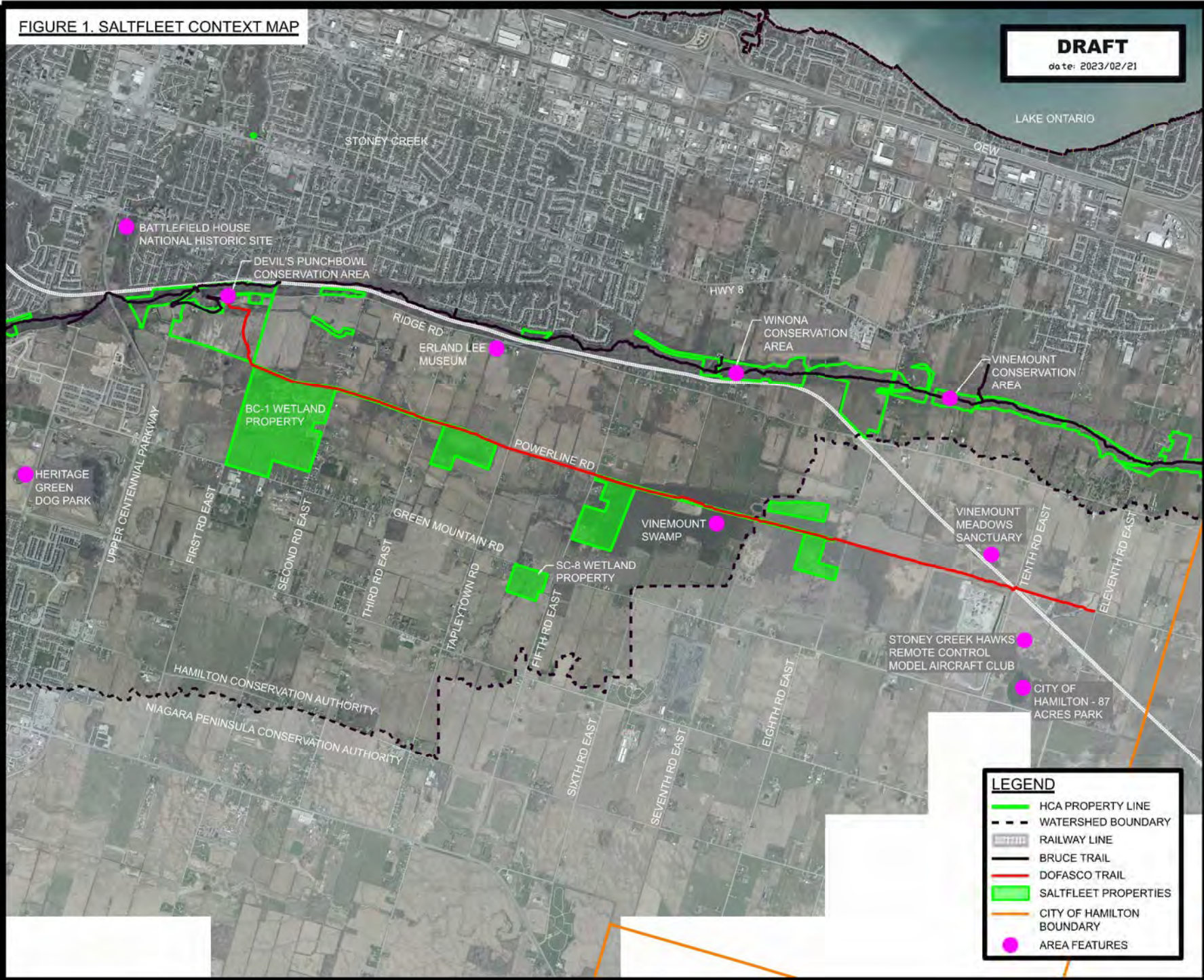
FIGURE 1. SALT FLEET CONTEXT MAP

DRAFT

date: 2023/02/21

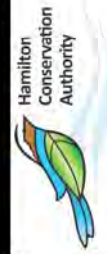


DATE: 2023/02/21



LEGEND

- HCA PROPERTY LINE
- WATERSHED BOUNDARY
- RAILWAY LINE
- BRUCE TRAIL
- DOFASCO TRAIL
- SALT FLEET PROPERTIES
- CITY OF HAMILTON BOUNDARY
- AREA FEATURES



A Healthy Watershed for Everyone

3.2 Goals

This Master Plan outlines the long-term goals for conservation and land management at SCA and is intended to be a living document that will be updated completely in ten years' time.

Land Acknowledgement

The HCA joins in stewardship of lands and waters with Indigenous Peoples who have cared for them since time before memory. We acknowledge that the land on which we gather, and the HCA watershed, is part of the Treaty Lands and Territory of the Mississaugas of the Credit First Nation and traditional territory of the Haudenosaunee.

As an organization, we are committed to learning about the shared history and experiences of Indigenous Peoples in Canada and creating relationships based on respect, trust and friendship. In our shared gratitude for every aspect of the natural world, may we create a lasting legacy now and for future generations.

HCA Strategic Plan

This plan supports the following goals as outlined in HCA's current strategic plan:

Vision

- A healthy watershed for everyone.

Mission

- To lead in the conservation of our watershed and connect people to nature.

Commitment and Corporate Values

- Provide excellent customer service and a solution-oriented approach.
- Be accountable, transparent, and responsible in the use of resources.
- Embrace new technologies to help develop new ways of doing business and foster innovation.
- Promote teamwork internally and externally to achieve common goals, support existing relationships and build new partnerships.
- Maintain trust, act with integrity, and treat others with respect.
- Value knowledge to continually learn and improve, in an effort to achieve best solutions.

Organizational Excellence

- Ensure corporate and financial viability and the HCA's relevance in the community.
- Identify opportunities to engage the community, adjacent landowners, and Indigenous Peoples.

Water Management

- Protect the watershed for people, property, flora and fauna, and natural resources through flood and erosion control, water quality programs, low flow augmentation and adaptation strategies to adapt to changing climatic conditions.

Natural Heritage Conservation

- Conservation, restoration and enhancement of watershed natural areas and ecology.
- Continue on-going ecological restoration projects and monitoring programs.
- Identify invasive species strategies and natural heritage plans in the Master plan.

Conservation Area Experience

- Provide high quality, diverse conservation areas that promote outdoor recreation, health, and well-being and strengthen public awareness of the importance of being in or near our conservation areas.
- Update and develop master and management plans and implement priorities to further enhance conservation areas for current and future generations.

Education and Environmental Awareness

Provide outdoor learning experiences for students, teachers, and the community, increasing knowledge and awareness of the value of our environment and heritage.



In addition to the above strategic goals, HCA acquired the SCA properties with these three land management goals in mind:

1. To address flooding and erosion downstream within the Stoney Creek urban area.
2. To support biodiversity by creating new natural areas and connective corridors within the watershed.
3. To support community well-being by creating new recreational opportunities and connections to other conservation lands utilizing the Dofasco 2000 Trail.

HCA Climate Change Strategy

The goal of HCA's Climate Change Strategy is to work towards achieving net zero status across HCA's operations through the reduction of greenhouse gases (GHG's), while also working to increase our overall adaptive capacity to changing climatic conditions

Key Areas of Focus

Environment and Natural Heritage

- Water Management
 - Reduce water runoff, contamination, soil erosion, and other impacts of climate change on water systems
 - Reduce flooding and its impacts on lands, communities, and infrastructure
- Wetland Management
 - Identify threats to wetlands and make it easier for ecosystems to adapt to climate change
- Carbon Sequestration
 - Increase natural carbon stores which help remove excess CO₂ from the atmosphere
- Invasive Species
 - Research and monitor invasive species
 - Implement best practices in preventing the spread of invasive species
 - Communicate trends and impacts of invasive species locally
- Protection of Wildlife
 - Mitigate threats to biodiversity
- Monitoring Programs
 - Expand long-term monitoring programs
 - Maintain HCA's planning program as it relates to natural hazards and climate change implications

Experience, Education and Awareness

- Education and Awareness
 - Increase awareness of individual roles in addressing climate change
 - Protect staff and visitor safety

Partnerships

- Strengthen community approach and build systems for collaboration
- Learn from the work of others
- Collaboratively address threats and identify opportunities for climate adaptation and GHG reductions
- Strengthen relationships with Indigenous communities

3.3 Objectives

The goals and objectives that emerged for the constructed wetland project have been assessed, and through further consultation and analysis during this Master Plan process, HCA supports the following long-term objectives for Saltfleet:

1. To conserve, restore, and manage natural heritage features and natural areas in the conservation area.
2. To provide visitors with access to natural areas for passive recreation and education.

3.4 Site Concept

From our background work, consultation, and comments received, these key items were identified for Saltfleet Conservation Area to be addressed in this plan. See maps in Appendix 1 for more information.

.1 Natural Areas

1. To monitor, manage and sustain the wetlands.
2. To fast-track the naturalization of agricultural fields and resource management areas.

.2 Conservation Area

1. To provide access and work areas for site operations.
2. To manage visitation and deter unauthorized access and vandalism.
3. To ensure adequate staffing and resources are provided as visitation increases.
4. To provide a trail system for passive recreation, education, and nature appreciation.
5. To provide educational and interpretive elements focused on the site wetlands, natural areas, natural features (karst) and cultural heritage.



3.5 Policy and By-Law Framework

Conservation areas owned and operated by the HCA are diverse in nature and spread across the watershed. The SCA properties are located at the easterly boundary of HCA's watershed and extend into the Niagara Peninsula Conservation Authority (NPCA) watershed. The properties are also within the Greenbelt Plan and urban boundary of the City of Hamilton. See Section 4.3 for more information.

HCA has approached this Master Plan with the mind-set that other conservation areas in the HCA portfolio requiring Master Plans or updates to Master Plans will follow a consistent

methodology. Although SCA is not located within the jurisdiction of the Niagara Escarpment Commission, the policies of the Niagara Escarpment Plan and guidelines of the Niagara Escarpment Parks and Open Space System (NEPOSS) 2021 planning manual have been observed in the preparation of this Master Plan.

HCA recognizes that certain public infrastructure such as utility corridors, trails, or transportation links may be required to cross conservation area lands. HCA policy for planning review and regulation of these features adheres to the Conservation Authorities Act, R.S.O.1990, C.27. See Section 7.1 for more information.

The Saltfleet Conservation Area Master Plan adheres to policies of the Hamilton Conservation Authority, Niagara Peninsula Conservation Authority, City of Hamilton, and the Province. HCA will consult with outside agencies and obtain the required approvals and permits when implementing projects flowing from this Master Plan.

3.6 Master Plan Zones

HCA has a 10 Year Masterplan Update Strategy that was recently updated by staff and approved by HCA's Board of Directors in 2022. This Strategy applies to all properties that HCA owns and manages. As per this document, guidelines are set out for the completion of HCA Master Plans including Management Plans and Study Areas. This strategy notes that HCA lands that lie within the boundary of the Niagara Escarpment Plan will need Master Plan approval from the Niagara Escarpment Commission (NEC) for HCA to formally ratify them. Consequently, HCA strategically decided to develop all HCA Master Plans within the guidelines of the Niagara Escarpment Parks and Open Spaces System (NEPOSS), which is a requirement of the NEC for any public agency NEPOSS park Master Plans. The NEPOSS policy framework ensures HCA follows a consistent methodology for all plans, and the plans are developed to an appropriate level of detail with sufficient public consultation for all proposed land improvements and uses.

This Master Plan follows the NEPOSS planning manual and identifies six land use zones for SCA. These zones are intended to help guide future planning, development, and management of the conservation area. The zone boundaries are shown in detail in Appendix 1 - Zone Map.

Zones are intended to fulfill a variety of functions in the conservation area, including the following as outlined in the current NEPOSS manual.

- Identification and recognition of the features and attributes (values).
- Protection of key natural heritage and cultural heritage resources.
- Confirmation of the appropriate locations for activities (i.e. directing activities with higher impacts to the least sensitive areas and low impact activities to areas that are more sensitive, if appropriate).
- Delineation of areas based on their requirements for management (e.g. management plan objectives).
- Standardization to support management objectives and actions, based on values (e.g.

Nature Reserve Zones supports protection of sensitive natural heritage features and cultural heritage resources).

- Balancing of public use with the preservation of the natural environment.

There are six types of zones as follows:

- Nature Reserve Zone
- Access Zone
- Development Zone
- Natural Environment Zone
- Cultural Heritage Zone
- Resource Management Zone

The following sections briefly describe each zone. The tables in each section provide a zone description, management direction, and permitted uses, including types of development in each zone. All resource, recreational, and facility development uses are subject to Canadian legislation and policies governing public lands and conservation areas, as well as the resource management policies identified in Section 7.

Appendix 6 contains the natural inventory species lists from background research and field work completed for the preparation of the Master Plan. In this Master Plan, “species at risk” means species listed by the MECP or Government of Canada as threatened, endangered, extirpated or extinct in Ontario including:

- Species designated as endangered, threatened or special concern by the Species at Risk Act (federal) via the Committee on the Status of Endangered Wildlife in Canada (COSEWIC) and listed in Section 5.14.
- Species designated as endangered threatened, or special concern by the Endangered Species Act (provincial) via the Committee on the Status of Species at Risk in Ontario (COSSARO).



Nature Reserve Zone

Nature reserve zones include significant earth and life science features which require management distinct from that in adjacent zones, as well as a protective buffer with an absolute minimum of development. SCA's nature reserve zones contain the existing watercourse and new wetlands.

Table 1. Nature Reserve Zone

Zone	Description	Management Direction	Permitted Uses (subject to management planning)
Nature Reserve (wetland)	<p>Includes the most sensitive natural heritage features and areas that require careful management to ensure long-term protection.</p> <p>Intended to protect in perpetuity features and values of selected life and earth science areas such as:</p> <ul style="list-style-type: none"> ➤ Habitat of endangered, threatened, and rare species or species of special concern. ➤ Significant Wildlife and fish habitat. ➤ Hydrological systems (e.g. streams, wetlands, ponds) ➤ Significant Woodlands ➤ Areas of Natural and Scientific Interest (ANSI) ➤ Significant landforms or escarpment features 	<p>These areas are predominantly natural and should contain naturally functioning ecosystems.</p> <p>This zone is intended to protect and where possible enhance the natural heritage and hydrological systems within the zone.</p>	<p>Sustainable recreational activities that are supported by a detailed environmental review and that are identified as compatible with the natural heritage features and areas of the park or open space.</p> <p>Examples include:</p> <ul style="list-style-type: none"> ➤ Trails ➤ Necessary wayfinding signs ➤ Temporary scientific research ➤ Conservation practices (e.g. tree maintenance, erosion control) ➤ Minimal interpretive facilities (where justified)

Natural Environment Zone

Natural environment zones include natural, cultural, and aesthetic landscapes in which minimum development is permitted to support low-intensity recreational activities. SCA’s natural zones are primarily the undisturbed wooded areas and areas buffering the wetlands.

Table 2. Natural Environment Zone

Zone	Description	Management Direction	Permitted Uses (subject to management planning)
Natural	Includes scenic landscapes in which minimum development is permitted to support recreational activities that have minimal impacts on the Escarpment environment.	<p>This zone may function as a buffer between Nature Reserve Zones and Development Zones, Cultural Heritage, or Access Zones.</p> <p>Management guidance should maintain and enhance the scenic resources and open landscape character of the environment.</p>	<p>Sustainable recreational activities that have minimal impact on the environment may be permitted.</p> <p>Examples include:</p> <ul style="list-style-type: none"> ➤ Trails ➤ Wayfinding signs ➤ Scientific research and supporting facilities ➤ Background campsites ➤ Conservation practices ➤ Interpretive facilities <p>Infrastructure required for safety or accessibility may be permitted where there is no feasible alternative.</p>

Access Zone

Access zones serve as staging areas to support adjacent zones. SCA’s access zones are at the main entrance to the parking lot, at the Dofasco Trail, at the gated service entrance on Second Road, and at the wetlands.

Table 3. Access Zone

Zone	Description	Management Direction	Permitted Uses (subject to management planning)
Access	Serve as staging areas (e.g. trailheads, parking lots) where minimal facilities support the use of Nature Reserve Zones and relatively undeveloped Natural Environment and Cultural Heritage Zones.	Access zones are intended to support the use of and access to adjacent zones.	<p>Infrastructure may be permitted to support the Nature Reserve, Natural Environment, and Cultural Heritage Zone.</p> <p>Examples include:</p> <ul style="list-style-type: none"> ➤ Roads ➤ Wayfinding signs ➤ Interpretive signs ➤ Trailheads ➤ Parking lots ➤ Visitor amenities ➤ Toilets ➤ Waste receptacles

Cultural Heritage Zone

Cultural heritage zones are intended to protect significant built heritage resources, archaeological resources, and cultural heritage resources. SCA’s cultural heritage zone includes the registered archaeological sites.

Table 4. Cultural Heritage Zone

Zone	Description	Management Direction	Permitted Uses (subject to management planning)
Cultural Heritage	This zone includes cultural heritage resources that require management to ensure long-term conservation.	Management guidance will ensure long-term conservation, enhancement and potentially restoration of cultural heritage resources.	<p>Development will ensure long-term conservation of cultural heritage resources.</p> <p>Examples include:</p> <ul style="list-style-type: none"> ➤ Education and visitor buildings ➤ Trails ➤ Interpretive signs or supporting infrastructure ➤ Historical restorations, reconstructions, or re-enactments



Development Zone

Development zones provide visitor access, orientation, and operational facilities in the conservation area. SCA's development zones includes the park roads, main parking area, and work areas for conservation area operations.

Table 5. Development Zone

Zone	Description	Management Direction	Permitted Uses (subject to management planning)
Development	<p>Development Zones provide the main visitor access to the conservation area, and facilities and services to support nature appreciation and recreational activities.</p> <p>This zone may include areas designed to provide facilities and supporting infrastructure for recreational purposes.</p>	<p>Management guidance should note that recreational uses and development may be accessory or secondary to the protection of natural heritage features and to the conservation of cultural heritage resources, depending on classification.</p> <p>Retail and visitor facilities should be appropriately scaled for the site.</p> <p>Facility development must be undertaken in a way that will minimize the impact on the Escarpment environment.</p>	<p>Examples of permitted uses that provide access, orientation and operational facilities to support nature appreciation and recreational activities include:</p> <ul style="list-style-type: none"> ➤ Educational and visitor buildings ➤ Recreational infrastructure ➤ Commercial/retail service facilities ➤ Special purpose buildings ➤ Research buildings ➤ Maintenance buildings ➤ Parking lots ➤ Road networks

Resource Management Zone

Resource management zones provide for sustainable resource management of agricultural lands, previously disturbed sites, forest products, and land that has a long-term resource agreement such as a managed forest. SCA's resource management zones include the former agricultural lands.

Table 6. Resource Management Zone

Zone	Description	Management Direction	Permitted Uses (subject to management planning)
Resource Management	<p>Provides for sustainable resource management of forests, fisheries, watersheds, wildlife, or flood control.</p> <p>Previously disturbed sites (e.g. old farm fields, abandoned quarries) where active measures are being taken to re-establish natural vegetation.</p> <p>May include land that has traditionally been managed under long-term resource agreements (e.g., forest management agreements or agricultural leases)</p>	<p>Management guidance should support:</p> <ul style="list-style-type: none"> -Experimenting with alternative resource management practices. - Understanding ecosystem structures and functions. - Activating effective conservation and stewardship practices. 	<p>These areas may be used to demonstrate ecologically sustainable resource management practices.</p> <p>Examples may include:</p> <ul style="list-style-type: none"> ➤ Research monitoring plots ➤ Forest management ➤ Fisheries management ➤ Wildlife management ➤ Watershed management ➤ Flood control <p>Recreation uses in this zone are subject to HCA policies and management planning.</p>

3.7 Development Priorities

The capital development priorities and estimates of development costs for SCA over the next ten years are listed in Appendix 2 and shown in Appendix 1 – Maps 6 & 7.

All development projects are to be reviewed annually for the life of this Master Plan, and the capital development priority list updated as necessary. Capital projects should not be started until a long-term strategy with timelines and costs for each project are clearly defined and sufficient resources are available to complete them. See Section 8.2 for further information.

Significant capital development for SCA over the next ten years falls within these categories:

.1 Natural Areas:

To conserve, restore, and manage natural heritage features and natural areas in the conservation area:

- Provide additional wetland plantings for the BC-1 and SC-8 sites to support their establishment.
- Complete constructed wetlands for the SC-8 site as per approved studies.
- Provide additional tree and shrub plantings to support natural areas restoration.
- Naturalize the agricultural fields as quickly as possible.
- Manage invasive species.

.2 Conservation Area Improvements:

To manage both the natural areas and public visitation in the conservation area:

- Install perimeter fencing and buffers to restrict unauthorized access.
- Install perimeter service gates for emergency and maintenance access.
- Install site signage.

.3 Site Concept Improvements:

To provide visitors with access to passive recreational opportunities and connect to other conservation lands:

- Provide a new visitor entrance road and parking lot.
- Implement an automated gate system for parking.
- Provide public washrooms.
- Provide for operation areas separate from the main entrance.



- Provide a new multi-use recreational trail system.
- Provide open air structures: trail kiosks, pavilion.
- Install main entrance signage.
- Provide interpretive signage and educational materials.
- Provide lookout stations.
- Provide site furnishings for the main parking area and Dofasco Trail connection.



4.0 BACKGROUND

4.1 Study Area

Saltfleet Conservation Area (SCA) is located at 444 First Road East, Stoney Creek, City of Hamilton. There are also five other properties on top of the Niagara Escarpment in Stoney Creek associated with SCA. All six land parcels total 147 ha (363 acres) in size, two of these parcels are outside of HCA's watershed. The acquisition of these lands was made possible through donations from the City of Hamilton, Heritage Green Community Trust, and the Hamilton Conservation Foundation.

Figure 2 Master Plan Study Area Map, shows the overall study area and HCA landholdings associated with SCA. This Master plan is part of a ten-year strategy for reviewing HCA lands across the watershed. HCA staff are following this strategy to systematically glean valuable scientific data and site information from targeted study areas and using this information in the preparation of master and management plans.

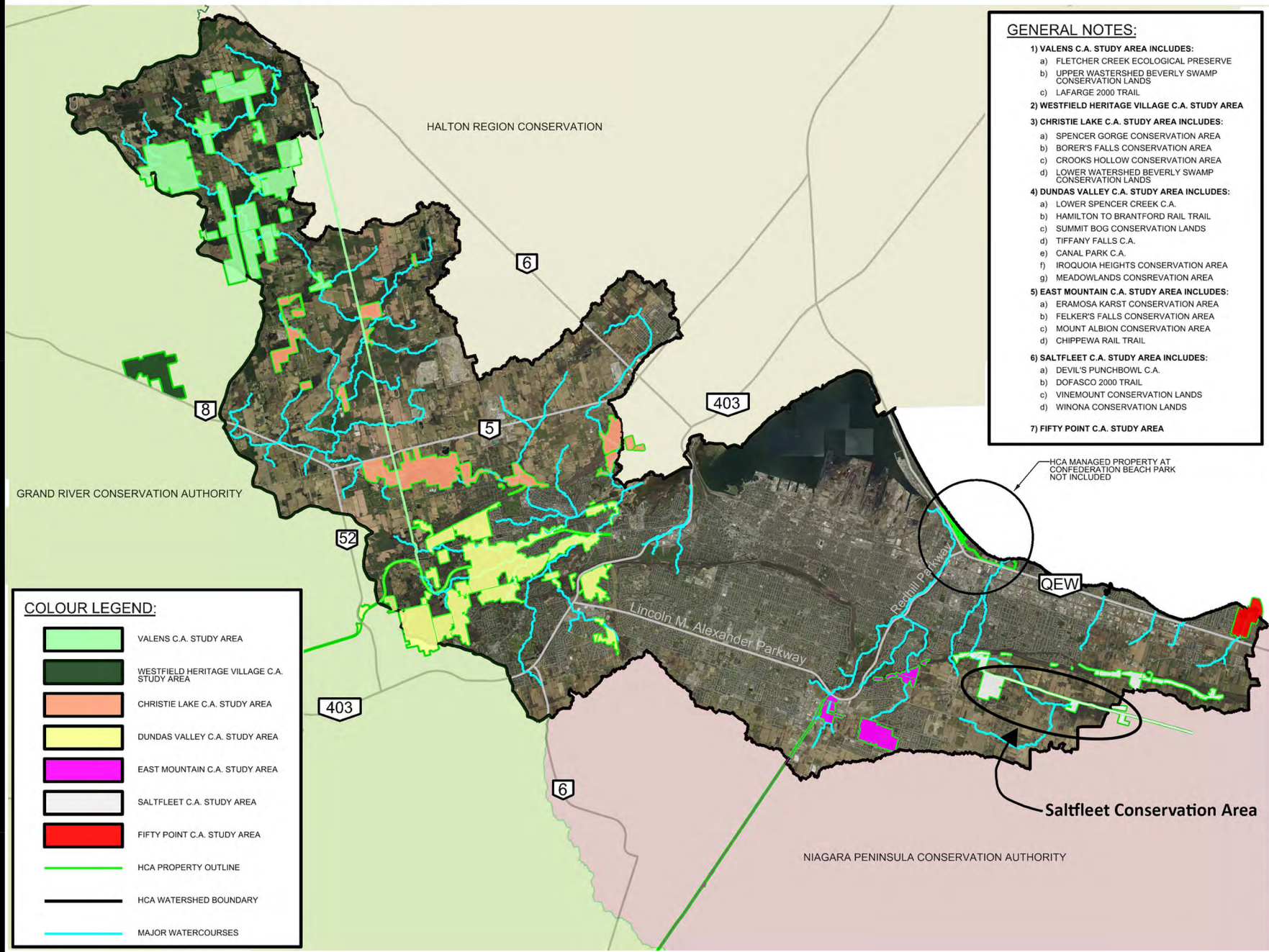
The main focus of this Master Plan is the 73.7 ha (182 acres) SCA property bounded by First Road East, the Dofasco 2000 Trail, Second Road East and Green Mountain Road East. The property was previously farmed and is reverting to natural habitat. Two main features on the property are Battlefield Creek which flows from east to west across the site, and a low escarpment south of the creek which divides the property into a lower and upper portion. The upper portion south of the creek is predominantly composed of fallow fields and hedgerows. The crest of the low escarpment is vegetated with a variety of trees and grasses. The low area near the creek is more varied and contains swamp, thicket, and meadow areas.

New wetland construction (BC-1) started at SCA in February 2022 and was completed by September 2022. The wetlands are designed to hold large volumes of water. A smaller constructed wetland (SC-8) is being planned for the 9 ha (22 acres) parcel at the southwest corner of Green Mountain and Fifth Road east.

The main SCA property currently contains an entrance lane (former farm entrance) to a small day-use parking area. A single trail connects to the Dofasco 2000 Trail and Devil's Punchbowl Conservation Area from this area.













FIGURE 2. HCA 10-YEAR MASTER PLAN STUDY AREA



- GENERAL NOTES:**
- 1) VALENS C.A. STUDY AREA INCLUDES:**
 - a) FLETCHER CREEK ECOLOGICAL PRESERVE
 - b) UPPER WATERSHED BEVERLY SWAMP CONSERVATION LANDS
 - c) LAFARGE 2000 TRAIL
 - 2) WESTFIELD HERITAGE VILLAGE C.A. STUDY AREA**
 - 3) CHRISTIE LAKE C.A. STUDY AREA INCLUDES:**
 - a) SPENCER GORGE CONSERVATION AREA
 - b) BORER'S FALLS CONSERVATION AREA
 - c) CROOKS HOLLOW CONSERVATION AREA
 - d) LOWER WATERSHED BEVERLY SWAMP CONSERVATION LANDS
 - 4) DUNDAS VALLEY C.A. STUDY AREA INCLUDES:**
 - a) LOWER SPENCER CREEK C.A.
 - b) HAMILTON TO BRANTFORD RAIL TRAIL
 - c) SUMMIT BOG CONSERVATION LANDS
 - d) TIFFANY FALLS C.A.
 - e) CANAL PARK C.A.
 - f) IROQUOIA HEIGHTS CONSERVATION AREA
 - g) MEADOWLANDS CONSERVATION AREA
 - 5) EAST MOUNTAIN C.A. STUDY AREA INCLUDES:**
 - a) ERAMOSIA KARST CONSERVATION AREA
 - b) FELKER'S FALLS CONSERVATION AREA
 - c) MOUNT ALBION CONSERVATION AREA
 - d) CHIPPEWA RAIL TRAIL
 - 6) SALT FLEET C.A. STUDY AREA INCLUDES:**
 - a) DEVIL'S PUNCHBOWL C.A.
 - b) DOFASCO 2000 TRAIL
 - c) VINEMOUNT CONSERVATION LANDS
 - d) WINONA CONSERVATION LANDS
 - 7) FIFTY POINT C.A. STUDY AREA**

COLOUR LEGEND:

	VALENS C.A. STUDY AREA
	WESTFIELD HERITAGE VILLAGE C.A. STUDY AREA
	CHRISTIE LAKE C.A. STUDY AREA
	DUNDAS VALLEY C.A. STUDY AREA
	EAST MOUNTAIN C.A. STUDY AREA
	SALT FLEET C.A. STUDY AREA
	FIFTY POINT C.A. STUDY AREA
	HCA PROPERTY OUTLINE
	HCA WATERSHED BOUNDARY
	MAJOR WATERCOURSES



DATE: 2023/01/27

MASTER PLAN STUDY AREA MAP



4.2 Property History

See Section 4.6 for more information on the cultural heritage study for Saltfleet.

The Battlefield and Stoney Creek Watersheds (see Figure 3 Subwatersheds) drain approximately 3089 ha at the outlet to Lake Ontario. Property development above and below the Niagara Escarpment was typically implemented without stormwater management controls, resulting in increased flow rates within the Battlefield and Stoney Creek watercourses. In recent history (from 1989 onward), flooding and erosion conditions along the lower Stoney Creek and Battlefield Creek impacted private property and municipal infrastructure in the City of Hamilton. Further detailed study was required to properly assess which flood and erosion controls would be effective to address this problem.



In support, HCA completed the 2011 ‘Draft’ Conservation Ontario Class Environmental Assessment (2011 Draft EA) for the Lower Stoney Creek and Lower Battlefield Creek (reference AMEC, 2011). This EA identified a number of properties in the Community of Stoney Creek below the escarpment that were at risk due to flooding, and to a lesser degree erosion. The Class EA concluded that substantial water storage would be required to address the flood risk and additional study would be warranted to determine the efficacy of storage systems (facilities) to address flood and erosion risks.

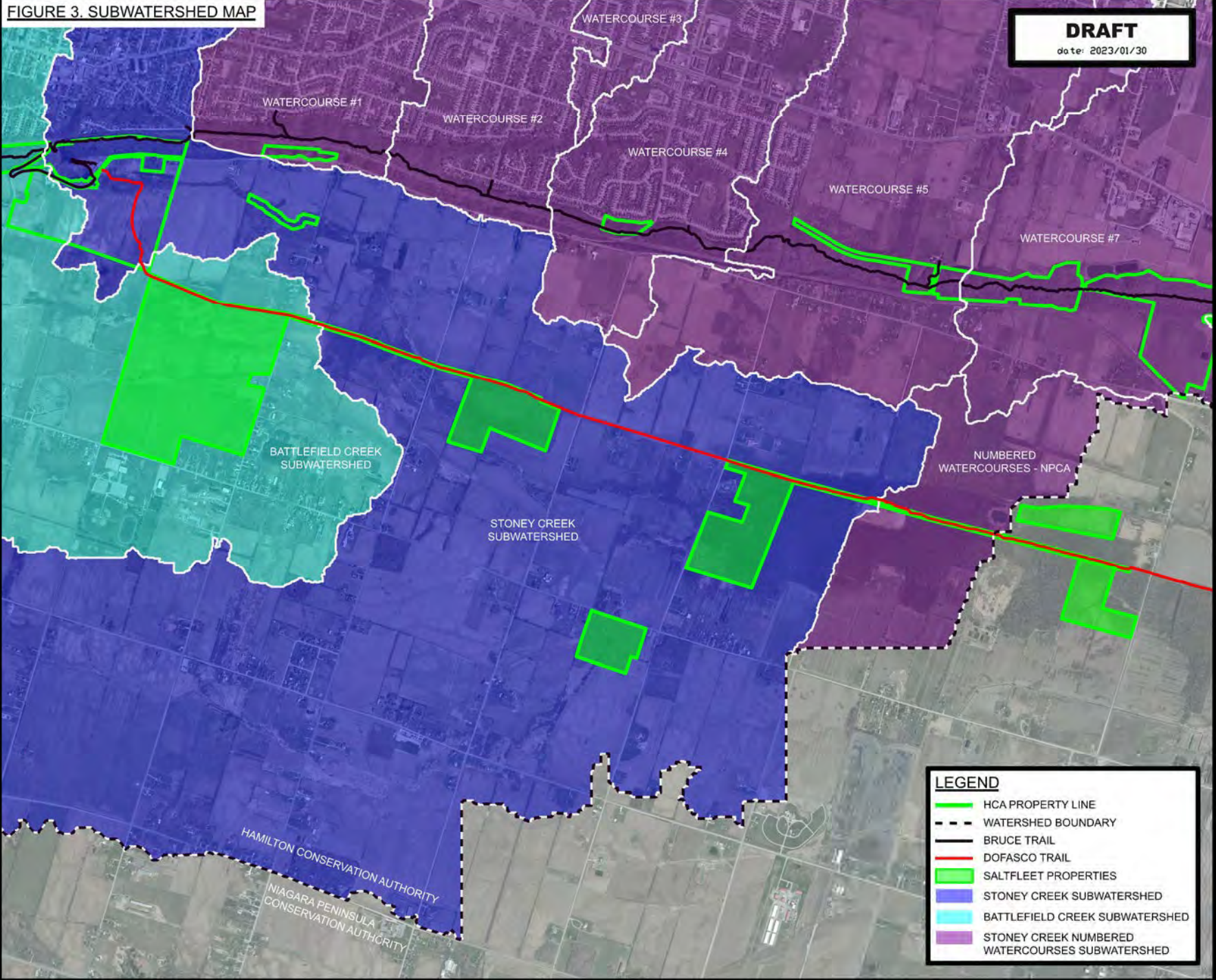
Flowing from the 2011 Draft EA recommendations, HCA staff investigated areas above the Escarpment that could help provide flood attenuation. Through this investigation, as well as reviewing technical studies of this area completed since the 1970’s, staff determined that land acquisition would be required for water storage, and set out the following goal:

“To create a new conservation area in the east end of the City of Hamilton, specifically the Upper Stoney Creek and Upper Battlefield Creek watersheds above the Niagara Escarpment to provide natural hazard attenuation, natural heritage enhancements and recreation opportunities.” (East Escarpment Conservation Area, February 2015).

The study further set out stages that would be required to implement this goal: acquire funding for land securement; acquire land and develop more detailed plans for natural heritage conservation and restoration; and complete natural hazard attenuation studies for the acquired lands to determine how natural hazards (flooding) can be addressed.

In 2014 HCA’s Board of Directors directed staff to pursue potential funding sources for land securement. Staff reported back to the Board in August 2014 that funding totaling \$4.75M was to be secured through the Heritage Green Community Trust, the City of Hamilton, the Hamilton Conservation Foundation, and the HCA Land Acquisition Fund. Board approval was granted for the land acquisition project to proceed.

FIGURE 3. SUBWATERSHED MAP



DRAFT
date: 2023/01/30



DATE: 2023/01/30

**SUBWATERSHEDS
SALTFLEET C.A. MASTER PLAN**

LEGEND

- HCA PROPERTY LINE
- WATERSHED BOUNDARY
- BRUCE TRAIL
- DOFASCO TRAIL
- SALTFLEET PROPERTIES
- STONEY CREEK SUBWATERSHED
- BATTLEFIELD CREEK SUBWATERSHED
- STONEY CREEK NUMBERED WATERCOURSES SUBWATERSHED



HCA struck a working committee following the Board meeting, and property acquisition proceeded from 2015 to 2016 to assemble the land parcels noted in this plan.

Building on lands acquired and ongoing land acquisition efforts, in 2018 HCA completed the Flood and Erosion Control Project Class Environmental Assessment (Amec Foster Wheeler). This provided sufficient natural heritage conservation and restoration background information for the SCA constructed wetland project to be developed further.

In 2021 HCA completed the Battlefield Creek Wetland Storage Facility Design Report (BC-1), and the BC-1 wetland detailed design drawings (Water's Edge) for the Saltfleet constructed wetland project. The detailed information compiled in the report and on the design drawings has been reviewed and incorporated into this Master Plan.

HCA staff began site preparations at SCA in 2018 for the future wetland projects. A dedication plaque to Jim Howlett was installed in the parking area in 2019 in recognition of his unprecedented service to HCA, having served on every committee, advisory board and board of directors that HCA has had over the last twenty years. Mr. Howlett was a champion for SCA, having visited the site when it was still a working farm, and a strong proponent of expanding HCA's land holdings in the eastern reaches of the watershed.



The site was officially opened on October 2, 2021, using the existing farm lane as an entrance, to a parking area cleared from the former farm occupation. The site closed in the winter of 2021-22 to prepare for the wetland construction project. Wetland construction commenced in the spring and was completed late summer 2022. The site re-opened again to the public September 23, 2022.

4.3 Planning and Development Controls

SCA is located in the City of Hamilton (Stoney Creek) Ward 9, formerly the Township of Saltfleet.

See Figure 4 City of Hamilton Zoning for the location of the zoning areas as described below.

The Saltfleet Conservation Area BC-1 property is under the City of Hamilton's Rural Official Plan (OP, City of Hamilton 2018) and Stoney Creek Zoning By-law, Ward 9, and is classified as Rural Land Use 'Specialty Crop' and zoned A1 Agricultural and P6 Conservation/Hazard Land. The

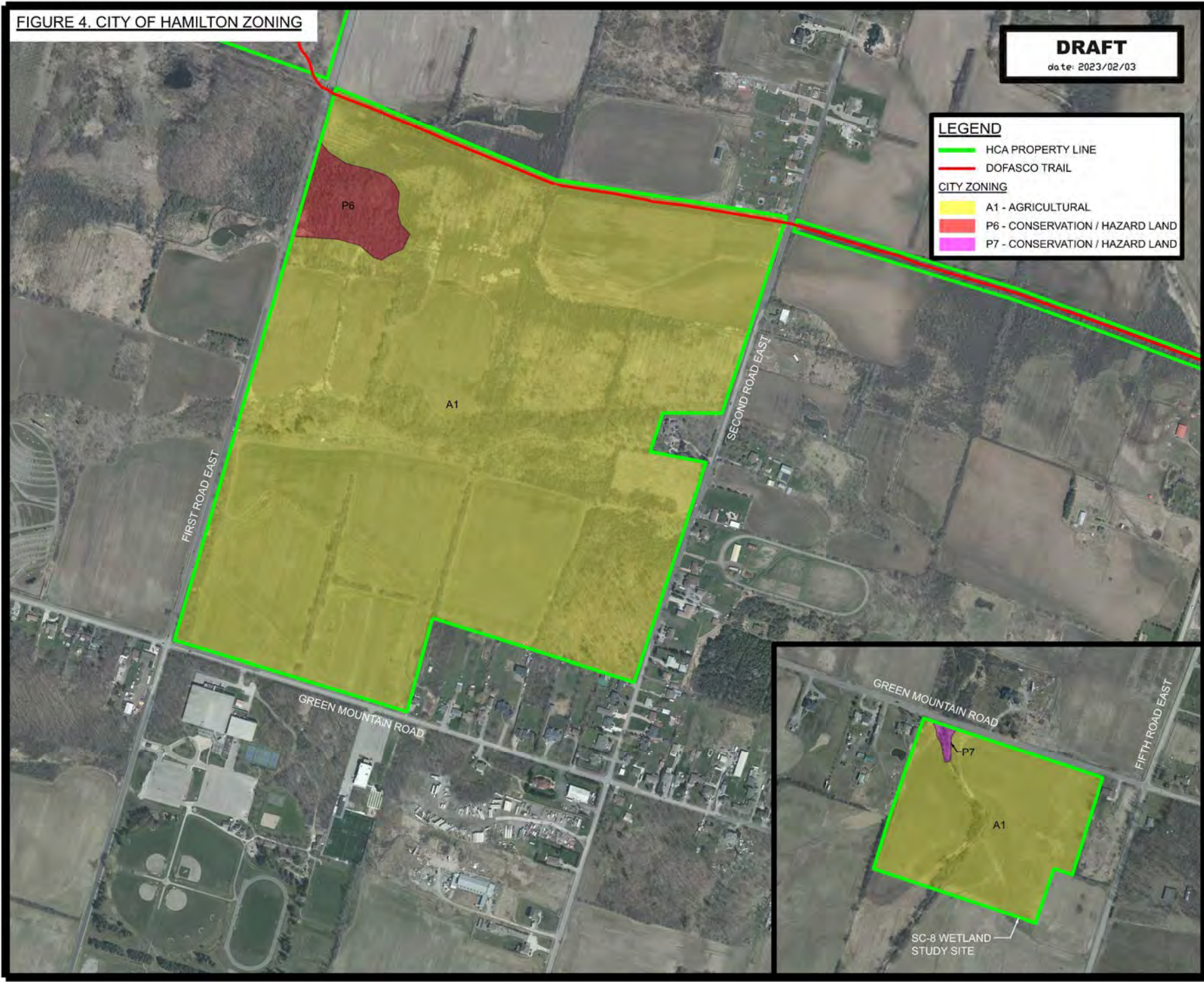
Agricultural Zone (A1) is the major area of the SCA property, formerly farmed. The Conservation/Hazard Land Zone (P6) applies to the wooded area northwest of the creek.

The SC-8 property is also largely zoned as Agricultural (A1), with Conservation/Hazard Land (P7) zoning along a portion of the creek where it crosses Green Mountain Road.

The City zoning regulations prescribe permitted uses, setbacks for buildings and parking areas, and the wetland areas as mapped by the Hamilton Conservation Authority. The City of Hamilton planning department has been consulted and their comments addressed in the preparation of this Master Plan.

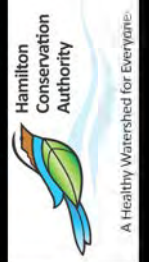


FIGURE 4. CITY OF HAMILTON ZONING



DATE: 2023/02/03

**CITY OF HAMILTON ZONING
SALTFLEET C.A. MASTER PLAN**



In the Rural Hamilton Official Plan several natural heritage designations are identified for the SCA property including:

- The entire property is part of the Greenbelt Protected Countryside.
- HCA staff contributed to the Greenbelt Foundation paper “Investing in the Future: The Economic Case for Natural Infrastructure in Ontario” (reference Anielski Management Inc. 2019) for Saltfleet Conservation Area. This paper concluded that “the Saltfleet Conservation Area and the associated wetland restoration has a strong business case and the benefits this project will provide to the community are likely to extend beyond the 50-year return period used in this analysis.”
- The Niagara Escarpment Plan Area is immediately north of the property adjacent to the Dofasco 2000 Trail.
- The property contains a portion of the headwaters of Battlefield Creek, considered a key hydrologic feature - streams.
- The treed area in the northwest is considered a Natural Heritage Features Core Area, Key Natural Heritage Feature - Significant Woodlands, and is part of the Greenbelt Natural Heritage System.
- The treed area in the southeast near Green Mountain Road is considered a Natural Heritage Feature - Linkages.
- In addition, the following applicable policies, legislation, and planning studies are relevant for any work to be contemplated on the property:
- Provincial Policy Statement (PPS) under the Planning Act which have implications for Significant Woodland, Fish habitat, Significant Wildlife Habitat, habitat for Species at Risk.
- Ontario Endangered Species Act which has implications for endangered and threatened species and their habitat observed on the properties.
- Canada Migratory Birds Convention Act which protects numerous bird species and their breeding season generally extending between late March to August. Timing of construction activities and especially vegetation clearing must take this act into account.
- Ontario Heritage Act governing lands which contain archaeological resources or areas of archaeological potential.
- Canadian Fisheries Act for any work completed in the vicinity of Battlefield Creek.
- Ontario Fish and Wildlife Act.
- Conservation Authorities Act, R.S.O. 1990.
- Rural Hamilton Official Plan.
- City of Hamilton Rural Private Tree By-Law.
- Ministry of Environment, Conservation and Parks Environmental Protection Act.

Representatives from the Niagara Escarpment Commission; Ministry of Natural Resources and Forestry; and the NPCA have been consulted in the preparation of this Master Plan.

As shown in Figure 5 Policy Areas, there are planning and development controls in the area that are restricting development near SCA. These include the Greenbelt Plan and Niagara Escarpment Plan. Accordingly, there are very few active development applications in the study area or near the conservation area of concern.

A review of demographic trends reveal over the lifespan of this Master plan population growth is estimated to add 68 thousand more residents within 15 minutes travel to the conservation area (2022 City of Hamilton Recreation Master Plan). See Section 8 for more information.

4.4 Buildings

See Sections 4.6 and 4.7 for site historic information and Figure 6 for structures and karst feature locations.

When HCA acquired the SCA property only a few structural items and debris were left from the former farm occupation. Debris piles were found near the entrance gate and parking area which HCA staff removed to open the laneway and parking area to the public. Remnant farm features of interest for further interpretation include the stone silo and stone wall near the karst stream, and the silo and building foundation ruins. Further study of these areas is recommended.



FIGURE 5. POLICY AREAS

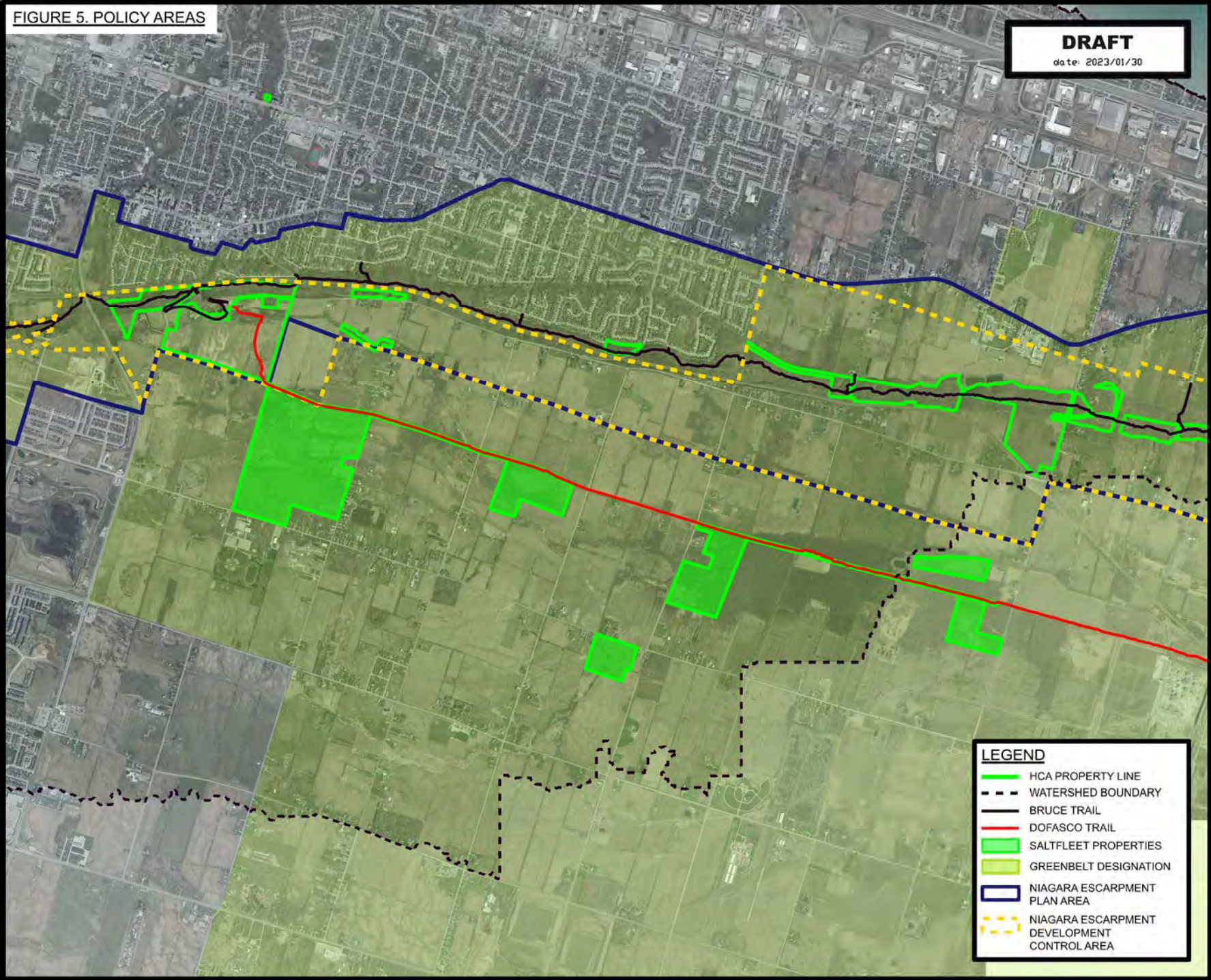
DRAFT

date: 2023/01/30



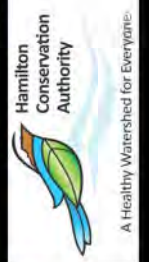
DATE: 2023/01/30

**POLICY AREAS
SALTFLEET C.A. MASTER PLAN**



LEGEND

- HCA PROPERTY LINE
- WATERSHED BOUNDARY
- BRUCE TRAIL
- DOFASCO TRAIL
- SALTFLEET PROPERTIES
- GREENBELT DESIGNATION
- NIAGARA ESCARPMENT PLAN AREA
- NIAGARA ESCARPMENT DEVELOPMENT CONTROL AREA



4.5 Physical Features

With the exception of the wooded area in the northwest corner of the SCA property, the land was cleared and in agricultural use in 1943 based on aerial photographs in the McMaster University Air Photo collection. The site is no longer being farmed and is reverting to natural habitat.

The main channel of Battlefield Creek flows from east to west across the northern portion of the property. The south half of the property forms a gently undulating plateau with elevations ranging from about 206 meters above mean sea level (mASL) along Green Mountain Road, to about 201 mASL along the crest of the low escarpment (the Eramosa escarpment or scarp) oriented east-west at about the mid-point of the property.

Vegetation cover in this half of the property is predominantly composed of row crops and hedgerows while the crest of the low escarpment is vegetated with a variety of trees and grasses.

From the low escarpment, the ground surface slopes steeply to a second plateau to the north at about 190 mASL elevation. Vegetation in this north half of the property is more varied and consists of deciduous swamp, cultural thicket, meadow marsh, and cultural meadow. Runoff from the Eramosa scarp follows an intermittent channel to Battlefield Creek.

Within the broader study area, the dominant topographic feature is the Niagara Escarpment which is located between 750 and 800m north of the conservation area. The Escarpment marks the boundary between the resistant dolostone bedrock to the south and the more easily eroded shales which occur at the base of the escarpment and underlie the lake plain north to Lake Ontario. The elevation drops over 100m between the crest of the Escarpment and the shores of Lake Ontario.

The site contains karst topography that affects drainage patterns on site. The most noticeable karst features are the seeps at the base of the Eramosa Escarpment in the middle of the site, the sinkhole in the open field south of the main entrance with a disappearing stream, and the stream that flows from the base of ridge. Infiltration and runoff are difficult to separate, and infiltrated precipitation may break out in springs as secondary runoff. Noticeable karst features are noted on Figure 6 Structures and Karst Features. Further investigation of the karst features is recommended in the capital projects plan, see Section 8.2.



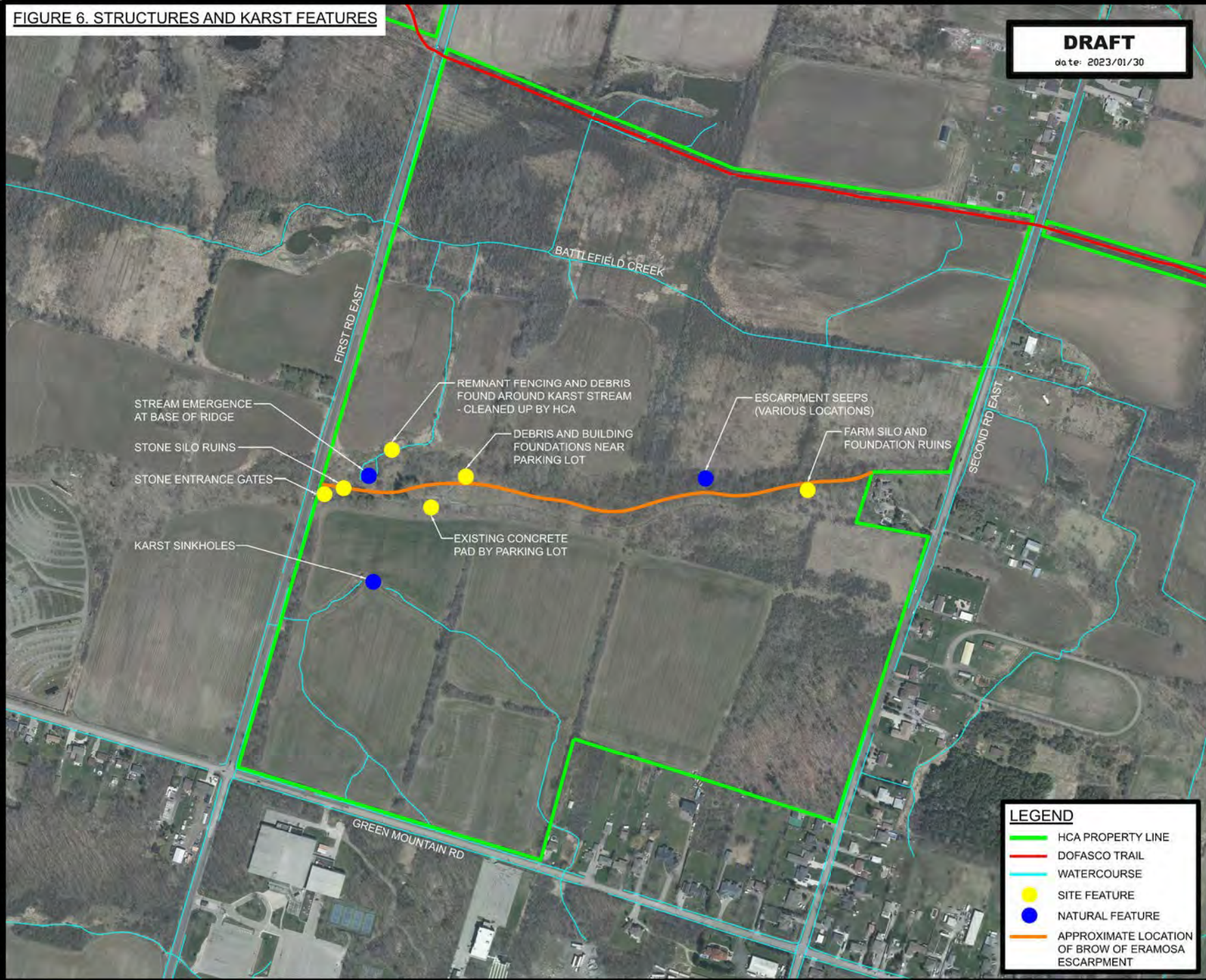
FIGURE 6. STRUCTURES AND KARST FEATURES

DRAFT

date: 2023/01/30



DATE: 2023/01/30



**STRUCTURES AND KARST FEATURES
SALTFLEET C.A. MASTER PLAN**

LEGEND	
	HCA PROPERTY LINE
	DOFASCO TRAIL
	WATERCOURSE
	SITE FEATURE
	NATURAL FEATURE
	APPROXIMATE LOCATION OF BROW OF ERAMOSA ESCARPMENT



4.6 Cultural Heritage

The information in this section focuses on the main Saltfleet property. Quoted text has been excerpted from the archaeological assessments conducted between 2020 to 2021 by consultants from Detritus Consulting Ltd, Kitchener Ontario. HCA retained the consultants for the environmental assessment for the constructed wetland design project. Modifications and additions have been made following consultation with local First Nations.

.1 Pre-Contact First Nations Land Use

“This portion of Southwestern Ontario has been demonstrated to have been occupied by people as far back as 11,000 years ago as the glaciers retreated. For the majority of this time, people were practicing hunter gatherer lifestyles with a gradual move towards more extensive farming practices.” (Detritus Consulting Ltd., 2021). Registered archaeological sites within this study area have confirmed pre-contact First Nations land use, as well as post-contact Euro Canadian land use.

The HCA recognizes that these conservation area lands were inhabited by First Nations peoples including the Mississaugas of the Credit First Nation, the Haudenosaunee, and the Huron-Wendat. The HCA also recognizes that this area has been, and continues to be, home to many Indigenous Peoples including the Métis, Inuit and Urban Indigenous communities.

A Stage 2 archaeological assessment of the property discovered Pre-Contact First Nations stone artifacts (projectile points, tools and fragments of tool making). Interpretation of the artifacts by the archaeological consulting team concluded this was a small activity area occupied by unspecified First Nations people during the Pre-Contact period.

A Stage 3 site specific archaeological assessment was completed for one site which could potentially be impacted by future entrance laneway and parking lot improvements. During the Stage 3 assessments, representatives from the Six Nations of the Grand River First Nation, the Mississaugas of the Credit First Nation, and the Haudenosaunee Development Institute participated as monitors, alongside the archaeological team retained by HCA. The following recommendations from the assessment flow from this engagement:

- Assessed archaeological sites are to be documented on all contract drawings for the BC-1 wetland project. The location of these sites is shown on the appended maps for this Master Plan. See Appendix 1 maps noting these locations in the conservation area zoning for this Master Plan.
- That long term protection for the archaeological sites be implemented and mechanisms such as restrictive covenants be placed on the property title to prohibit activities that may alter sites either temporarily or permanently. HCA has placed a restrictive covenant on the SCA property protecting the documented archaeological sites, see Section 4.7.
- That soil disturbance, other than normal agricultural practice, not occur. Minor landscaping activities on or above the surface of the site including the addition of topsoil up to 50cm maximum fill (combined existing and new fills), farming, and grass cutting are permissible. See Section 7.1 for inclusion of this information in the site management.

.2 Post-Contact First Nations Land Use

“The earliest recorded visit to the Niagara region [by a European] was undertaken by Etienne Brûlé, an interpreter and guide for Samuel de Champlain.... The purpose of this endeavour was to establish good relations with [First Nations] communities in advance of future military and colonial enterprises in the area.” (Detritus Consulting Ltd., 2021). Throughout the middle of the 17th century, “a series of bloody conflicts followed known as the Beaver Wars, or the French and Iroquois Wars, contested between the Iroquois confederacy and the Algonkian speaking communities of the Great Lakes region. Many communities were destroyed including the Huron, Neutral, Susquehannock, and Shawnee” (Detritus Consulting Ltd., 2021).

“The late 17th and early 18th centuries represent a turning point in the evolution of the post-contact [First Nations] occupation of Southern Ontario. It was at this time that various Iroquoian-speaking communities began migrating from New York State, followed by the arrival of new Algonkian-speaking [First Nations] from northern Ontario (Konrad 1981; Schmalz 1991). More specifically, this period marks the arrival of the Mississaugas into Southern Ontario” (Detritus Consulting Ltd., 2021). “...at the end of the 17th century, the Mississaugas' settled permanently in Southern Ontario.... Around this same time, members of the Three Fires Confederacy (Chippewa, Ottawa, and Potawatomi) began immigrating from Ohio and Michigan into southwestern Ontario (Feest and Feest 1978:778-79).” (Detritus Consulting Ltd., 2021).

Saltfleet Township is part of the Between the Lakes Purchase (Treaty 3) which was originally signed in 1784 between the Crown and the Mississauga peoples (Ontario Ministry of Indigenous Affairs, 2018). The 'Between the Lakes Purchases' of 1784 and 1792 (Archives of Ontario, 2009) established the formation of Upper Canada in 1792 from Essex in the west to Glengarry in the East. The part of Ontario where Saltfleet is located is also known to be covered under the 1701 Nanfan Treaty or Albany Deed.

.3 Euro-Canadian Land Use

“The Township of Saltfleet was established in Lincoln County in 1791 and became part of Wentworth County in 1816. The name Saltfleet was taken from the village of Saltfleet in Lincolnshire England (Hamilton Public Library 2017). Settlement began to trickle into the region in 1786, with an influx of loyalist immigrants from New York State began immigrating to Upper Canada in the years following the Revolutionary War. The Township of Saltfleet was laid out in eight concessions between Lake Ontario and the Township of Binbrook to the south. After the American Revolutionary War, Crown Patents were granted to United Empire Loyalists who settled at first below the escarpment but soon spread south of the escarpment creating small hamlets such as Albion and Elfrida.” (Detritus Consulting Ltd., 2021).

“The Illustrated Historical Atlas of the County of Wentworth, Ont. (Historical Atlas), demonstrates the extent to which Saltfleet Township had been settled by 1875 (Page & Smith 1875; Figure 2). Landowners are listed for every lot within the township.... Also visible is the community of Stoney Creek, located northwest of the Study Area. To the southwest of the Study Area is the community of Elfrida, to the west Mt. Albion and to the southeast, Tapleystown.” (Detritus Consulting Ltd., 2021). Due to this amount of settlement, the potential for Post-Contact and Euro-Canadian material evident in the study area is deemed to be

moderate to high.

The Historical Atlas does not accurately locate or depict structures on the maps, and landowners were not always listed on the maps. However, cursory review of the historic records indicates farm lands owned by G.R. Davis. It is possible that the remains of the farmstead in the conservation area are from the Davis occupation. Further research is recommended for interpretation of the farmstead artifacts visible on site.



A Stage 1 and Stage 2 archaeological assessment were completed for the entire site, and six sites with First Nations or Euro-Canadian attributes were discovered. At the end of the Stage 2 process, an “avoid and protect” approach was implemented, as no wetland construction work was proposed in these six areas. The areas were surveyed and restrictive covenants with 70m or 10m setbacks were put in place. A Stage 3 assessment was completed for one site which could potentially be impacted by future entrance laneway and parking lot improvements.

All Artifacts collected during these assessments are currently being held by the archaeological consultants pending transfer to Her Majesty the Queen in right of the Province of Ontario, or another suitable public institution acceptable to the Ministry of Heritage, Sport, Tourism and Culture Industries (MHSTCI) and the site’s owners. Artifacts of Euro-Canadian origin discovered include ceramic sherds, bottle glass, window glass, cut nails, brick and personal items. The artifacts date from the mid to late 19th century.

4.7 Heritage Designation and Historic Buildings

The Ontario Heritage Act enables municipalities to protect and manage Ontario’s cultural heritage resources. Part IV of the Act provides for municipal designation of individual properties as having cultural heritage value. Properties are designated by a municipal by-law, with reasons for designation or a description of heritage attributes which must be retained to conserve the cultural heritage value. Heritage property designation serves to: recognize the importance of a property to the community; identify and protect the property’s cultural heritage value; encourage good stewardship and conservation; and promote knowledge and understanding about the property and the development of the community.



As noted in Section 4.6, archaeological assessments were conducted at SCA for the constructed wetland project. Six archaeological sites of cultural heritage value and interest were recommended by the archaeological consultants for long term protection, these sites are shown on the maps in Appendix 1. HCA agreed with these recommendations and on February 1st, 2022, had a restrictive covenant placed on the property title for the archaeological sites. This covenant states that:

“no person, knowing that this is an archaeological site, shall alter the site. No artifacts or any other physical evidence of past human use or activity shall be removed from the site without a license as provided for under Section 48(1) of the Ontario Heritage Act. Under Section 48(3) of the Ontario Heritage Act, the restriction on alteration or the removal of an artifact or other physical evidence of past human use and activity from the site will no longer apply when a licensee has completed archaeological fieldwork within the meaning of the regulations on the site and an archaeological report has been provided to the Minister stating that the site has no further cultural heritage value or interest and the report is entered into the Ontario Public Register of Archaeological Reports. Any alterations or soil disturbance to an archaeological site prior to having met the requirements of Section 48(3) is an offence subject to penalty under Section 69(1) of the Ontario Heritage Act. For further clarity, minor landscaping activities on or above the surface of the site including the addition of topsoil up to 50cm maximum fill (combined new and existing fills) over the site, farming, and grass cutting are not considered to be alterations for the purpose of this covenant.”

4.8 Natural Areas

SCA's natural areas include Environmentally Significant Areas (ESAs), significant woodlands, Provincially Significant Wetlands, escarpment, karst, and managed forest. SCA contains physical features, flora and fauna of significance along with cultural heritage sites, former agricultural land that is naturalizing and both natural and constructed watercourses and wetlands.

All future development from this Master Plan is to follow the Master Plan zone guidelines outlined in Section 3.6, and the natural areas recommendations noted in Section 5.16.



5.0 NATURAL AREAS INVENTORY

Information in this section focuses on studies conducted on the SCA property bounded by First Road East, the Dofasco 2000 Trail, Second Road East and Green Mountain Road East. Sub-surface investigations were conducted for the wetland project in the spring of 2019, which included nine sampled boreholes and ground monitoring wells. An overview of the investigations is provided in this section for general information and understanding. HCA has the full investigation reports on file, they are referenced in Appendix 7.

5.1 Physiography and Topography

The study area is located on the Waterdown moraine with glacial tills dominating the soil stratigraphy. The tills extend into dolomite bedrock of Amabel Formation.

During the waning stages of the Wisconsinan glaciation, a series of glacial deposits were laid down over the older strata and bedrock. The surficial geology of the property is dominated by a stratum of glaciolacustrine silty clay with accumulations of organic soils (topsoil and peat) in low lying areas, and exposed bedrock in small areas where water erosion has removed the overburden cover.

The bedrock geology is comprised of Paleozoic sedimentary rocks that were laid down as marine sediments in the Iapetus Ocean (pre-cursor to the Atlantic). The Niagara Escarpment was created by differential erosion within the softer shales of the Queenston Formation, and the hard dolostones of the Lockport Group. Bedrock geology of the study area is shown in Figure 7, Conceptual Geological Section. The Eramosa scarp formation in the conservation area is at the division of the softer and more erodible Vinemount member and the more resistant Reformatory Quarry member.

5.2 Soil Composition

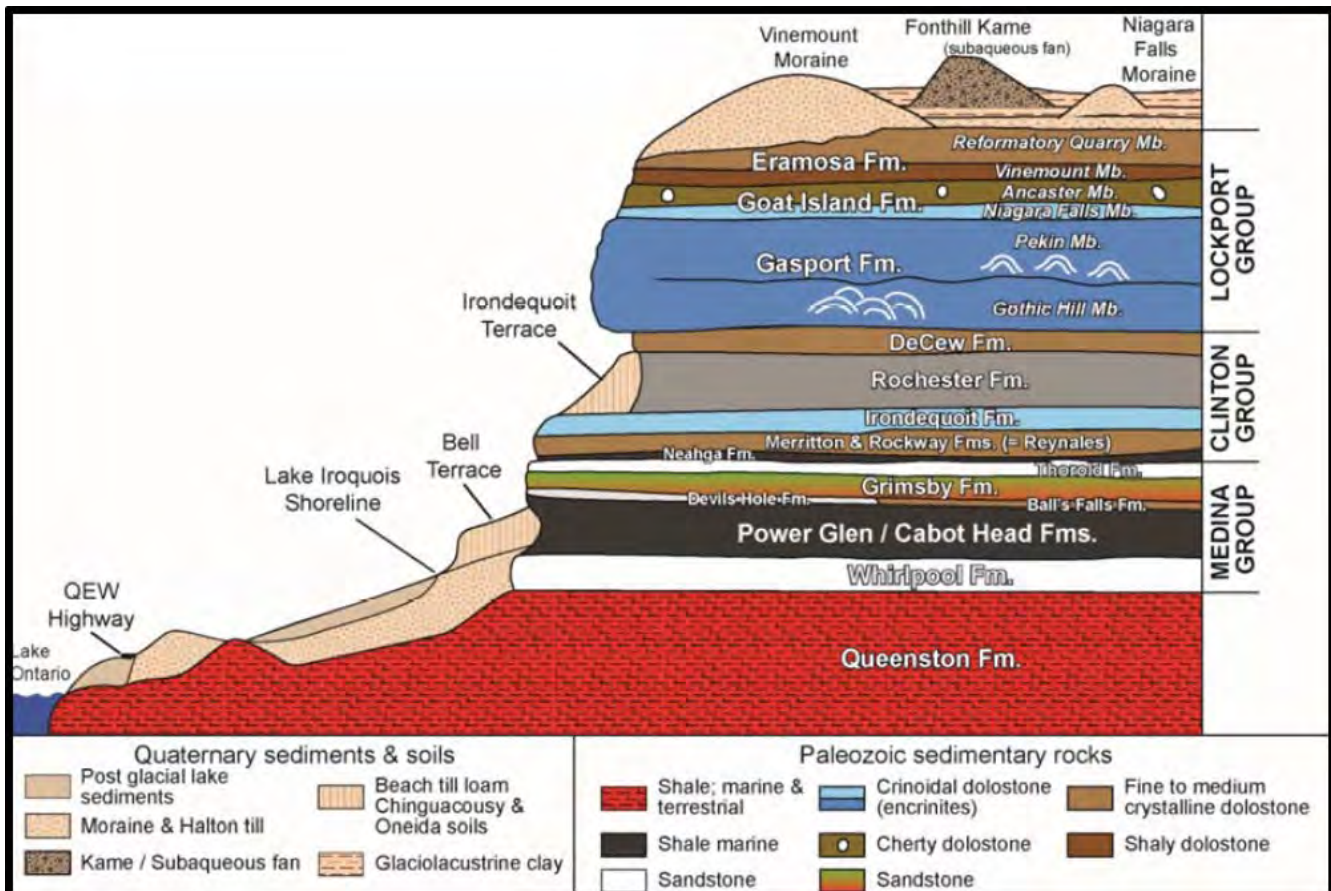
The investigation disclosed that beneath a topsoil veneer or road pavement, with a layer of earth fill in places, the site is underlain by silty clay, overlying dolomite and limestone bedrock. Soil types for all SCA properties are noted on Figure 8 Soil Composition.

Soil samples were analyzed by the engineering consultants for the BC-1 wetland project and the following results reported:

- **Topsoil:** The topsoil layer varied from 15cm to 340cm depth, dark brown in colour with appreciable amounts of roots and humus.
- **Earth Fill:** An earth fill layer was found beneath the pavement structure on First Road East. It consisted of silty clay with sand, gravel and occasional topsoil inclusions. The earth fill extends to a depth of 0.8m to 1.5m below the pavement level. If this fill is to be excavated and re-used on site as structural backfill it must be sorted free of any deleterious materials.

- **Silty Clay:** Silty clay was found in all borehole samples and deemed to be a native stratum. It is a glaciolacustrine deposit, laminated with silt and sand seams. Firm clay was found extending to depths of 0.6m to 0.8m from grade.
- **Bedrock:** Bedrock is encountered at a depth ranging from 0.6m to 5.5m from the ground surface. It is dolomite or limestone, a grey sedimentary rock of Amabel formation, of poor quality. It is difficult to excavate and contains rock fractures. Any excavation within 1m to 1.5m into bedrock will require a heavy-duty excavator equipped with a rock-ripper.

Figure 7. Conceptual Geological Section



Wetland Storage and Natural Channel Design Study, 2021, Waters Edge (from Brett & Brunton, 2018)

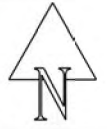
5.3 Hydrology and Surface Drainage

Drainage patterns in the study area have been heavily altered by the agricultural land use, but still hold true to the landscape. This study area is divided between two different subwatersheds of the Stoney Creek watershed. The moraine is split into two lobes which effects the drainage pattern. The main Saltfleet property where the artificial wetlands of BC-1 were created is located in the Battlefield Creek subwatershed while the rest of the properties are found in the Stoney Creek subwatershed.

FIGURE 8. SOIL COMPOSITION

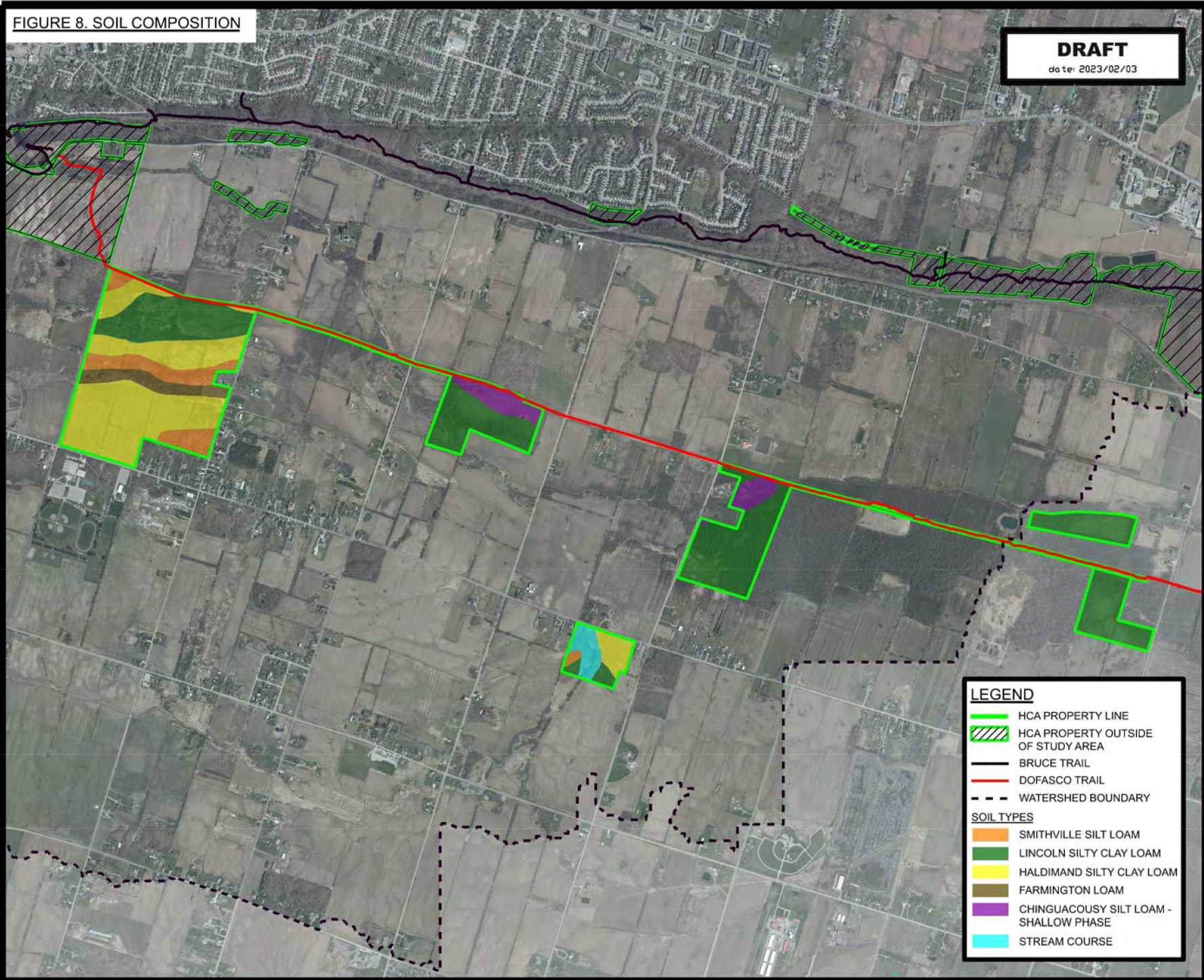
DRAFT

date: 2023/02/03








DATE: 2023/02/03

SOIL COMPOSITION



LEGEND

-  HCA PROPERTY LINE
-  HCA PROPERTY OUTSIDE OF STUDY AREA
-  BRUCE TRAIL
-  DOFASCO TRAIL
-  WATERSHED BOUNDARY

SOIL TYPES

-  SMITHVILLE SILT LOAM
-  LINCOLN SILTY CLAY LOAM
-  HALDIMAND SILTY CLAY LOAM
-  FARMINGTON LOAM
-  CHINGUACOUSY SILT LOAM - SHALLOW PHASE
-  STREAM COURSE



.1 Battlefield Creek

The Battlefield Creek headwaters come from the north-western edge of the southern moraine lobe and generally flow in a north-west direction, the Centennial Road cut in the escarpment. There are essentially three branches. the western most one follows Centennial Road. The central one flows northern into BC-1 where it intersects with some karst features, where the surface drainage flows disappear upstream of the Eramosa scarp and reappear at the base of it. The flow from these features are now captured in the southern cells of the BC-1 created wetlands while eastern flows first cross Green Mountain Road before turning west to cross Second Road East and are captured by the larger eastern cell of BC-1. There are some remaining small flows from the north side of the Dofasco trail that flow into the remaining natural swamp and marsh avoiding being captured by the created wetlands. The flows from the site then head west from the flowing through a large road culvert under First Road East. The central branch joins the east one at this point and the western one at Centennial Road before the combined Battlefield Creek flows over the Niagara Escarpment. Battlefield Creek joins Stoney Creek below the escarpment about 4.5 km downstream before Stoney Creek flows directly into Lake Ontario after about another 1.5 km.



.2 Stoney Creek

Stoney Creek has two main source branches, the first begins south of the Battlefield Creek headwaters along the southern side of the southern moraine lobe. It flows east and then turns north entering the gap between the lobes in the area of SC-8. The gap between the lobes is where the Provincially Significant Vinemount Swamp is located. This is where the second branch joins bringing with it the waters of the swamp just upstream of Taplestown woods. From here, Stoney Creek flows northwest through the lobe gap picking up a small amount of flow from the northern lobe before falling over the Niagara Escarpment at the Devil's Punchbowl. Stoney Creek below the escarpment flows north for about 4.5 km before being joined with Battlefield Creek. Stoney Creek flows directly into Lake Ontario after about another 1.5 km.

All the watercourses are intermittent or ephemeral, and have limited substrate sorting. Much of the length of the creeks has been channelized or exists as well-defined watercourse. For the purpose of the Aquatic inventory, they will be divided into 4 assessment areas BC-1, SC-8, Taplestown Woods, and Vinemount Swamp.

5.4 Biophysical Inventory Methodology

Biophysical inventories completed at Saltfleet Conservation Area consisted of Ecological Land Classification surveys completed in 2020 and 2021, noted in Table 7. Ecological Land Classification was completed across multiple properties in this Conservation Area and is shown on Map 1. in Appendix 1. Species lists are included in Appendix 6.

Table 7. Summary of Ecological Field Studies at Saltfleet Conservation Area Properties

Survey Type	Dates	
	Year	Day(s)
Floral Inventory	2019, 2021, 2022	July 9 and August 23, 2019, May, June 19 and Aug 23 2019, May 5, 2021, May 18 2022, Oct 8 2021, others concurrent with ELC surveys
Breeding Bird Surveys	2019, 2021, 2022	June 21 and July 9, 2019, June 19 and July 5 2019, June 2 and July 7 2021, June 3 and 19, 2022
Migratory bird surveys (BC-1 only)	2019	April 12, 29, May 10, 14, Sept 19, 24, Oct 4 and 8.
Waterfowl Surveys (Vinemount swamp only)	2022	March 10, 15, 22, 31 and April 7th
Frog Call Surveys	2019, 2021	June 19, 2019, April 18, May 15, June 19 2019, April 7, May 27, June 7, 2021
Ecological Land Classification (ELC)	2019, 2021, 2022	July 9, 2019, May 14 2019, May 5, Oct 7, Oct 8 2021, May 18, 28, Jul 29, Sep 2, Sep 9, Sep 15 2022
Bat Cavity Habitat Assessment and Acoustic monitoring (BC-1 and SC-8 only)	2019	May 15-16, May 29-June 26 July 9, June 19-17
Incidental wildlife survey	Recorded when encountered during all visits – 2019, 2021 and 2022	

5.5 Ecological Land Classification

The Ecological Land Classification (ELC) system for Ontario was used to describe the vegetation communities at Saltfleet Conservation Area properties. Two of the parcels, BC-1 and SC-8 were surveyed by an environmental consulting firm, Natural Resource Solutions (NRSI) in 2019. The remainder of the properties were surveyed by staff. These were conducted from 2021-2022. Details on the canopy, sub canopy, shrub and ground layers of each vegetation community were recorded. Vegetation community boundaries were determined using air photo analysis and further refined in the field.

5.6 Flora/Botanical Inventory

Botanical inventories were conducted as a part of the Ecological Land Classification surveys of the properties. Specific floristic inventories occurred in the spring of 2021 for spring ephemerals (early spring flowers) and the fall of 2022 to further identify asters and goldenrod species as they bloom late in the season. Species nomenclature is based on the Natural Heritage Information Centre (NHIC) Plant Species list (updated yearly). Species and community ranks are determined provincially by the Ministry of Natural Resources and Forestry Natural Heritage Information Centre Database (S-ranks) and locally via the Hamilton Natural Areas Inventory (Schwetz 2014). Inventories for BC-1 and SC-8 were conducted by NRSI and summarized in this document; see Appendix 6.

5.7 Fauna Inventory

Frog call surveys were conducted on BC-1 and SC-8 in 2019 and on all other properties in 2021. All surveys followed the Marsh Monitoring Program protocol. This includes three nights of surveys from April to June when temperatures at night are 5, 10 and 15 degrees, respectively.

.1 Bat Acoustic monitoring

Passive acoustic monitoring was completed for BC-1 and SC-8. This type of survey is used to identify bats that move past the monitors and may be using the properties. This section is directly from the NRSI report (2020).

Bat acoustic monitoring was completed at four locations within BC-1; the cultural savannah, cultural meadow, meadow marsh, and swamp habitats and at one location on SC-8, in the middle of the riparian corridor. The methodology is the same for both properties. Bat acoustic monitoring methodology followed the guidelines outlined within the MNRF Survey Protocol for Species at Risk Bats within Treed Habitats for Little Brown Myotis (*Myotis lucifugus*), Northern Myotis (*M. septentrionalis*) and Tri-Colored Bat (*Perimyotis subflavus*) (MNRF 2017) and is described in detail below. Microphones were placed along the edge of the habitat in candidate foraging areas to conceal the microphones from any bats to avoid recording inspection calls. Bat activity was monitored with the use of an omnidirectional SMM-U1 microphone and Song Meter SM4 acoustic recorder (Wildlife Acoustics Inc., Massachusetts, USA).

.1 Acoustic Monitoring Frequency and Timing

Passive acoustic monitoring was conducted between May 29 and June 26, 2019 for a total of 29 nights at all monitoring stations in BC -1 and from June 19 and July 17, 2019 in SC-8. Acoustic detectors were set to record bat passes for a total of 5 hours each night during the monitoring period, commencing at sunset. Upon review of weather conditions during the monitoring period, bat echolocation calls recorded on the 20 evenings with the most ideal weather conditions for bat activity (ambient temperature greater than 10°C, low wind and no precipitation) were selected for further analyses. As per MNRF (2017), at least 10 monitoring nights that align with the above weather conditions where no SAR bat activity is detected are required to confirm their absence from a given habitat

2 Acoustic Data Analysis

The acoustic recorders used for this study employ direct digital recording technology and are designed to collect records from the full spectrum of bat calls (15-120 kHz) for the entire duration of the monitoring period. This allows for a full analysis of activity in the vicinity of each acoustic monitoring station. Identification of call sequences to species level are typically possible with a quality ultrasound microphone (as used in this study) when recordings of bat echolocation calls are made in the open, the bat approaches close to the microphone, the bat produces echolocation calls typical for that species, and there are few things interfering with the passage of ultrasound from the bat to the microphone (wind, proximity to the ground, type and abundance of vegetation, etc.). However, this perfect scenario rarely exists. All of the above factors can influence the ability to identify a call sequence to the species level. In addition to these conditional factors, many of the sounds produced by a particular species of bat are also produced by other species (i.e. they have overlapping ranges of call characteristics). The degree of overlap in call characteristics varies by species. These factors must all be taken into consideration when acoustic bat monitoring is undertaken. Bat echolocation calls recorded during passive acoustic surveys were visualized with the software program SonoBat 4.2.2 for the north/northeastern US, Southern Ontario Region and identified to species with the SonoBat Auto-classifier. Once the required files were manually vetted, the auto-classification program provided an estimated likelihood of presence for each species, also known as a maximum likelihood estimate (MLE). An MLE value provides an indication of the strength of evidence for the presence of a species.

No specific surveys were conducted for other wildlife on the property. All wildlife encounters were incidental while conducting other aspects of field work. These surveys involved general coverage recording all species observations and signs (e.g. tracks/trails, scat, and burrows, dens, browse and vocalizations). Background data including older survey material was used to develop a list of butterflies, mammals and dragonflies that have been recorded by naturalists at SCA over the last 10 years. A summary of the findings can be found in Appendix 6.

5.8 Waterfowl, Migratory and Bird Breeding Surveys

Migratory bird surveys were conducted over eight (April - Oct) visits in order to record species that migrate through BC-1 throughout the spring and fall. Methods outlined in the Significant Wildlife Habitat Technical Guide (MNR 2012) were used by NRSI. Waterfowl surveys were conducted in flooded fields associated with the Vinemount Swamp. These were conducted weekly between March and April 2022, by HCA staff. Breeding bird surveys were conducted over six visits between 2020 and 2022 following the Ontario Breeding Bird Atlas (Cadman 2010) methodology. These occurred on all properties and were completed for BC-1 and SC-8 by NRSI and at all other properties by HCA staff.

5.9 Ecological Land Classification Results

Field surveys occurred over 11 visits between 2019-2022. This included all properties

throughout the Saltfleet Conservation Area. BC-1 and SC-8 surveys were conducted by NRSI and are summarized in this document. The subject properties were delineated into 28 vegetation communities (BC-1-9, SC-8 -4, Tapleystown - 3, Vinemount - 12). Details on community classifications can be found in Appendix 1 and on Maps 1 and 2.

5.10 Flora/Botanical Inventory Results

Surveys were completed for multiple parcels within the SCA. These surveys were conducted both by HCA staff and NRSI (BC-1 and SC-8 exclusively). The Hamilton NAI (HCA 2014) indicates that there are 1496 species of plants in the Hamilton-Wentworth jurisdiction. Percent of regional flora for each area is presented below. The results for various parcels are detailed in Table 8. below.

Table 8. Floristic Quality Index

	BC-1	SC-8	Tapleystown Woods	Vinemount Swamp
Native Plant species	97	100	83	116
Non-native plant species	53	44	16	32
Total plants recorded	150	56	99	148
% of regional flora	10	7	7	10
Mean CC	3.50	2.15	4.43	4.03
Floristic Quality Assessment	34.42	16.06	40.31	43.46
Value assessment (Quality)	Moderate	Low	Good	Good

The Floristic Quality Index (FQI) and the Native Mean Coefficient of Conservatism (CC) have been calculated for each property. The CC is a measure of the species specificity of habitat requirements, with a coefficient of 0 indicating a plant tolerant of a wide range of conditions and 10 indicating a plant that has the most specific habitat requirements. FQI is a measure of vegetation quality and is based on both the habitat fidelity of each species and species richness. The FQI for SC-8 is low, likely due to its agricultural nature and limited area of native vegetation. Tapleystown Woods and Vinemount Swamp have higher FQI's due to their diversity of habitat types and large size.

5.11 Fauna Inventory Results

.1 Migratory Waterfowl Surveys

There are a number of flooded agricultural fields associated with the HCA properties on the east mountain. Two of the largest flooded fields, one on the east side of Eighth Road and the other on the west side of Fifth Road are not owned by HCA. On the west side of Eighth Road and south of the Vinemount Swamp is a small, flooded field. This field had water from mid-March 2022 – end of May 2022. Species found during waterfowl surveys west of the Eighth Road include Canada Geese, Tundra swan, Mallards, Ring-billed Gulls, American Wigeons, American Black Ducks and Wood Ducks.

.2 Breeding Bird and Migratory Songbird Surveys for BC-1

These surveys were conducted by NRSI at BC-1 in 2019. The data within the report is not segregated into migratory and breeding species. Therefore, these sections have been kept together for reporting purposes. In total 105 bird species were recorded between migrating and breeding birds. For the migratory bird species more than 35 species of birds were identified in portions of the BC-1 property. These included 19 Wood Warblers, 9 Emberizid Sparrows, 7 thrushes, 5 woodpeckers, 5 Flycatchers and 4 Vireos. There were more than 10 migratory birds noted at each of the 8 targeted surveys and greater than 200 birds per day. This type of survey was not conducted at the other properties within this Conservation Area. The migratory and breeding bird surveys resulted in 105 species of birds recorded on the property. As for breeding bird surveys on the property the following paragraph was taken from the NRSI report (2020).

A number of locally rare bird species (HCA 2014) were observed during both the migration and breeding seasons; Yellow-billed Cuckoo, Common Nighthawk, Wilsons Snipe, Yellow-bellied Sapsucker, Merlin, Blue-headed Vireo, Common Raven, Carolina Wren, Golden-crowned Kinglet, Magnolia Warbler, Blackburnian Warbler, Black-throated Blue Warbler, Yellow-rumped Warbler, Black-throated Green Warbler. During the migration surveys, an exceptional diversity of species, including most warbler observations, was noted from the cultural savannah and swamp feature along the mini escarpment. No other background data is available for this property.

.3 Breeding Bird Surveys

Breeding bird surveys on the other properties were conducted in the spring and summer of 2019, 2021 and 2022. The number of species identified on the different parcels and species of note are discussed below.

.1 SC-8

Thirty-one species of birds were identified from SC-8 during breeding bird surveys. From the NRSI report: A number of locally significant bird species (HCA 2014) were observed during the breeding season, Species which are uncommon in Hamilton were observed including Brown Thrasher– a pair (probable breeding evidence), and Northern Mockingbird – perched on hydro wires along Green Mountain Road in suitable habitat (possible breeding evidence). No other background data is available for this property.

.2 Tapleystown Woods

Breeding bird surveys identified 27 species of birds including the Bobolink, Eastern Wood-Pewee, and Wood Thrush, all of which are at risk provincially and federally. Other notable species include the Yellow-Billed Cuckoo and Brown Thrasher which are uncommon in the City of Hamilton. Incidental sightings by staff identified an additional 3 species including Great Horned Owl, Eastern Screech Owl (uncommon to the area) and Red-Headed Woodpecker on migration, which is endangered provincially and federally.

Data was also collected from the Natural Areas Inventory and eBird as historical data. This data has identified 14 additional species in the area including the Great Blue Heron, flying

overhead, Red-Bellied woodpecker, Red-Tailed Hawk, Scarlet Tanager and Vesper Sparrow, all of which are uncommon to the City of Hamilton.

.3 Vinemount Swamp

Breeding bird surveys identified 20 species of birds including the Barn Swallow, which is threatened provincially and federally. This species was noted foraging above the meadow marsh on the southern portion of the property east of Fifth Road and south of the Dofasco Trail.

Historical data from the Natural Areas Inventory as well as incidental sightings by staff identified an additional 34 species of birds in this area. This includes the Eastern Wood-Pewee and Wood Thrush, provincially special concern and threatened, respectively.

.4 Butterflies and Dragonflies

No dedicated surveys were conducted for these two taxa. There is background information from the NAI and there are also surveys done by NRSI for SC-8 and BC-1.

Tapleystown Woods had 16 butterflies and no dragonflies were observed on this property. The Vinemount Swamp group of properties had 4 dragonflies and 26 butterflies. The surveys on BC-1 counted 5 dragonflies and 14 butterflies and finally SC-8 recorded one dragonfly and four butterflies. Monarch butterflies a federally endangered species were found on BC-1, SC-8 and Vinemount. These were mainly observed nectaring along open trails and within the wet meadows in Vinemount. The Wild Indigo Duskywing (BC-1) and Bronze Copper (Vinemount) are locally uncommon.



Twelve-Spotted Skimmer

.5 Mammals

All incidental wildlife encounters were recorded while conducting other aspects of field work. Mammal sightings were also recorded during historical surveys conducted for the Natural Areas Inventory and by NRSI prior to wetland construction. These surveys involved general coverage recording all species observations and signs (e.g. tracks/trails, scat, burrows, dens, browse, and vocalizations).

.1 BC-1

Surveys by NRSI in 2019 identified 14 species of mammals from the property. Details on bat surveys that occurred at BC-1 are detailed below, directly from the NRSI Report:

“Four bat species were documented as present within the subject property during passive acoustic monitoring. All of the confirmed species are relatively common throughout Ontario. In addition to the confirmed species, bat pass sequences were

also identified to the Myotis species grouping, which includes Little Brown Myotis, Eastern Small-footed Myotis (*M. leibii*) and Northern Myotis, as well as the 40 kHz species grouping which includes the Myotis species, Tricolored Bat and Eastern Red Bat (*Lasiurus borealis*). All Myotis species which occur in Ontario and the Tri-colored Bat are listed as Species at Risk.”

“A total of 6,775 bat pass sequences were recorded throughout the acoustic monitoring period that were of high enough quality that they could be classified to either the species level or a species grouping. The majority of these bat pass sequences that were classified to the species level were identified as Big Brown Bat (*Eptesicus fuscus*) (35.92%). Several sequences were classified to Hoary Bat (*Lasiurus cinereus*) (11.66%) and Silver-haired Bat (*Lasionycteris noctivagans*) (7.82%). A small proportion of calls were classified to Eastern Red Bat (*Lasiurus borealis*) (2.37%)”.

.2 SC-8

Surveys by NRSI in 2019 identified 12 species of mammals from the property. Details on bat surveys that occurred at SC-8 are detailed below, directly from the NRSI Report:

“Four bat species were documented as present during passive acoustic monitoring conducted within the subject property. All of these species are considered common throughout Ontario”.

“A total of 868 bat pass sequences were recorded throughout the acoustic monitoring period that were of high enough quality that they could be classified to either the species level or a species grouping. The majority of these bat pass sequences that were classified to the species level were identified as Big Brown Bat (*Eptesicus fuscus*) (52.65%). Several sequences were classified to Eastern Red Bat (*Lasiurus borealis*) (6.34%), Hoary Bat (*L. cinereus*) (4.49%) and Silver-haired Bat (*Lasionycteris noctivagans*) (4.03%)”.

Species at risk bats and significant wildlife habitat related to bats are discussed in Section 5.14

.3 Tapleystown woods and Vinemount

Between these two areas six species of mammals were identified including White-tailed deer, Gray squirrel, Virginia opossum, Coyote, Eastern cottontail, Northern racoon. These species are typical of these types of properties, with meadows, forests and houses. These species are all common in Ontario and in the City of Hamilton. Bat surveys were not conducted at these properties.

.6 Herpetofauna

.1 BC-1

Surveys for this property were conducted by NRSI. Their report states that:

“NRSI field investigations confirmed the presence of 8 species of reptiles and amphibians within the subject property. No Species at Risk or Species of Conservation

Concern were documented from the site. None of the reptile and amphibian species observed are considered locally rare (HCA 2014). Calling anuran surveys documented 5 species of anurans (frogs and toads) within the subject property. Northern Leopard Frog (*Lithobates pipiens*) was observed incidentally, on several occasions, during other surveys.”

.2 SC-8

Surveys for this property were conducted by NRSI. Their report states that:

“NRSI field investigations confirmed the presence of 2 species of anuran; Gray treefrog (*Hyla versicolor*) and Green Frog (*Lithobates clamitans melanota*) within the subject property. Neither species is considered a Species at Risk or Species of Conservation Concern or locally significant (HCA 2014). Calling anuran surveys commenced in June and therefore survey data for the months of April and May was not collected. June surveys documented 2 species of anurans within the subject property.”

.3 Tapleystown Woods

One frog call survey location was completed at Tapleystown Woods. This was focused on a small woodland pool along the southeastern edge of this property. Over the course of three surveys only Western Chorus frogs were detected from this woodland pond.

.4 Vinemount

Roadside surveys along Fifth and Eighth Road East were conducted adjacent to property owned by HCA in the Vinemount Swamp. A full chorus of Western Chorus frogs was heard calling from the road side ditches along Fifth and Eighth Road East. This species was also heard calling within the meadow marsh (MAMM 2-4) community on the southern portion of this property. Pickerel frogs were also heard in the early spring in the ditches along Eighth Road East. American toads were also heard further onto the properties within the existing deciduous swamps and thicket swamps. Adult snapping turtles were also found in the deciduous swamps of the properties within the Vinemount Swamp.

5.12 Aquatic Inventory

.1 BC-1

BC-1 contains two intermittent branches of Battlefield Creek one comes in from the south draining through karst features above the Eramosa Scarp and then out letting at its base. Below the scarp the watercourse was direct fish habitat before the southern cells of the created wetland were installed. The water control structure will act as a barrier to fish movement. The new feature is being monitored and if HCA Ecologists determine it is ecologically valid and the ponds will support native fish populations stocking could be explored at a later date.



Brown Bullhead

The second branch enters the BC-1 property from the east crossing Second Rd. East below the Eramosa Scarp. Here it enters the large eastern wetland cell. The watercourse is direct fish habitat, but the wetland control structure is a barrier to fish movement. The remaining watercourse branch as well as the new deeper cell feature will be monitored to understand how these changes may affect the fish populations. If ecological concerns are noted solutions will be investigated. The current fishery is indicative of a warmwater environment which should be maintained on the property by the created wetland feature and will likely be enhanced. The proposed monitoring will help provide this information as time progresses. See Table 9 for fish recorded by NRSI, as part of the BC-1 Wetland Design project.

Table 9. Fish Recorded by NRSI. BC-1

Common Name	Scientific Name
Pumpkinseed	<i>Lepomis gibbosus</i>
Brook Stickleback	<i>Culaea inconstans</i>
Fathead Minnow	<i>Pimephales promelas</i>
Brown Bullhead	<i>Ameiurus nebulosus</i>

.2 SC-8

SC-8 contains the mainstem of Stoney Creek and based on the fish species present is a coolwater stream. However, they also represent tolerant to intermediately tolerant species likely reflecting the intermittent nature of the creeks flows. The channel is a narrow corridor between two agricultural fields at the time of writing this, however. In the near future this will be the site of the next wetland project. The design maintains the mainstem corridor and the control structure is being designed in such a way fish passage should still occur through it. Several deeper floodplain pools are being created in a widened floodplain environment. Depending on the realized drawdown time these future conditions should not alter the fish community but may enhance them both with the additional floodplain access and improved flow conditions downstream. See Table 10 for record of fish collected by NRSI at SC-8, as part of the wetland design project.

Table 10. Fish recorded by NRSI, SC-8

Common Name	Scientific Name
Pumpkinseed	<i>Lepomis gibbosus</i>
Brook Stickleback	<i>Culaea inconstans</i>
Fathead Minnow	<i>Pimephales promelas</i>
Central Mudminnow	<i>Umbra lima</i>
Northern Pearl Dace	<i>Margariscus nachtriebi</i>
Northern Redbelly Dace	<i>Chrosomus eos</i>

.3 Vinemount Swamp

The Vinemount Swamp represents the poorly drained lowlands between the two moraine features. Its drainage is enhanced by the channels dug through it which represent the

watercourses in this area. This watercourse flows west out of the swamp, outletting into the main channel of Stoney Creek just east of Tapleystown Road. The fish species present indicate it is a coolwater environment but also reflect the intermittent nature of the swamp as the species represent “tolerant” to “intermediately tolerant” species.

The Aquatic Resource Monitoring Plan monitors the Vinemount Swamp branch of Stoney Creek. See Table 11 for fish recorded.

Table 11. Fish Recorded Vinemount Swamp

Common Name	Scientific Name
Brook Stickleback	<i>Culaea inconstans</i>
Central Mudminnow	<i>Umbra lima</i>

.4 Tapleystown Woods

Stoney Creek bisects the south west corner of this HCA property. Like many of the watercourses in the area, it is an artificial channel cut through the swamp forest on site. No fish sampling was conducted on this property but the fishery is expected to remain the same as is found upstream at SC-8 and Vinemount Swamp. An intermittent coolwater stream with a tolerant to intermediately tolerant fishery. See Table 12.

Table 12. Records for the Mainstem of Stoney Creek

Common Name	Scientific Name
Pumpkinseed	<i>Lepomis gibbosus</i>
Brook Stickleback	<i>Culaea inconstans</i>
Fathead Minnow	<i>Pimephales promelas</i>
Creek Chub	<i>Semotilus atromaculatus</i>
Central Mudminnow	<i>Umbra lima</i>
Northern Pearl Dace	<i>Margariscus nachtriebi</i>
Northern Redbelly Dace	<i>Chrosomus eos</i>

5.13 Significant Ecological Features

.1 Significant Woodlands

The following properties or portion of properties are considered significant woodland by the City of Hamilton:

- Northwest corner of BC-1 (SWDM 2-2)
- All of Tapleystown Woods
- Central portion of Vinemount Swamp off of Fifth Road East
- The majority of parcels to the west of Eighth Road East in the Vinemount Swamp

Significant woodlands for the City of Hamilton mean an area which is ecologically important in terms of features (species composition, age of trees and stand history) and function (contributes to the broader landscape because of its location, size or the amount of forest cover in the planning area) (City of Hamilton, 2019).

.2 Environmentally Sensitive Area

There is one Environmentally Significant Area within the properties in the Master Plan. The Vinemount Swamp properties are part of STCK-77 – Vinemount South Swamp and this ESA covers the majority of properties owned by HCA between Fifth and Eighth Road East.

This ESA was designated because it meets two of the 2003 ESA criteria including:

1. Significant Ecological Function
 - the area contains interior forest habitat (100-200m from forest edge)
 - the area provides habitat for significant species
 - the area provides migratory stopover habitat and a colonial nesting site
 - the area contains rare biotic communities
2. Significant Hydrological Function
 - the large headwaters wetland is a groundwater recharge area and helps to moderate surface water flow

The ESA area is protected within the Rural Official Plan for the City of Hamilton. No new development or site alterations are permitted within or adjacent to ESA's, unless it can be shown, through an Environmental Impact Statement (EIS) that there will be no negative impacts on the ecological features or functions of the ESA.

.3 Provincially Significant Wetland

The Vinemount South Swamp forest is the biggest natural forest area south of the Escarpment in the Hamilton area. It also serves as a stopover for many species of migratory waterfowl. The Vinemount Swamp is a headwaters swamp, it serves an important purpose in regulating the stream flow in Forty Mile Creek and Stoney Creek.

5.14 Biophysical Inventory – Analysis

1 Species at Risk and Locally Rare Species

.1 Significant Flora

Of the plant species recorded on the subject lands through the 2019, 2020 and 2021 field surveys, six plant species were found to be locally uncommon, one locally rare and one provincially rare. The Butternut is mainly found along the unopened road allowance on the south side of Tapleytown Woods. These are presented in Table 13. below. The majority of the other uncommon and rare species are found within the wood and field sections of these properties.

Table 13. Significant Flora

	BC-1	SC-8	Tapleystown Woods	Vinemount swamp
Provincially rare				
Butternut			x	
Locally rare				
Bristly Black Currant			x	
Locally uncommon				
Grays Sedge	x		x	x
Dropping Sedge				x
Maple-leaved Goosefoot		x	x	
Hairy goldenrod			x	
False Mermaidweed	x		x	
Woolly Sedge	x			
Total	3	1	6	2

Of particular interest is False Mermaidweed. This plant species is only visible in early spring when it can form a carpet of plants along the forest floor. It has a coefficient of conservatism of 10 which means it has a lower tolerance to environmental degradation. As it is naturally restricted to undisturbed, remnant habitats, it indicates that the two forest patches it was found in, the south portion of the Tapleystown Woods and the south-east forest at the BC-1 property, are likely very old and have had little disturbance in the past.

.2 Significant Fauna

The following six species were recorded at various parcels of the Conservation Area and are at risk either federally (SARA) or provincially (ESA). These species were recorded at Saltfleet at different life stages from migration to breeding as indicated in Table 14.



Table 14. Federal and Provincial Species at Risk

Common name	Scientific name	SARA status (Schedule 1)	ESA status	BC-1	SC-8	Tapleytown	Vinemount
Barn Swallow (B)	<i>Hirundo rustica</i>	THR	THR	x	x		
Bobolink (B)	<i>Dolichonyx oryzivorus</i>	THR	THR	x		x	
Common Nighthawk (M)	<i>Chordeiles minor</i>	THR	SC	x			
Eastern Meadowlark (B)	<i>Sturnella magna</i>	THR	THR	x			
Red-headed Woodpecker (M)	<i>Melanerpes erythrocephalus</i>	END	END			x	
Wood Thrush (B)	<i>Hylocichla mustelina</i>	THR	SC	x		x	x
Myotis Bats (B)	<i>Myotis Sp</i>	END	END	x	x		

The Barn Swallow (2020) and Common Nighthawk (2018) have been reassessed recently by the federal Committee on the Status of Endangered Wildlife in Canada (COSEWIC) to Special Concern. Neither status has been changed on Schedule 1 of SARA as of the writing of this Master Plan so they will be treated as SAR in this document. At SC-8, Barn Swallow (*Hirundo rustica*) was observed foraging above the watercourse (marsh and swamp thicket areas) and over the fields on several surveys in June and July. As many as 6 birds were present at one time. At BC-1 this species was noted foraging over the marsh areas and fallow agricultural fields during the bird surveys. No appropriate nesting locations were noted on either SC-8 or BC-1 and these birds are likely nesting nearby. Bobolink were noted in the agricultural field adjacent to the Tapleytown woods during the breeding bird surveys. At BC-1 this species was noted as a fly over, but suitable habitat is present in the fallow fields on the property. Eastern Meadowlark was recorded at BC-1 in ebird and suitable habitat is present on site. Common Nighthawk was noted at BC-1 on May 15, 2019. It was observed foraging and performing aerial displays. This date is within the migration period for this species in the Hamilton area, so this could have been a bird on migration. But Common Nighthawk is a cryptic, nocturnal species and observation of breeding evidence is difficult to confirm and this bird was noted in suitable habitat. Therefore, this species is considered an unconfirmed breeder within the thickets and cultural savanna. A Red-headed woodpecker was seen during migration in the spring at Tapleytown woods within the Sugar Maple forest. Wood thrush was noted on all properties except SC-8. It was heard during breeding bird surveys within the deciduous forests and swamps on these properties. The surveys by NRSI at both SC-8 and BC-1 identified the potential for species at risk bats to be using BC-1 for foraging and breeding and SC-8 for foraging. Due to the nature of acoustic monitoring, it is difficult to determine exactly which Myotis species is using these properties. They are therefore just listed as Myotis sp. in the chart above.

Threatened and endangered species habitat is protected under the Endangered Species Act (provincially) and the Species at Risk Act (federally). Permits may be required for

development within the habitat for threatened and endangered species.

There were also a large number of locally rare and uncommon species recorded during field surveys and found in the background research. BC-1 had the largest majority of locally uncommon 42 species, SC-8 had 3, Tapleystown 13, Vinemount 15. These include birds and butterflies and are mostly concentrated within the forest, swamps, and thicket sections of these properties. See Table 15.

Table 15. Locally Rare and Uncommon Species

Common Name	Scientific name	City of Hamilton Status	BC-1	SC-8	Tapleystown	Vinemount
Blackburnian Warbler	<i>Setophaga fusca</i>	Rare	x			
Black-throated Green Warbler	<i>Setophaga virens</i>	Rare	x			
Blue-headed Vireo	<i>Vireo solitarius</i>	Rare	x			
Carolina Wren	<i>Thryothorus ludovicianus</i>	Rare	x			
Common Nighthawk	<i>Chordeiles minor</i>	Rare	x			
Common Raven	<i>Corvus corax</i>	Rare	x			
Golden-crowned Kinglet	<i>Regulus satrapa</i>	Rare	x			
Magnolia Warbler	<i>Setophaga magnolia</i>	Rare	x			
Merlin	<i>Falco columbarius</i>	Rare	x			
Northern Pintail	<i>Anas acuta</i>	Rare			x	
Red-headed Woodpecker	<i>Melanerpes erythrocephalus</i>	Rare			x	
Yellow-bellied Sapsucker	<i>Sphyrapicus varius</i>	Rare	x			
Yellow-billed Cuckoo	<i>Coccyzus americanus</i>	Rare	x		x	
Yellow-rumped Warbler	<i>Setophaga coronata</i>	Rare	x			
Alder Flycatcher	<i>Empidonax alnorum</i>	Uncommon				x
American Kestrel	<i>Falco sparverius</i>	Uncommon	x			
American Redstart	<i>Setophaga ruticilla</i>	Uncommon	x			x
Belted Kingfisher	<i>Megaceryle alcyon</i>	Uncommon	x			
Black-and-white Warbler	<i>Mniotilta varia</i>	Uncommon	x			
Black-billed Cuckoo	<i>Coccyzus erythrophthalmus</i>	Uncommon	x			
Blue-gray Gnatcatcher	<i>Poliophtila caerulea</i>	Uncommon	x			

Common Name	Scientific name	City of Hamilton Status	BC-1	SC-8	Tapleytown	Vinemount
Bobolink	<i>Dolichonyx oryzivorus</i>	Uncommon	x		x	
Bronze Copper	<i>Lycaena hyllus</i>	Uncommon				x
Brown Creeper	<i>Certhia americana</i>	Uncommon	x			
Brown Thrasher	<i>Corvus brachyrhynchos</i>	Uncommon	x	x	x	x
Cooper's Hawk	<i>Accipiter cooperii</i>	Uncommon	x			
Eastern Bluebird	<i>Sialia sialis</i>	Uncommon	x			
Eastern Meadowlark	<i>Sturnella magna</i>	Uncommon	x			
Eastern Phoebe	<i>Sayornis phoebe</i>	Uncommon	x			x
Eastern Screech-Owl	<i>Megascops asio</i>	Uncommon			x	
Eastern Towhee	<i>Pipilo erythrophthalmus</i>	Uncommon	x			
Great Blue Heron	<i>Ardea herodias</i>	Uncommon	x		x	x
Hairy Woodpecker	<i>Dryobates villosus</i>	Uncommon	x			x
Herring Gull	<i>Larus argentatus</i>	Uncommon	x	x		
Marsh Wren	<i>Cistothorus palustris</i>	Uncommon				x
Nashville Warbler	<i>Oreothlypis ruficapilla</i>	Uncommon	x			
Northern Mockingbird	<i>Mimus polyglottos</i>	Uncommon	x	x		
Pileated Woodpecker	<i>Dryocopus pileatus</i>	Uncommon	x			
Red-bellied Woodpecker	<i>Melanerpes carolinus</i>	Uncommon	x		x	x
Red-breasted Nuthatch	<i>Sitta canadensis</i>	Uncommon	x			
Red-tailed Hawk	<i>Buteo jamaicensis</i>	Uncommon	x		x	x
Scarlet Tanager	<i>Piranga olivacea</i>	Uncommon			x	
Sora	<i>Porzana carolina</i>	Uncommon				x
Turkey Vulture	<i>Cathartes aura</i>	Uncommon	x			x
Vesper Sparrow	<i>Pooecetes gramineus</i>	Uncommon	x		x	x
White-throated Sparrow	<i>Zonotrichia albicollis</i>	Uncommon	x			x
Wild Indigo Duskywing	<i>Erynnis baptisiae</i>	uncommon	x			
Winter Wren	<i>Troglodytes hiemalis</i>	Uncommon	x			
Wood Duck	<i>Aix sponsa</i>	Uncommon	x		x	
Wood Thrush	<i>Hylocichla mustelina</i>	Uncommon	x		x	x

.2 Significant Wildlife Habitat

The Significant Wildlife Habitat Technical manual (Ontario 2000) along with the Ecoregional criteria tables for Ecoregion 7E (OMNR 2015) were used to determine and define significant wildlife habitat (SWH) on the SCA properties. Significant wildlife habitat includes broad categories of habitats for flora and fauna. SWH has been identified under the provincial policy statement for Ontario. No new development is allowed within identified portions of significant wildlife habitat unless there will be no negative impact to the form and function of this habitat type. The broad categories for significant wildlife habitat include seasonal concentration areas of animals, rare vegetation communities or specialized habitat for wildlife, habitats for species of conservation concern and animal movement corridors.

.1 Seasonal Concentration Areas of Animals

Seasonal concentration areas of animals are areas where wildlife species occur annually in aggregations (groups) at certain times of the year (Ontario 2015). This can include single species concentrations or aggregations of multiple species.

.1 Land bird Migratory Stopover Areas

These are areas with woodlots or forests within 5 km of either Lake Ontario or Lake Erie that migratory birds, especially song birds, use as rest stops before or after crossing the great lakes during migration. Land Bird Migration should be studied in woodlots 2-5 Ha in size where woodlots are rare in the area of shoreline (Ontario 2015). Studies are needed to confirm the use of the habitat by > 200 birds/day and with > 35 species with at least 10 bird species recorded on at least 5 different survey dates (Ontario 2015). Surveys by NRSI found:

“well over the 35 species required for this SWH type including 19 Wood Warblers, 9 Emberizid Sparrows, 7 Thrushes, 5 Woodpeckers, 5 Flycatchers and 4 Vireos. All 8 targeted surveys documented greater than 10 migratory species and numbers greater than 200 birds per day. Surveyors noted that bird diversity was very high within the cultural savannah and swamp located along the karst formation. It is inferred that the combination of upland and wetland habitat at this groundwater seepage location may result in higher numbers of insects during bird migration and provides a diversity of habitat which is desirable for migratory birds.”

Migratory bird surveys were not conducted on the other properties within this Master plan.

2. Bat Maternity Colonies

NRSI completed acoustic monitoring to survey for bat species at BC-1. From the NRSI report:

“Big Brown Bat and Silver-haired Bat were detected in relatively high numbers at all monitoring stations during every night of the monitoring period. The majority of these recordings were documented during the first and second monitoring hours, indicating that these species are potentially using woodlands throughout the subject property for roosting habitat, including for maternity roost colonies, or at the very least foraging

shortly after leaving nearby roosts. Big Brown Bats primarily form maternity colonies in buildings and other man-made structures but will also roost in tree cavities, although less frequently (Agosta 2002, Gerson 1984). Therefore, given the presence of several farm houses and barn structures in the area, this species is likely not using the woodlands as maternity roost colony habitat. Silver-haired Bats are solitary or may form small maternity colonies under loose bark and in cavities of trees and snags (van Zyll de Jong 1985). It is likely that Silver-haired Bat are using the treed features within the subject property for roosting and potentially as maternity colony roost habitat. Sites are considered SWH if greater than 10 Big Brown Bats and/or greater than 5 female Silver-haired Bats are using the site as maternity roost habitat. Based on the results of the acoustic monitoring, all SWDM and FODM vegetation communities within the subject property are considered Candidate Bat Maternity Colony SWH. Targeted exit surveys at potential roost trees within the woodlands would be required to confirm the presence of this SWH type within BC-1. The candidate bat roost tree(s) which appear to be within the cultural savannah (SVD) associated with the karst ridge Swamp (SWDM) features in the northern portion of the property were also identified as candidate bat roost habitat.

Bat acoustic surveys were also conducted at SC-8, but no SWH maternity colonies were found. These surveys were not conducted at Tapleystown Woods or Vinemount.

.3 Reptile Hibernaculum

This is a difficult type of significant wildlife habitat to survey due to the cryptic nature of snakes. From the NRSI report for BC-1:

“The observation of 3 snake species in the vicinity of the old residence and karst feature during the emergence period suggests that SWH for snake hibernacula may be present. Observations of snake diversity and numbers which were made by NRSI biologists approach the defining criteria for SWH and given the difficulty in surveying steep portions of the karst slope, this report assumes that a hibernacula is present. This feature may exist within one of the field stone foundations, or within rock crevices along the slope. The potential snake hibernacula is very likely located along the karst slope or in the vicinity of the old residence and out-building foundations accessed from First Road East. There were no indications of potential habitat within the low-lying northern portion of the site.

No Rocky outcrops or karst features were noted on the other properties.

4. Waterfowl Stopover and Staging area (Terrestrial)

Waterfowl stopover surveys were completed between March and April 2022. Sheeting water on agricultural fields is present in close proximity to the east and west extent of Vinemount. The agricultural fields to the west of Fifty Road and those to the east of 8th concession both had aggregations of Tundra swans, American Black Duck, Blue-winged teal, Green-winged teal, Northern Pintail, and Northern Shoveler. On some survey dates there were greater than 100 birds of these and other species using these fields. Although not on the Vinemount property, the buffer prescribed in the SWH Criterion Tables would

extend onto the property as it is 100-300 m from the edge of the agricultural field.

.2 Specialized Habitats of Wildlife

This is a community or diversity-based category as many wildlife require large areas of suitable habitat for successful breeding. The largest and least fragmented habitats within the planning area will support the most significant wildlife populations.

1. Seeps and Springs

These are areas where groundwater comes to the surface and are often found within forested areas. The criteria include the presence of 2 or more seeps or springs. There are numerous seepage areas recorded at BC-1. Surveys by NRSI in April and May noted water running out of karst features at the base of the small escarpment through the property. Evidence of use by Wild Turkey and White-tailed deer in the winter would confirm this as SWH, despite a lack of indicator plant species.

.3 Habitat for Species of Conservation Concern

Habitat for species of conservation concern includes wildlife that are listed provincially as species concern or are rare and declining.

.1 Shrub/Early Successional Bird Breeding Habitat

BC-1 contains multiple areas of thicket and cultural savanna. The breeding bird surveys documented the indicator species, Brown Thrasher and all four of the indicator species, Field Sparrow, Black-billed Cuckoo, Eastern Towhee and Willow Flycatcher. Thicket areas and the savanna should be maintained for these species.

.4 Special Concern and Wildlife Species

Table 16 provides a list of the four species located within the various properties that are of Conservation Concern. This list includes migratory species such as the Rusty blackbird and Snapping turtles in suitable nesting habitat. Eastern Wood Pewee was noted in several locations within the forested section of the properties while the Monarch was seen in open fields, marches and canopy gaps of small forest openings.

Table 16. Species of Conservation Concern

Common Name	Scientific name	SARA status (Schedule 1)	ESA status	BC-1	SC-8	Tapleytown	Vinemount
Eastern Wood-Pewee	<i>Contopus virens</i>	SC	SC	x		x	x
Monarch	<i>Danaus plexippus</i>	SC	SC	x	x		x
Rusty Blackbird	<i>Euphagus carolinus</i>	SC	SC	x			
Snapping turtle	<i>Chelydra serpentina</i>	SC	SC				x

.5 Animal Movement Corridors

These are generally linear features that are used by wildlife to move from one habitat to another. Ensuring they are maintained on the landscape is important to ensure genetic diversity in populations, to allow for seasonal migration and for wildlife to move in their home ranges from feeding to cover areas.

.1 Amphibian movement corridors

NRSI identified possible amphibian movement corridor on SC-8. Their report states that:

“An assessment of air photography in the vicinity of the subject property indicates that the corridor of natural vegetation may play an important role in wildlife movement through the headwaters of Stoney Creek and toward the Vinemount Swamp PSW to the northeast. Lands to the south of Tapleystown are largely agricultural and are limited in hedgerows, watercourses and forest parcels that would allow for a natural corridor connecting with Twenty Mile Creek which is approximately 5 km south of the property.” This corridor should be maintained as the site is developed into a wetland.

5.15 Managed Forest

A Managed Forest Plan was completed for HCA properties owned within the watershed in 2018. This is a 20-year plan that covers 1,018 hectares of HCA owned lands. In this plan the managed forest land parcels are at SCA and one land parcel at the Vinemount Swamp. These areas are identified for forest conservation and no harvesting is planned for the areas identified in the Managed Forest Plan A restoration plan is recommended for natural regeneration in all forest areas at SCA, and to control invasive species. See Appendix 5 for more information from the Managed Forest Plan.

5.16 Natural Areas Recommendations

The natural habitat features at SCA have been evaluated for restoration opportunities and invasive species removals. Priorities for natural areas conservation and restoration in this Master Plan are as follows:

.1 Conservation Targets for Saltfleet Conservation Area

Biodiversity conservation targets are a limited number of species or ecological communities that ecologists select to represent the biodiversity of a protected area, and that therefore serve as the focus for conservation investment. Thus, conservation targets are simply those ecosystems, communities, or species upon which we focus planning and management efforts. Because we use only a handful of targets to plan for biodiversity conservation, selecting the appropriate suite of targets is crucial to successful conservation planning and adaptive management. A coarse filter/fine filter approach was used when analyzing and describing conservation targets for SCA. For BC-1, the conservation target should be migratory bird and bat maternity colonies; SC-8 is migration corridors for animals and for Tapleystown and Vinemount Swamp, it is conservation of treed swamp/forests. These are important features for

each of these properties and their conservation will ensure that species and significant wildlife habitats are conserved over the 10 years of this Master Plan. It will also be important to monitor the created wetlands on both BC-1 and SC-8 and the impact their development had on existing natural heritage features (wetlands and creek corridors).

The savanna, escarpment (karst) and forested/swamp were identified as important areas for migratory land birds and bat maternity colonies at BC-1. These areas are primarily north of the Development Zone shown on the appended Master Plan Zones map. Trail development shown on the appended Trails Master Plan map is intended to steer clear of standing snag trees for bat maternity colonies. Trails development should be focused outside these zones to ensure snag trees remain standing for bat maternity colonies.

The overarching conservation target for SC-8 will likely be removed for the development of the wetland features on this property. As restoration will occur post wetland creation, it will be important to recreate the animal movement corridor along the creek edge and enhance this creek corridor.

The existing natural habitat features at all of the properties with the Saltfleet Conservation Area have been evaluated for restoration opportunities. In order to provide a clear overview of recommended restoration/enhancements the properties have been broken down into four distinct areas.

.1 BC-1

As stated above, the cultural thicket and savannas on this property are important for migratory birds and bat maternity roosts. The natural escarpment through this property is an important feature for wildlife, providing a variety of cover from thicket to savanna and open water seeps for a year-round water supply. Wetland cells have been created in the northern half of this property. These areas have been planted in a diversity of trees, shrubs and herbaceous plants. A Green-



ash swamp remains on the northern portion of the property. These trees are dying leaving a reduced canopy cover of mostly Bur Oak, with an understory of Common and Glossy buckthorn. Control of the Common and Glossy buckthorns in this area is recommended to improve the biodiversity of this wetland and limit the ability of buckthorn to move to the created wetland cells. As these removals occur, a diversity of tree species should be

planted to add stability and resilience to this remnant wetland. Common buckthorn removal should also occur along the hedgerows and forests within this property. It is recommended that the two western fallow fields remain open and allowed to transition to meadow and thicket habitat. This will enhance the habitat for Barn Swallow and Common Nighthawk, while not filling in the area of savanna. The eastern field should be restored to forest to allow for a larger upland forest tract on this property in the south-east corner. Remnant fences also occur on this property near the escarpment and seeps. It is recommended that these be removed to allow for wildlife movement. A monitoring program is also being developed for the created wetland to track how they change over time; what species start to use them and as an early warning for invasive species control. Planting within the created wetlands may be necessary depending how the area changes over time.

.2 SC-8

This location will be transitioned into wetland ponds over the next few years. It will be important that the plantings be re-established along the creek corridor to ensure the animal movement corridor is maintained. Invasive species such as Common buckthorn and Phragmites should be controlled pre and post wetland creation.

.3 Tapleystown Woods

Enhance biodiversity and long-term forest resiliency. The forest in the northern portion of this property is dominated by Sugar Maple. It was used for maple syrup production and appears as though species other than sugar maple were removed from this section. There is a very low diversity of other species within these forested areas. In order to ensure this forest is resilient and stable in the long term it is recommended that a diversity of trees and shrubs be planted in these forests. Recommendations would include diseases resistant butternut, shagbark and bitternut hickory, basswood and black walnut. Removal of invasive species is a high priority here as there is a large population of Dog Strangling Vine along the trail which is slowly moving into the forest. Common buckthorn is also present in portion of the property. It may be difficult to control as it occurs in the poison ivy thicket mostly.

.4 Vinemount Swamp

Portions of this large swamp were once dominated by Green Ash with some Swamp White and Bur Oak. Unfortunately, over time the Green Ash have died and the area has transitioned to a non-native shrub thicket of mainly Glossy and Common buckthorn. These are large areas of non-native species and specific strategies will be required to transition this difficult site back to native swamp. The appended capital budgets have accounted for increased cost for this work, but may need to be amended when specific restoration plans are available. Reed Canary Grass is beginning to grow in the meadow marsh adjacent to Fifth Road. This species should be controlled and removed from the meadow to ensure the existing biodiversity is maintained. Phragmites should be removed from along the Dofasco trail through the swamp, as it is currently confined to this narrow trail.

.2 Invasive Species in Saltfleet Conservation Area

The species detailed below are a threat to the biodiversity and conservation values in SCA. The following section details the invasive species that occur within the conservation area. Recommendations for prioritization for each species are detailed here.

.1 Common Buckthorn

Common buckthorn (*Rhamnus cathartica*) is a small tree or shrub that was introduced to Ontario from Eurasia. It was widely planted in farm hedgerows and fencerows as a wind break. It can survive in a wide range of conditions making it very good at invading a variety of habitats (Anderson, 2012a). Birds and small mammals feed on the berries of this plant, which has caused it to spread. Common buckthorn is widespread throughout the Saltfleet properties. The focus should begin on all fruiting female trees. These fruiting females can be treated with herbicides and the remaining smaller stems removed through volunteer events and work days. In areas where a large number of Common buckthorn are removed, or in areas of large ash die-off, native trees and shrubs should be planted to prevent invasion by another invasive species.

.2 Phragmites

This species of common reed from Eurasia is a perennial grass. It is not clear how it was transported to North America. Phragmites (*Phragmites australis*) is an aggressive plant that spreads quickly and out competes other native species in wetland habitats (Nichols, 2020). It forms large monocultures that decrease plant biodiversity and create poor habitat for wildlife.

Phragmites can be found on the property bordering Eighth Road East south of the Dofasco 2000 Trail. A large patch can also be found bordering the new constructed wetlands BC-1. This population bordering the wetland is being prioritized so it does not counteract efforts to create a functioning and biodiverse wetland ecosystem. A small population also occurs at SC-8. Both of these populations were treated for the first time in September 2022. It is likely eradication will take several years.

.3 Honeysuckle sp.

There are four main species of invasive honeysuckle (*Lonicera*) in Ontario which can be difficult to identify due to their tendency towards hybridization, and the lack of identifying characteristics (flowers and fruits) throughout much of the field season (Tassie and Sherman, 2014). These plants have been brought to North America for three centuries from Europe and Asia as an ornamental. Invasive honeysuckles can rapidly reproduce, grow quickly, and outcompete beneficial vegetation including our native honeysuckles. Their fruits are attractive to birds and mammals, which aid their spread. Background studies have identified the native honeysuckle *Lonicera dioica*, and the invasive honeysuckle *Lonicera tatarica* growing on all properties in SCA. While identification is easiest in the spring during bloom, hand pulling and weed wrenching smaller shrubs should be conducted in the fall as not to disturb the growth of any nearby spring ephemerals. Cutting and girdling larger shrubs should always be paired with the

application of herbicide to newly exposed woody material to prevent excessive suckering come next season. The first step will be to identify and map the honeysuckle populations in the spring to ensure only the invasive honeysuckles will receive treatment.

.4 Canada Thistle

Another perennial plant of waste places and fields, the Canada thistle (*Cirsium arvense*) has been in North America since the early settlers (MDA, n.d.a). It is mostly a pest to crops but can invade and take over other nearby meadows. The plant is a prolific seeder producing up to 5000 seeds a season, however the seeds don't spread very far. It is through vegetative cloning of the root that allows this plant to spread and push out other species. It is very important to follow clean equipment protocol as even the smallest piece of root can regrow. There is currently a large population of Canada thistle within BC-1 in the fields bordering the constructed wetlands. The most common control method is tilling prior to flower bud break, to deplete the root reserves (MDA, n.d.a).

.5 Dame's Rocket

This Eurasian biennial wildflower was introduced to North America in the 1600s and has since invaded many moist woodlands and open spaces (Johnson, 2010). The plant spreads through abundant seed production during its three month long blooming period. There is currently a small population of dame's rocket (*Hesperis matronalis*) in BC-1. The plants can be pulled relatively easily from moist soil before the seeds mature in the spring. Depletion of the seed bank can take many years.

.6 Erect Hedge Parsley

Erect hedge parsley (*Torilis japonica*) was introduced from Eurasia in 1917 for reasons unknown (Kendall, 2021). It is a small biennial plant with parsley or carrot like leaves and small clusters of white flowers. The seeds of this plant have a hooked coat, which allows them to stick onto passing people or wildlife and spread to new areas. Erect hedge parsley can grow in almost any habitat, and produces up to 7000 seeds per plant, making it a threat to numerous native ecosystems.

A small population of erect hedge parsley can be found in the Tapleystown Woods. Hand pulling of sporadic plants can be performed between April and July before seeds start to develop and mature. For smaller patches, covering the plants with a black tarp to cook them in the sun and prevent photosynthesis is an effective strategy.

.7 Dog Strangling Vine

Dog strangling vine (*Vincetoxicum rossicum*) is an extremely invasive perennial which forms thick mats of vines crowding out all other vegetation (Anderson, 2012b). It is unclear how the European native arrived in Canada, but the first record is from Toronto in 1899. Dog strangling vine is a successful invader through altering the chemical composition of the soil, growing so densely it dominates ground cover, and producing many seeds which are readily carried by the wind.

Small pockets of dog strangling vine creep into the Tapleystown Woods from the population bordering the Dofasco 2000 Trail. Individual plants can be dug up so that all parts of the root are removed from the soil. Alternatively, herbicides can be applied to plants before their seed pods fully develop (May to August). Tarping to desiccate plants is not a viable solution for this population due to the lack of sunlight reaching the forest floor in this area. It is likely multiple years of treatment will be required until the seedbank is depleted. If staff cannot meet this timeline, the seed pods should be removed from all plants before maturity in order to control the spread (Anderson, 2012b).

.8 Glossy Buckthorn

Glossy buckthorn (*Rhamnus frangula*) is a member of the buckthorn family that mainly grows in wet areas, but can be found growing alongside common buckthorn in other habitats (Anderson, 2012a). This is a non-native tree species introduced from Eurasia about 100 years ago (NCC, n.d.). This species forms dense thickets that shade out native species. They produce a dark berry that ripens in late summer and is eaten by birds. The birds disperse the seeds. It is very invasive due to its high seed production and tolerance for varied growing conditions. Glossy buckthorn is growing among common buckthorn across the all Saltfleet properties. Glossy buckthorn is not as established as common buckthorn, but it is spreading rapidly. It will be important to begin the removal process for this species. It tends to be a weak plant and is easily pulled when small. Herbicide treatment can follow the same methodology as common buckthorn since they are closely related and will likely be treated concurrently.

.9 Reed Canary Grass

The Reed Canary Grass (*Phalaris arundinacea*) that has become invasive in Ontario is thought to be a Eurasian cultivar brought to Ontario as forage for cattle (Anderson 2012c). It displaces native wetland plants and can decrease biodiversity. This plant can grow in a range of habitats and spreads quickly in wetlands. It spreads by both seeds and rhizomes. This species can be shaded out through the addition of trees and shrubs to invaded areas. Mulch can also be used to suppress the growth of Reed Canary Grass. Areas invaded with Reed Canary Grass in Saltfleet Conservation Area (BC-1 and Vinemount Swamp) can be planted with trees and shrubs. These plantings will need to be monitored a few times during the growing season to remove any grass that grows onto them to prevent smothering. Wood chips could be used in conjunction with planting to suppress the Reed Canary Grass and giving the trees and shrubs space to grow. Alternatively, herbicide can be applied in the early growing season (Anderson, 2012c). A large population of Reed Canary Grass can be found at the Fifth Road East wetland property, as well as SCA (BC-1) near the newly constructed wetlands. Controlling the population of Reed Canary Grass bordering the constructed wetlands should be prioritized so it does not counteract efforts to create a functioning and biodiverse wetland ecosystem.

.10 Sweet Cherry

Sweet cherry (*Prunus avium*) is a widely grown ornamental tree which is native to Europe and Asia (Invasive Plant Atlas, n.d.). It is often found growing in fields or other open areas as well as forest edges (King County, 2018). While it has the potential to crowd out native

plants, it does not pose a serious threat to most ecosystems but should be controlled when it may threaten a particularly desirable plant community (Ontario Invasive Plant Council, 2013). There is currently some Sweet cherry bordering HCA property at Taplestown Woods. This population should be monitored for spread and effects on the surrounding ecosystem.

.11 Winged Euonymus

Winged euonymus (*Euonymus alatus*) is an Asian ornamental shrub coveted for its stunning bright red fall foliage. However, this plant can create dense thickets in both forests and fields which outcompete native species (NRCS, n.d.). It tolerates a variety of environmental conditions, can reproduce vegetatively, and grows many seeds which can be spread by wildlife to colonize new areas. There is currently one Winged euonymus plant in Saltfleet at Taplestown Woods just off Powerline Road. This is a non-fruiting tree, which means it will not grow seeds to spread, however it should still be controlled to prevent vegetative reproduction. Winged euonymus can be dug out so all the roots are removed, or it can be treated with chemical herbicides (NRCS, n.d.).

.12 Cut – leaved Teasel

A perennial plant that occurs in a variety of habitats including meadows, waste areas and roadsides. Cut-leaved teasel (*Dipsacus laciniatus*) has high seed production and can spread and take over areas. In its first year it is a large rosette and by its second year can grow up to 2m high, shading out other meadow species (MDA, n.d.b).

It can be found in the Fifth Road East wetland property in low numbers. Annual cutting of these plants can occur in the spring to damage the taproot since its full removal can be difficult (MDA, n.d.b). Alternatively, the plant responds well to annual herbicide treatment during the main growing season. Eradication can be achieved in 3-5 years when the seed bank is depleted.

.13 European Privet

European privet (*Ligustrum vulgare*) is a highly invasive ornamental shrub or small tree that is native to Europe, Western Asia and Northern Africa. It was introduced in the early 1800s, and has since colonized a range of different habitats due to its tolerance for a variety of soil types and environmental conditions (CABI, 2021). Plants may produce 10,000 fruits per tree, which are then spread by wildlife to seed in different areas. European privet also reproduces vegetatively by its roots, so care must be taken not to spread root fragments during control efforts (CABI, 2021).

European Privet can be found in small numbers at the Fifth Road East wetland property. Small shrubs in newly established populations can be pulled or dug up and properly disposed of. Larger populations require foliar sprays of herbicide mixed with a surfactant between August and December. Larger trees which are difficult to foliar spray can receive a basal spray (Miller, 2003).

.14 Garlic mustard

This species was introduced in the 1800's from Europe as an edible herb for early pioneers in the spring. It is a biennial plant that produces seed in its second year (Anderson, 2012d). It can grow in a variety of conditions making it a very good invader in a variety of habitats. It easily outcompetes other native ground cover and can change the soil environments to favour its growth over others. Garlic Mustard (*Alliaria petiolata*) can be found growing in low numbers at the Fifth Road East wetland property. A slightly more established population can be found at Tapleystown Woods. Removal of this species is fairly straight forward with hand picking between April and June, before the plant goes to seed. With a dedicated effort over 5 years removal of this species can be achieved.

.15 Multiflora Rose

Multiflora rose (*Rosa multiflora*) is a large perennial shrub that was introduced to North America in the late 1700s for horticultural purposes, and was widely promoted in the 20th century for a variety of uses (Warne, 2018). This plant grows quickly, can self-pollinate, produce up to 500,000 seeds a year or more, and forms dense thorny thickets rapidly crowding out native biodiversity. Seeds are widely spread through animal's consumption of the plant's fruits, and can be viable in the seed bank for up to 20 years (Warne, 2018).

There is a small population growing in the Tapleystown Woods. Hand pulling is an effective control method for seedlings, however larger shrubs will aggressively re-sprout if cut without removing the roots. Therefore, a weed wrench and/or shovels should be used to fully remove the plant. This is a labour-intensive solution and should prioritize small populations and sensitive areas. Alternatively, glyphosate-based chemical herbicide can be applied in late summer or early fall. A follow up-treatment may be required the following year, with ongoing monitoring to eliminate new seedlings (Warne, 2018).



6.0 OVERALL SITE CONCEPT

This Master Plan for SCA balances the need to conserve the natural environment and wetland areas while accommodating visitors and generating day-use revenue.

As noted in Section 4.1 Study Area, the main focus of this plan is the Saltfleet Conservation Area property (182 acres) as this is the visitor entrance. This section outlines the key concepts for this Master Plan that have come out of staff workshops, meetings, detailed design sessions, site inventory. Public and stakeholder comments have also been considered in developing these concepts. See Appendix 1 for more information.

6.1 Natural Areas Development

The priority of this plan is to conserve and protect the natural areas and environmentally significant natural areas of the Escarpment. Accordingly, Nature Reserve and Natural Area Conservation Zones have been identified in this plan with management guidelines as outlined in Section 3.6. The ecological mapping and species documented within this plan are also provided as a baseline inventory to help guide future land management decisions and project planning. See Section 5.16 for more on the natural area recommendations.



Development in the natural areas will be limited by HCA. HCA's development focus in the natural areas will be securing the perimeter from unauthorized access; management of the recreational trail system; forest management, hazard tree removals and tree planting; invasive species management; and the design and construction of wetlands. With the creation of new wetlands will come the restoration of natural areas affected by the wetland construction; supplementary wetland plantings; and monitoring of the wetland functions and wildlife.

The wetland complex on the BC-1 property was constructed during the writing of this plan. Future wetland projects are in the planning phase for the SC-8 property (Fifth Road East and Green Mountain Road) and SC-5 property (see 2022 Devil's Punchbowl Master Plan for more information). There is also potential for additional wetland construction projects on lands yet to be acquired.

Naturalization of a portion of the former agricultural lands is recommended as a priority item in this plan, with action taken annually on invasive species control, tree planting, and stewardship to move this forward.

Site monitoring, annual maintenance and restoration programs, and ongoing visitor education will also be necessary to support the goals of these initiatives.

6.2 Conservation Area Development

The priority of this plan is the opening of the conservation area to the public, with visitor amenities for passive recreation and education. The main development focus will be to provide an improved main entrance, parking area, washrooms, trailhead orientation, and recreational trails on site and connecting to the Dofasco Trail. The secondary development focus will be to provide for conservation area operations with a separate service entrance off Second Road. Maintenance and equipment access will also be required for the wetland areas.

6.3 Day Use Activity Areas

Saltfleet's day use activity areas include the visitor main entrance and parking area, recreational trail system, access to the Dofasco Trail, and access to the constructed wetlands. Amenities to be provided with the recreational trail system are to include trail head kiosks or map boards, wayfinding and interpretive signage, lookout stations, and rest areas.

Passive recreation will be the focus for nature appreciation, hiking, dog-walking, and cycling. Open air structures and site furnishings are to be provided at the parking area for visitors arriving from the Dofasco Trail and First Road. Public washrooms are to be provided.

Visitor education on permitted activities will need to be provided to help conserve and protect the natural areas and wetlands. For example, cycling is not recommended on any seasonally flooded wetland trails, dogs are to be kept on leash, and recreational activities such as swimming and winter skating are not permitted in the wetland ponds.



6.4 Marketing

Marketing and communications activities for SCA provided by HCA include promotion through print, the HCA website, and on various social media platforms. During public engagement for this plan, three visitor surveys were conducted to gather information on SCA, Devil's Punchbowl, and the market lands with the Punchbowl. From May 18 to September 9, 2022, a total of 282 surveys were submitted by the public, of these 150 surveys were submitted for the

conservation area.

See Appendix 5 for key highlights from the visitor surveys. These surveys will help inform future marketing materials for SCA.

Key marketing items from the surveys and staff workshops to be addressed in the lifespan of this Master Plan include the following:

- Provide safe and accessible visitor amenities: parking, public washrooms, and recreational trails.
- Provide educational information for Saltfleet Conservation Area focused on: nature, flora and fauna identification, bird migration and bird species, wetlands, geology, land history, cultural history of this area.
- Provide guided tours: the wetlands, birdwatching, natural and cultural history of the area.
- Provide self-guided tours by means of interpretive materials, signage, and wayfinding signage
- Provide information on the importance of preserving nature and protecting it from damage.
- Help connect people to nature by promoting SCA's amenities for community recreation, health and well-being.



7.0 CONSERVATION AREA MANAGEMENT

7.1 Land and Water Management

.1 Management Planning

Land and water management planning will be accomplished through adherence to the guidelines of the Conservation Area Zones noted in this Master Plan, and through additional resource management plans developed by HCA as necessary during the life of this Master Plan. The overall intent will be to ensure protection and conservation of the significant natural areas at Saltfleet noted as Nature Reserve (Wetland) and Natural Zones, and the Cultural Heritage Zones noted on the maps in Appendix 1, as well as implementation of the Natural Areas Recommendations noted in Section 5.16.

Significant natural heritage features identified at SCA include Environmentally Significant Areas (ESA) and wetlands. These areas are identified in the City of Hamilton Official Plan as Core Areas and part of the Natural Heritage System. The Official Plan provides for the protection of such features, and no new development or site alterations are permitted within or adjacent to ESA's unless it can be shown, through an Environmental Impact Statement (EIS) that there will be no negative impacts on the ecological features or functions of the ESA. The floodplain associated with Battlefield Creek is also protected from development under both provincial and HCA policies. Significant wildlife habitat is also protected under provincial policy.

Significant cultural heritage features at SCA include the registered archaeological sites documented for the BC-1 wetland project. With their cultural significance and covenant on title noted in Section 4.7, future capital projects will need to include archaeological investigations in their scope of works. In the absence of archaeological investigations, soil disturbance for site operations and maintenance is not permitted. However, minor landscaping activities on or above the surface of the site including the addition of topsoil up to 50cm maximum fill (combined existing and new fills) and grass cutting are permissible.

Waste consisting of natural materials will be reused or composted inside the conservation area where feasible and appropriate. Otherwise, all solid waste will be removed from the conservation area for recycling or disposal.

Wherever possible, new development or redevelopment will be undertaken so as not to disrupt natural drainage. Zone resource management plans will seek to restore natural drainage where it has been disrupted by past or present development.

.2 Public Infrastructure – Utilities, Trails and Transportation

Public infrastructure such as utility corridors (watermains, storm and sanitary sewers, natural gas or oil pipelines, hydro and communication corridors), trails (footpaths, boardwalks) and transportation links may cross conservation area lands. These uses may also have associated rights-of-way, land use agreements, licenses of occupation, permits etc. that are to be considered in the management of the conservation area and when implementing items from

this Master Plan.

When new public infrastructure projects are proposed within conservation area owned lands, such uses will be subject, but not limited to the following criteria:

- The need for the project, area of construction disturbance, and potential site disruption such as soil erosion, flooding, and vegetation loss.
- To maintain or where possible improve or restore key ecological linkages, habitat, and wildlife movement corridors.
- The potential public benefits of the project for research, education, or recreation in the conservation area.

HCA may require detailed environmental assessments, studies, and resource management plans in order to support such land uses.

7.2 Vegetation Management

This section supplements the natural areas recommendations noted in Section 5.16.

Where active management is required for a particular plant or animal species, it will be accomplished through an acceptable HCA resource management strategy considering the guidelines outlined in this Master Plan, and in accordance with policies of all governing agencies.

Forests will be managed in accordance with the MNR approved HCA Managed Forest Plan 2018 - 2037. Forest plantations and treed areas will also be managed to remove hazard trees and fallen logs in areas of public use such as recreational trails and picnic areas. Forest management is to be carried out with generally accepted sustainable forestry practices. See Appendix 5 for more information from the HCA Managed Forest Plan.

Invasive species in the conservation area are a high priority for management to maintain biodiversity and conservation values. See Section 5.16 for more information on invasive species vegetation management.

Additional non-native plant species will not be deliberately introduced into the conservation area. Introduction of any new plant species by HCA will consider the biodiversity of this site and contiguous surroundings, historical data of species present in the area, native species research findings, and additional relevant species inventories, within an approved restoration and stewardship strategy. In this Master Plan “non-native” means species not native to Ontario as well as species native to Ontario but not to SCA. If established non-native plant species threaten natural heritage values, a program for their eradication will be developed subject to specific guidelines noted in the natural heritage inventory of this Master Plan.

Vegetation may be mowed only:

- Along the conservation area boundary, where mowing would assist in clearer

boundary identification.

- In the development zone of this Master Plan to support public use of the open space, and only to the extent necessary.
- As required along roadways and recreational trails for safety.
- To assist in the control of invasive species, trees and brush may be cut and pruned only.
- To enable resource management or facility development specifically authorized by this Master Plan or an HCA approved resource management or other implementation plan.
- To ensure public safety.
- In service easements i.e., Utility corridors, subject to specific service agreements.

Trees may not be cut for the sole purpose of providing firewood. Trees and brush cut in nature reserve and natural zones outside of the forest plantations will be left to deteriorate naturally as close as possible to where they have been felled, or if that is not feasible, may be used for firewood or wood chips in the conservation area.

Native insects and diseases affecting vegetation will be allowed to progress naturally, except where they threaten significant natural heritage values in nature reserve and natural zones, or significant aesthetic and infrastructure values in development zones. Non-native insects and diseases will be controlled where feasible. Where controls are undertaken, it will be directed as narrowly as possible to the specific insect or disease so as to have minimal effects on the surrounding environment. Biological controls will be used whenever possible.

Fires in the day use area are not permitted.

Chemical fertilizers, herbicides, pesticides and suppressants will not be used for any vegetation management purpose except:

- Insect and disease control under the conditions set out in this section of the Master Plan.
- Eradication of non-native species where it has been demonstrated other methods are not feasible.
- Control of poison ivy in development zones.

7.3 Fish and Wildlife Management

Where applicable on the conservation area property, fisheries management will seek to maintain and enhance native, self-sustaining fish populations. Where applicable, waters in nature reserve zones may be closed to angling temporarily or permanently for fisheries or wildlife research or management purposes.

Currently no fishery exists on the property as the species present are mainly not game fish. These populations are stressed from the intermittent nature of the creek and the local agricultural drainage impacts. Thus, no commercial or recreational fishing/harvest will be allowed on the properties. See Section 5.2 for more information.

For Terrestrial Flora and Fauna there is no harvest allowed within the conservation area to protect the populations with an exception for Research (see Section 7.7)

For wildlife/human conflict HCA has developed the Hamilton Conservation Authority Wildlife Conflict Management Strategy (WCMS) this strategy outlines the process and methods staff are to follow when dealing with any animal related issues in the Saltfleet Conservation Area. This document was produced by the Hamilton Conservation Authority Wildlife Management Committee (WMC). The WMC was a special committee of the Hamilton Conservation Authority (HCA) that was established in May 2014 based on HCA staff recommendation and at the direction of the HCA Board of Directors. The purpose of the WMC was to develop best management protocols and practices for the management of wildlife on HCA lands.

See Section 5.0 for more information on wildlife populations inventoried and to be considered in this plan. All capital assets proposed for the conservation area are to be evaluated for wildlife impacts, and best management practices and strategies developed that address both wildlife management and capital asset protection.

Additional non-native animal species will not be deliberately introduced to the conservation area. If already established non-native species threaten the conservation area values, a program for their eradication may be developed if feasible and practical. Missing native species may be re-introduced, and existing populations replenished if feasible and acceptable to HCA.

7.4 Cultural Heritage Management

Significant cultural heritage features, such as the registered archaeological sites, will be protected from incompatible development in the conservation area. Incompatible resource uses and recreational activities will be restricted or prohibited where necessary to protect cultural heritage resources. The cultural heritage zone set out in this plan is intended to define the area on site where this protection is to be enforced by HCA.

See Sections 4.6 and 4.7 for more information on the cultural heritage features and restrictive covenant placed on the documented archaeological sites.

Archaeological and historical artifacts may not be removed or heritage landscapes altered. Management strategies for any archaeological sites found in the future may range from allowing the sites to remain without interference, to research, excavation, and rehabilitation in accordance with the Ontario Heritage Act and associated governing agencies. Protection and management will be undertaken in consultation with all governing agencies and First Nations.

7.5 Conservation Area Operations

HCA will provide staff with information and resources as required to operate the conservation area on a day-to-day basis. This will include specific direction for the management and operation of all facilities and activities and address such topics as budgets, staffing, maintenance, enforcement and emergency services. The operation plan will be reviewed annually and updated as required to ensure adequate resources and staffing are available to manage the property and level of visitation.

Self-serve facilities may be developed, and individual volunteers and partner organizations may be involved in conservation area programs as approved by the HCA.

HCA has the right to suspend operations of any facilities or services due to funding limitations, but in so doing will ensure that heritage values are not impaired and customer service standards are affected as little as possible.

New business practices may be introduced into the conservation area operations in accordance with HCA policy such as:

- Improving operating efficiency and controlling costs
- Contracting out some operating functions.
- Improving customer service standards.

7.6 Education

Education in the conservation area is intended to develop visitors' awareness and appreciation of Ontario's natural and cultural heritage, fostering a commitment to protect that heritage for all generations. Education opportunities are meant to be educational and recreational, formal and informal, and accessible to all. Information, education, and outdoor recreation are the three main components of education in the conservation area. The level of service provided at the conservation area will be determined by its significance and visitation.

See Section 6.4 and Appendix 5 survey highlights, for more information on education and interpretive items obtained through public consultation and surveys.

7.7 Research

Saltfleet, like all of HCA's properties, provide in essence an opportunity for living laboratories. HCA Ecologists monitor the health of lands using established protocols as well when needed can develop special research programs to answer resource related questions.

Outside Research by qualified individuals that contributes to the knowledge of natural and cultural history and to environmental and recreational management will be encouraged by HCA staff.

All research projects will require authorization from HCA and authorization is obtained by contacting the staff ecologists who administer the process and issue letters of permission.

7.8 Recreation

From consultation and surveys for this plan, both hiking and cycling were noted as key recreational activities for SCA. Cyclists are interested in trail riding in the study area, on the Dofasco 2000 Trail, and connecting to the City of Hamilton recreational trail network. Safe and accessible trails for all age groups and abilities are also desired.



The conservation area is to operate as a day-use area open from sunrise to sunset, year-round.

Entry to SCA will be controlled year-round, and HCA will enforce the collection of entrance fees from visitors. Day use parking spaces are provided on a first come, first serve basis and visitors may be restricted from entering the conservation area when the parking areas are full.

The following motorized recreational activities will not be permitted in the conservation area:

- All-terrain vehicle use
- Motor bikes on trails
- Snowmobiling
- Unmanned aerial vehicle (UAV)
- All motor-powered watercraft in the constructed ponds/wetlands

In order to sustain the wetland functions for flood control and protect the wetland ecosystem, all water-based recreational activities including fishing, swimming, personal watercraft (canoe, kayak, SUP) and winter skating are not permitted.

The following recreational activities are permitted in the conservation area:

- Hiking
- Dog Walking
- Cycling (on designated trails)

- Nature Appreciation: Wetlands, karst Features, Wildlife, Birdwatching
- Picnicking
- Geocaching
- Winter Activities: Snowshoeing, Cross Country Skiing

A long-term goal of this Master Plan is to provide visitors with appropriate, high quality sustainable recreational experiences. Recreational opportunities are to be provided that are appropriate to the conservation area and Master Plan zones outlined in Section 3.6.

7.9 Partnerships

HCA values the community support from area residents and landowners, businesses, service clubs, interested First Nations, volunteers, and volunteer organizations that currently or could contribute in a variety of ways at SCA. The HCA will continue to nurture support and will seek out new opportunities for partnerships. Collaborative partnerships are welcomed to help HCA efficiently achieve its goals and objectives at the conservation area.

HCA also values the relationships with neighbouring landowners and working cooperatively to manage natural areas and the species that utilize and inhabit Saltfleet's natural areas. HCA Stewardship Action Plans, public consultation, and stewardship work are examples of this and are to be encouraged for the life of this Master Plan.

Volunteers are governed by volunteer policies set by HCA. Volunteer programs shall be maintained and developed to provide for recruitment, orientation, training, supervision, health and safety instruction, evaluation and recognition. Volunteer programs shall be considered in all business decisions made by HCA in the operation of this conservation area.

7.10 Paid Staff

A supplemental operations plan is recommended to be developed for SCA by HCA staff once this Master Plan is adopted.

SCA, similar to staffing at other conservation areas, includes full time permanent employees and part time casual employees to undertake its operations.

In addition, staff from other departments at HCA are involved in varying capacities with the management and operation of the conservation area. Staff may also be involved in supervising the activities of outside consultants, partners, or contractors retained by HCA.

8.0 FINANCIAL

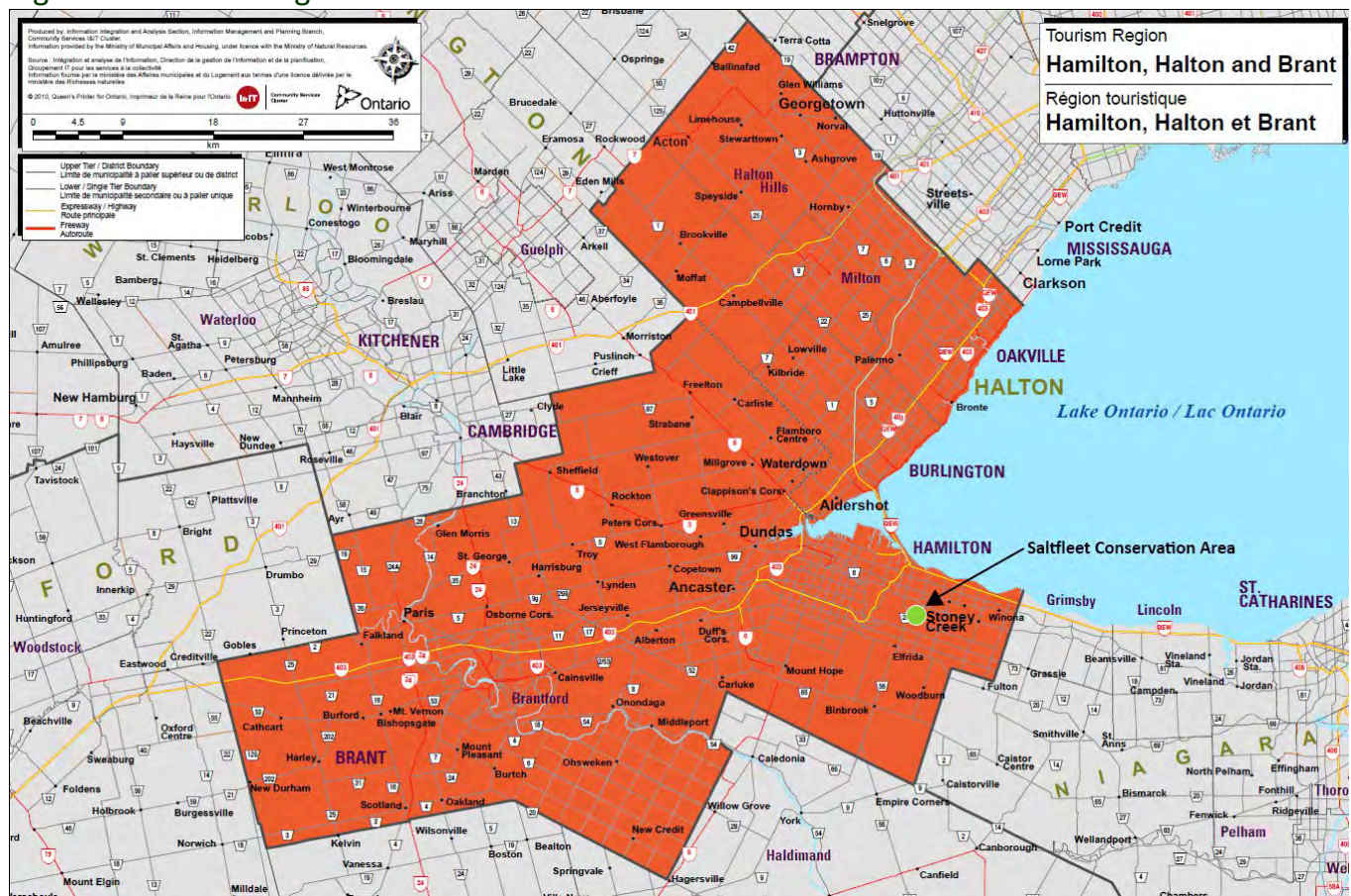
8.1 Attendance and Revenue Forecasts

Visitor attendance data, and operating revenue and expenses for SCA is appended. Further analysis of the visitor data is in Section 8.4.

Visitation is anticipated to grow steadily during the life of this plan, as day-use facilities are provided by HCA and visitors experience SCA and the Devil’s Punchbowl. The parking lot and trails will help support overflow of visitors seeking to park at Devil’s Punchbowl. Day use visitation offers opportunities for revenue generation for HCA’s East Mountain business unit. Marketing of the HCA membership pass program, as well as special events and programs hosted at the conservation area may also help to attract and retain repeat visitors.

With the newly constructed wetlands completed and the site now opened to the public, more detailed design is recommended to improve the main entrance, parking, trail access, washroom facilities, and passive recreational amenities. See Section 8.2 for more information.

Figure 9. Tourism Region



Source: Ontario Ministry of Tourism, Culture and Sport.

8.2 Capital Projects

The capital development priorities list in Appendix 2 provides preliminary estimates for the development envisioned in the Master Plan. As noted in Section 3.7, the following capital development priorities are proposed for the next ten years at SCA.

.1 Natural Areas Development

For conservation and protection of the natural environment, establishment of the new wetland areas, and naturalization of the former agricultural lands. Key items include:

- Design and construction of new wetland on SC-8 property.
- Wetland naturalization plantings and management: invasive species control, restoration, berms.
- Provide equipment access and turn-around areas for the wetland berms.
- Install perimeter fencing to restrict unauthorized access.
- Install wetland trail system and interpretive signage.
- Conversion of the agricultural lands (resource management zones) to naturalized areas.
- Forest management and natural areas stewardship.
- Further investigation of the karst features for their management and interpretation.



.2 Conservation Area Development

To support the opening of the conservation area to the public, with visitor amenities for recreation and education. Key items include:

- Improved main visitor entrance: roadways, signage, automated gates, lighting, parking.
- Permanent washroom facilities.
- Site furnishings: picnic tables, trash cans, rest areas (natural stone seating), bike racks.

.3 Day Use Activity Areas

To support passive recreation for visitors arriving from the Dofasco Trail and First Road. Key items include:

- Recreational trail system: Trail kiosks and wayfinding signage; new trails to the wetlands, Dofasco Trail, and karst features.
- Lookout Areas: for the wetlands and the karst features on the property.
- Education: Interpretive signage, digital information, mobile information applications.

8.3 Funding Sources

Funding totaling \$4.75M was secured through the Heritage Green Community Trust, the City of Hamilton, the Hamilton Conservation Foundation and the HCA Land Acquisition Fund for the acquisition of Saltfleet Conservation Area. The Heritage Green Community Trust donated \$2 million towards the acquisition and development of SCA and has pledged an additional \$2 million by 2026 for further wetland development. The first wetland trail that opened to the public in September 2022 was named the Heritage Green Community Trust Trail. The City of Hamilton is also a key partner and donor to the wetland project.

Grants from various sources including the Greenbelt Foundation, RBC Foundation and Green Municipal Fund have also been received and staff will continue to apply for grants and funding as sources are identified.

HCA's operation of SCA is to be primarily self-funded. User and membership fees generated by the properties in the East Mountain business unit are anticipated to be the primary funding source for the operation of the conservation area. Automated gates are to be installed at SCA to help add to the revenue of the business unit.

Revenue is anticipated to be generated through gate admissions (gate and pre-sold tickets), and vehicle passes to the parking area. Special events and programs may provide a source of additional revenue, provided they do not disrupt the daily activities in the conservation area. Financing for special projects and annual capital development will continue to be provided through grants, sponsorship, corporate donations, and private donations. The Hamilton Conservation Foundation also provides funding for specific projects. There is good potential for increasing donor funding, donor recognition is also a key element that needs to be nurtured and sustained.

8.4 Business Model

See Appendix 4 for the estimated operating revenue and expenses for this new conservation area. These estimates are based on current operating revenues from HCA's East Mountain business unit, and revenues anticipated from the installation of a gated 40 to 50 car parking lot as noted on the Site Concept Maps in Appendix 1. A supplemental operations plan is recommended to be developed for SCA by HCA staff once this Master Plan is adopted.

HCA receives a levy from the City of Hamilton and the Township of Puslinch that forms part of the operating budget. The remainder of the budget is funded through user fees, membership fees, grants, and donations. These dollars directly contribute to conservation work throughout HCA's watershed and preserve heritage sites on HCA lands. Financial statements are audited annually and available to the public once approved by HCA's Board of Directors.

User and membership fees help pay for items such as trail maintenance, emergency services and procedures, and all the items required to keep the conservation area open to the public.

Sustaining revenue at Saltfleet will require HCA to refine their marketing, business, and development strategies to:

- Continue to attract day use visitors and provide quality recreational facilities and services so they will be encouraged to return.
- Continue to market the HCA visitor pass card for repeat visitors and provide card swipe access to capture revenue from visitors entering the conservation area.
- Diligently sustain the natural resource value of the conservation area by limiting activities to the zones prescribed in this Master Plan.
- Continually monitor day use visitation and conduct on-site and market research campaigns as necessary to measure visitor satisfaction.
- Continue to explore pilot projects and best management practices as means of operating efficiently and growing revenue.
- Continue to leverage municipal tourism industry partnerships, public relations, community outreach, and corporate sponsorship.

Cost recovery is a prime requirement for all services and programs delivered at SCA. In the development of programs, the following factors will be considered: anticipated attendance, income sources, market, volunteer resources, HCA staffing requirements, advertising, insurance, administration, operation costs and maintenance expenses.

Concepts embodied in this Master Plan are to be weighed against the marketing demands for increased performance, attendance, programming, market penetration, awareness, and ultimately financial return.



9.0 PROGRAMMING

9.1 Special Events and Programming

Parking, trail access, and washroom facilities are essential for hosting special events and programs in the conservation area. Temporary accessible washrooms (portable toilet) are to be provided until permanent washroom facilities can be implemented.

SCA may be used as a filming location to generate revenue, with strict procedures in place so the integrity of the site is not sacrificed.

Community and school groups and organizations are welcomed to book visits to the property for educational programs, site tours, day-use activity programs etc. with strict procedures in place so the integrity of the site is not sacrificed.

9.2 Education and Interpretive Programs

Education and interpretive programs provide an opportunity to entice new visitors and provide variety for repeat visitors. Opportunities range from self-guided tours with interpretive signs or mobile device story spots along the trail system, to hands-on activities, educational demonstrations, live shows, workshops, and more. Some potential themes that could be explored include:

- Water management and flood control
- Constructed wetlands
- Bird watching
- Local history and the archaeology of this site
- Karst topography
- The Niagara Escarpment
- Role of Conservation Authorities
- Climate Change

All programs should relate to HCA's strategic value of providing outdoor learning experiences and increasing knowledge and awareness of the value of our environment and heritage.

10. SUMMARY

Saltfleet Conservation Area is HCA's newest area to explore and boasts nearly 147 ha (363 acres) of unique natural features. The acquisition of land for this conservation area was made possible through donations from the City of Hamilton and Heritage Green Community Trust.

SCA is part of a larger long-term plan to reduce downstream flood risk and erosion to residential and commercial properties below the Escarpment in Stoney Creek. The Upper Stoney Creek and Battlefield watershed was selected for the creation of four new wetlands in support of this plan. The wetlands at SCA are the first to be constructed. The second wetland is planned upstream on the SC-8 land parcel. The third wetland is targeted for installation near the Devil's Punchbowl, on lands recently acquired by HCA. A new management plan for Devil's Punchbowl is being developed with this plan in mind. The fourth wetland is expected to be developed as additional land is acquired.

The conservation area wetlands, marshy fields and woodlots provide habitat for waterfowl, migratory and breeding birds, as well as bats and other significant species. There are also natural and cultural history features on site to be interpreted with further trail development.

During the writing of this plan SCA re-opened to the public on September 23, 2022. The Heritage Green Community Trust Trail is the first trail installed for visitors to view one wetland area and access the Dofasco 2000 Trail. Further trails are outlined in this plan to enhance public access, nature appreciation, and educational opportunities.



This Master Plan identifies the natural features of the property to be protected, natural area management recommendations, and land use zones intended to help guide future planning, development, and management of the conservation area. Moving forward over the next ten years this plan will help guide the development and operation of this new conservation area in support of these goals.

11.0 APPENDIX CONTENTS

APPENDIX 1	Mapping
APPENDIX 2	Capital Development Priorities
APPENDIX 3	Operating Revenue and Expenses
APPENDIX 4	Visitor Data: Attendance, Visitor Surveys
APPENDIX 5	Managed Forest Plan Recommendations 2018 – 2037
APPENDIX 6	Natural Inventory – Species Lists, References
APPENDIX 7	References

APPENDIX 1

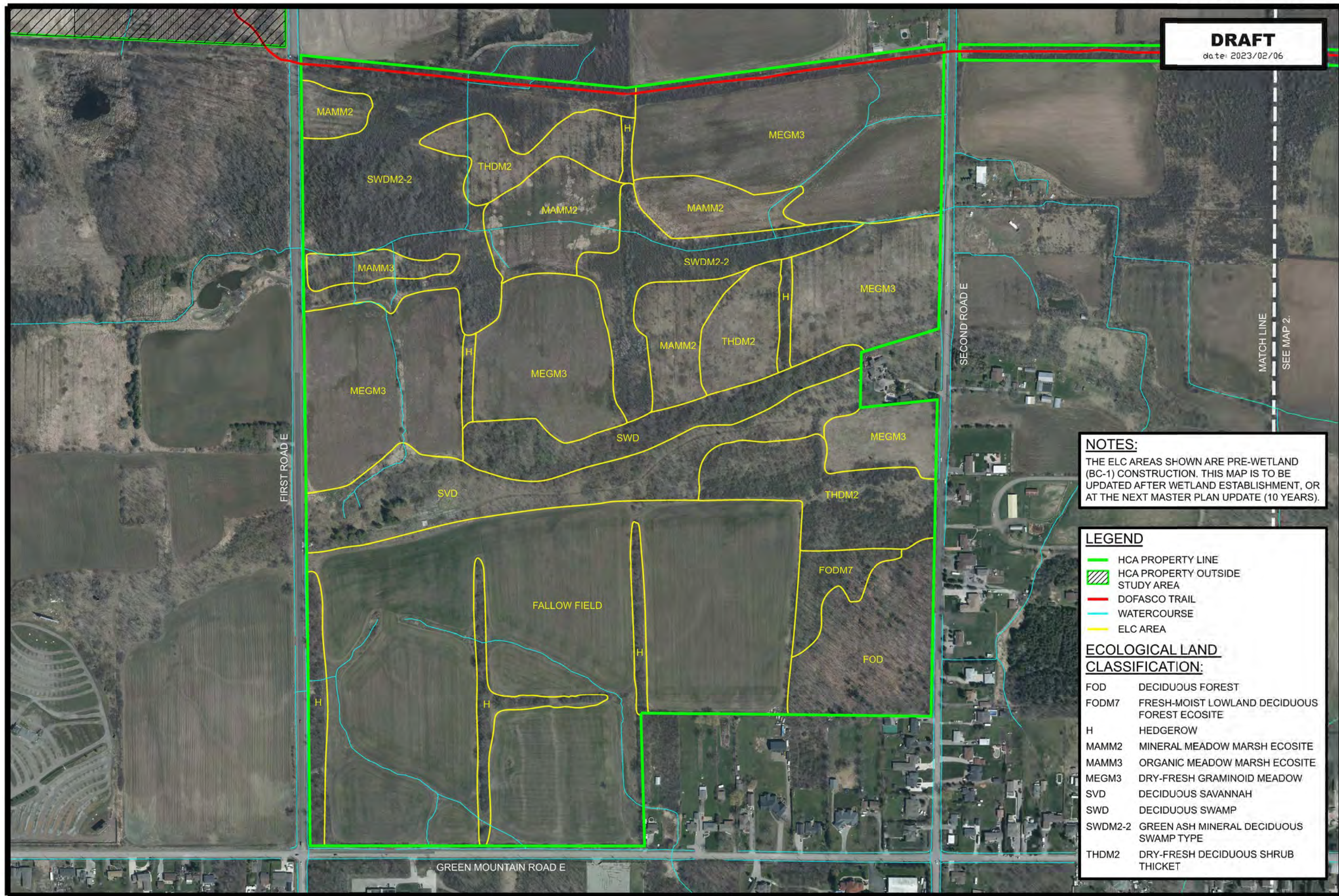
Mapping

Map 1	Ecological Land Classification 1
Map 2	Ecological Land Classification 2
Map 3	Master Plan Zones
Map 4	Master Plan Zones
Map 5	Trails Master Plan
Map 6	Site Concept – Main Site
Map 7	Site Concept – Satellite Sites

DRAFT
date: 2023/02/06



DATE: 2023/02/06



NOTES:
THE ELC AREAS SHOWN ARE PRE-WETLAND (BC-1) CONSTRUCTION. THIS MAP IS TO BE UPDATED AFTER WETLAND ESTABLISHMENT, OR AT THE NEXT MASTER PLAN UPDATE (10 YEARS).

LEGEND

- HCA PROPERTY LINE
- HCA PROPERTY OUTSIDE STUDY AREA
- DOFASCO TRAIL
- WATERCOURSE
- ELC AREA

ECOLOGICAL LAND CLASSIFICATION:

FOD	DECIDUOUS FOREST
FODM7	FRESH-MOIST LOWLAND DECIDUOUS FOREST ECOSITE
H	HEDGEROW
MAMM2	MINERAL MEADOW MARSH ECOSITE
MAMM3	ORGANIC MEADOW MARSH ECOSITE
MEGM3	DRY-FRESH GRAMINOID MEADOW
SVD	DECIDUOUS SAVANNAH
SWD	DECIDUOUS SWAMP
SWDM2-2	GREEN ASH MINERAL DECIDUOUS SWAMP TYPE
THDM2	DRY-FRESH DECIDUOUS SHRUB THICKET

**ECOLOGICAL LAND CLASSIFICATION
SALTFLEET C.A. MASTER PLAN**



DRAFT

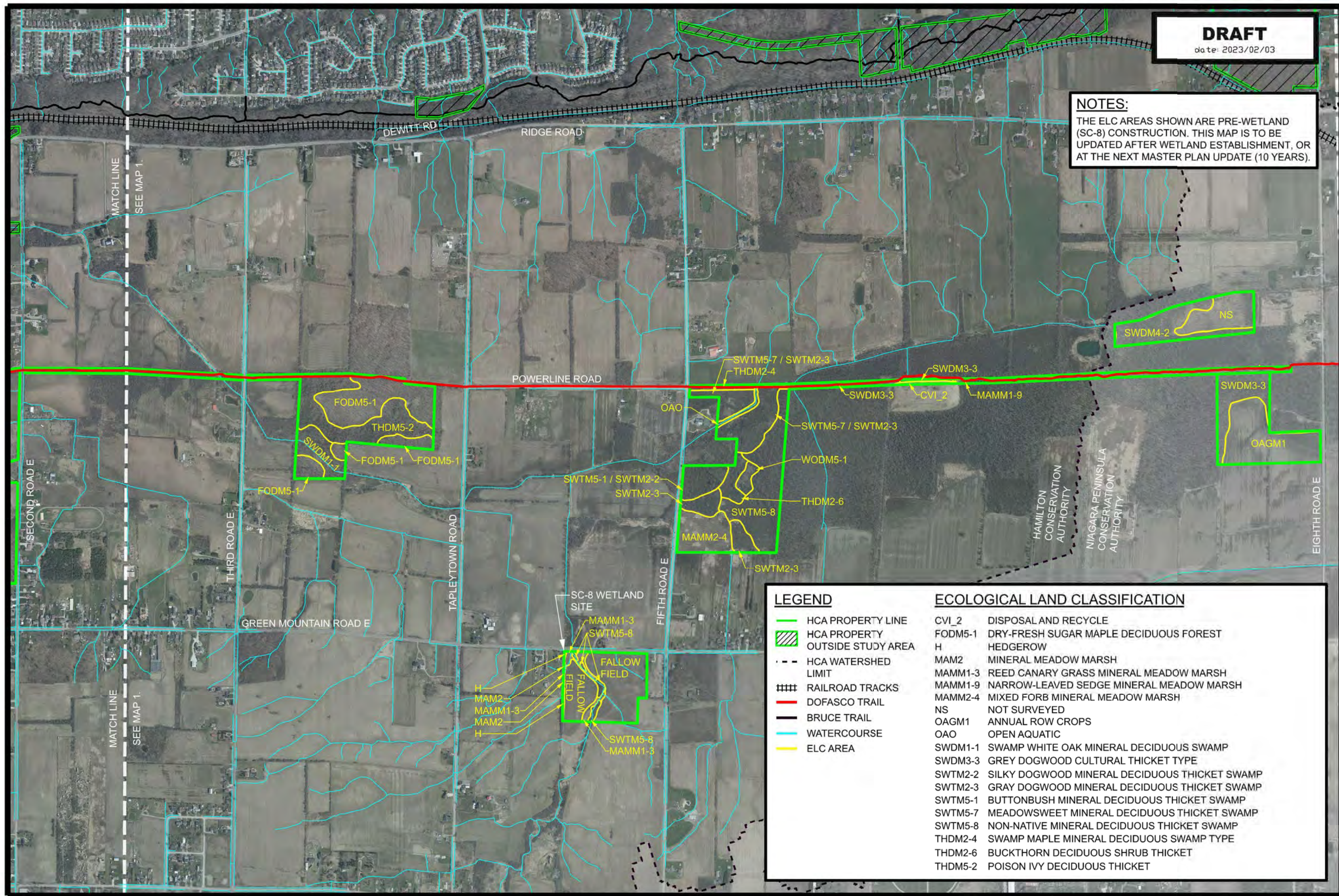
date: 2023/02/03



NOTES:
 THE ELC AREAS SHOWN ARE PRE-WETLAND (SC-8) CONSTRUCTION. THIS MAP IS TO BE UPDATED AFTER WETLAND ESTABLISHMENT, OR AT THE NEXT MASTER PLAN UPDATE (10 YEARS).

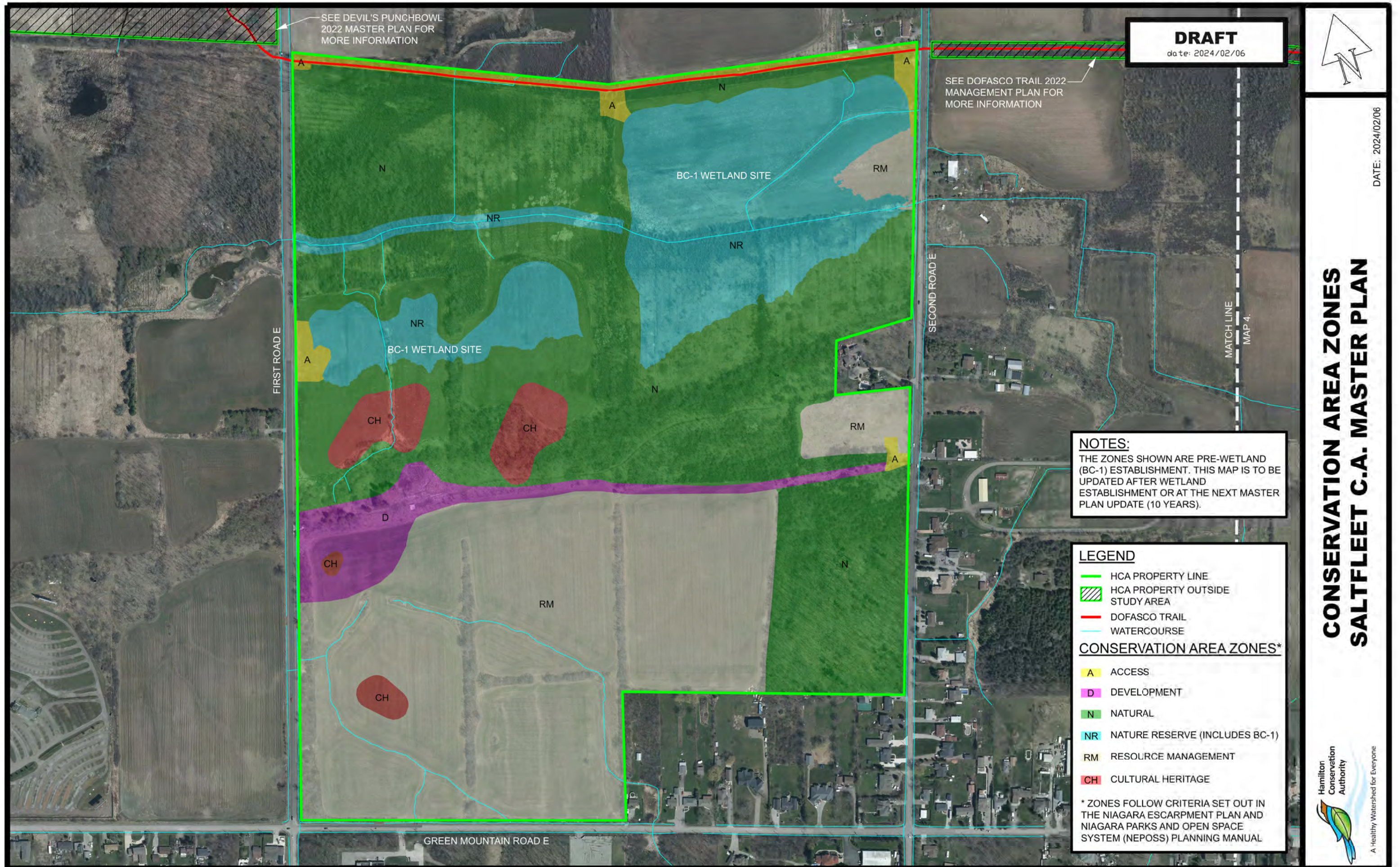
DATE: 2023/02/03

**ECOLOGICAL LAND CLASSIFICATION
 SALTFLILET C.A. MASTER PLAN**



LEGEND		ECOLOGICAL LAND CLASSIFICATION	
	HCA PROPERTY LINE	CVI_2	DISPOSAL AND RECYCLE
	HCA PROPERTY OUTSIDE STUDY AREA	FODM5-1	DRY-FRESH SUGAR MAPLE DECIDUOUS FOREST
	HCA WATERSHED LIMIT	H	HEDGEROW
	RAILROAD TRACKS	MAM2	MINERAL MEADOW MARSH
	DOFASCO TRAIL	MAMM1-3	REED CANARY GRASS MINERAL MEADOW MARSH
	BRUCE TRAIL	MAMM1-9	NARROW-LEAVED SEDGE MINERAL MEADOW MARSH
	WATERCOURSE	MAMM2-4	MIXED FORB MINERAL MEADOW MARSH
	ELC AREA	NS	NOT SURVEYED
		OAGM1	ANNUAL ROW CROPS
		OAO	OPEN AQUATIC
		SWDM1-1	SWAMP WHITE OAK MINERAL DECIDUOUS SWAMP
		SWDM3-3	GREY DOGWOOD CULTURAL THICKET TYPE
		SWTM2-2	SILKY DOGWOOD MINERAL DECIDUOUS THICKET SWAMP
		SWTM2-3	GRAY DOGWOOD MINERAL DECIDUOUS THICKET SWAMP
		SWTM5-1	BUTTONBUSH MINERAL DECIDUOUS THICKET SWAMP
		SWTM5-7	MEADOWSWEET MINERAL DECIDUOUS THICKET SWAMP
		SWTM5-8	NON-NATIVE MINERAL DECIDUOUS THICKET SWAMP
		THDM2-4	SWAMP MAPLE MINERAL DECIDUOUS SWAMP TYPE
		THDM2-6	BUCKTHORN DECIDUOUS SHRUB THICKET
		THDM5-2	POISON IVY DECIDUOUS THICKET





DRAFT
date: 2024/02/06

NOTES:
THE ZONES SHOWN ARE PRE-WETLAND (BC-1) ESTABLISHMENT. THIS MAP IS TO BE UPDATED AFTER WETLAND ESTABLISHMENT OR AT THE NEXT MASTER PLAN UPDATE (10 YEARS).

LEGEND

- HCA PROPERTY LINE
- HCA PROPERTY OUTSIDE STUDY AREA
- DOFASCO TRAIL
- WATERCOURSE

CONSERVATION AREA ZONES*

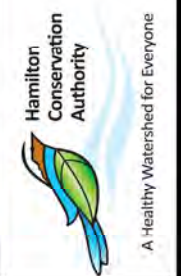
- A ACCESS
- D DEVELOPMENT
- N NATURAL
- NR NATURE RESERVE (INCLUDES BC-1)
- RM RESOURCE MANAGEMENT
- CH CULTURAL HERITAGE

* ZONES FOLLOW CRITERIA SET OUT IN THE NIAGARA ESCARPMENT PLAN AND NIAGARA PARKS AND OPEN SPACE SYSTEM (NEPOSS) PLANNING MANUAL



DATE: 2024/02/06

**CONSERVATION AREA ZONES
SALTFLEET C.A. MASTER PLAN**



DRAFT
date: 2023/02/03



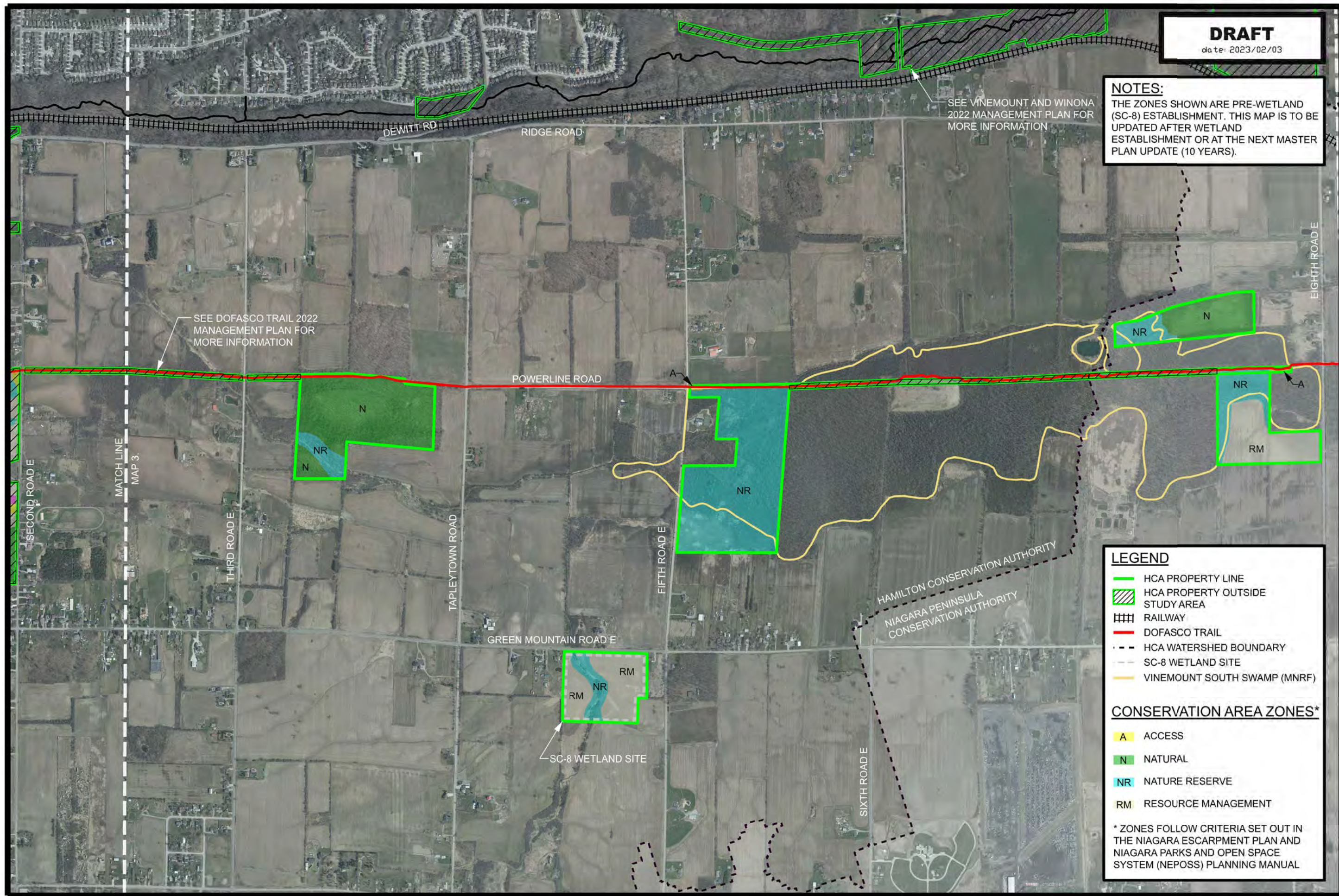
NOTES:
THE ZONES SHOWN ARE PRE-WETLAND (SC-8) ESTABLISHMENT. THIS MAP IS TO BE UPDATED AFTER WETLAND ESTABLISHMENT OR AT THE NEXT MASTER PLAN UPDATE (10 YEARS).

SEE VINEMOUNT AND WINONA 2022 MANAGEMENT PLAN FOR MORE INFORMATION

SEE DOFASCO TRAIL 2022 MANAGEMENT PLAN FOR MORE INFORMATION

DATE: 2023/02/03

**CONSERVATION AREA ZONES
SALTFLEET C.A. MASTER PLAN**



LEGEND

- HCA PROPERTY LINE
- ▨ HCA PROPERTY OUTSIDE STUDY AREA
- ▩ RAILWAY
- DOFASCO TRAIL
- - - HCA WATERSHED BOUNDARY
- - - SC-8 WETLAND SITE
- VINEMOUNT SOUTH SWAMP (MNR)

CONSERVATION AREA ZONES*

- A ACCESS
- N NATURAL
- NR NATURE RESERVE
- RM RESOURCE MANAGEMENT

* ZONES FOLLOW CRITERIA SET OUT IN THE NIAGARA ESCARPMENT PLAN AND NIAGARA PARKS AND OPEN SPACE SYSTEM (NEPOSS) PLANNING MANUAL

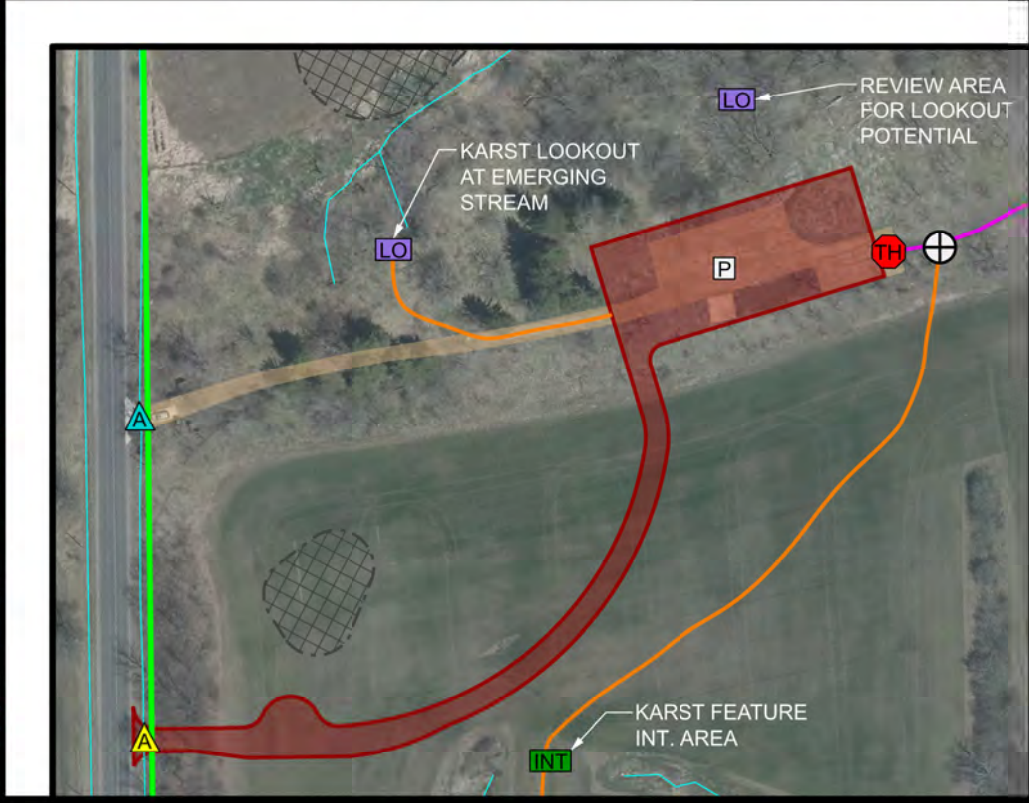
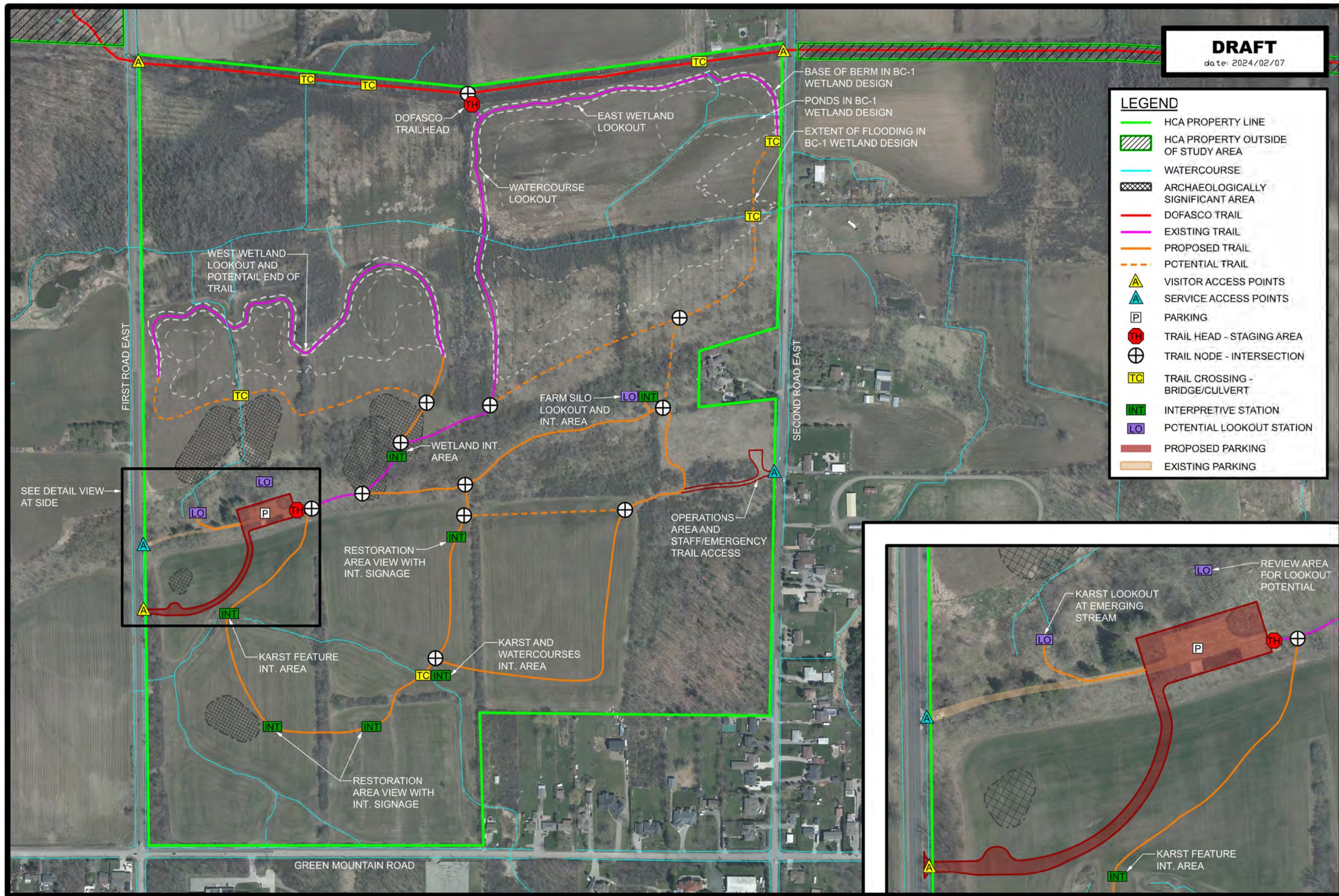


DRAFT
date: 2024/02/07



LEGEND

- HCA PROPERTY LINE
- HCA PROPERTY OUTSIDE OF STUDY AREA
- WATERCOURSE
- ARCHAEOLOGICALLY SIGNIFICANT AREA
- DOFASCO TRAIL
- EXISTING TRAIL
- PROPOSED TRAIL
- POTENTIAL TRAIL
- ▲ VISITOR ACCESS POINTS
- ▲ SERVICE ACCESS POINTS
- P PARKING
- TH TRAIL HEAD - STAGING AREA
- + TRAIL NODE - INTERSECTION
- TC TRAIL CROSSING - BRIDGE/CULVERT
- INT INTERPRETIVE STATION
- LO POTENTIAL LOOKOUT STATION
- PROPOSED PARKING
- EXISTING PARKING

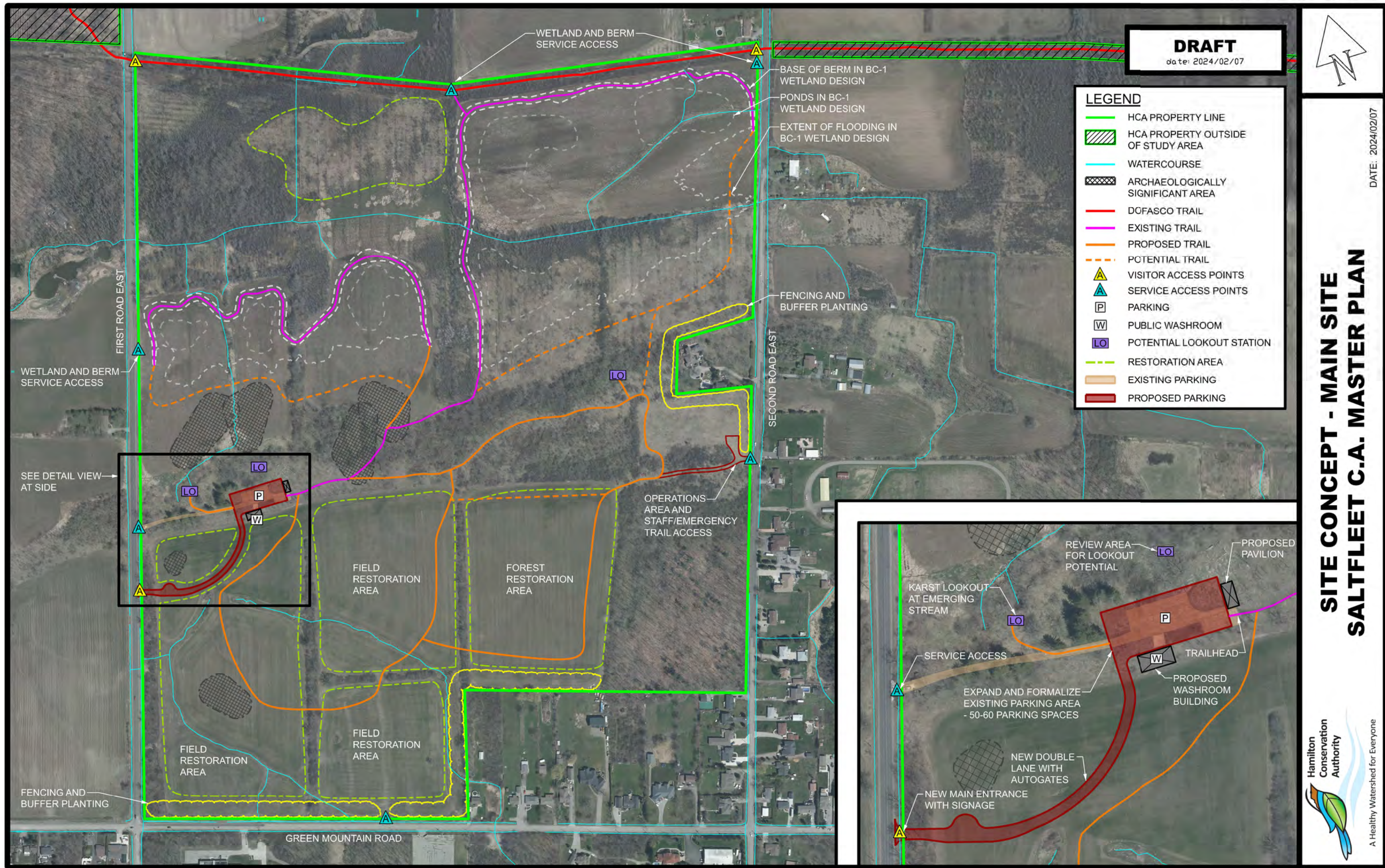


**TRAILS MASTER PLAN
SALTFLEET C.A. MASTER PLAN**

DATE: 2024/02/07



A Healthy Watershed for Everyone



DRAFT
date: 2024/02/07

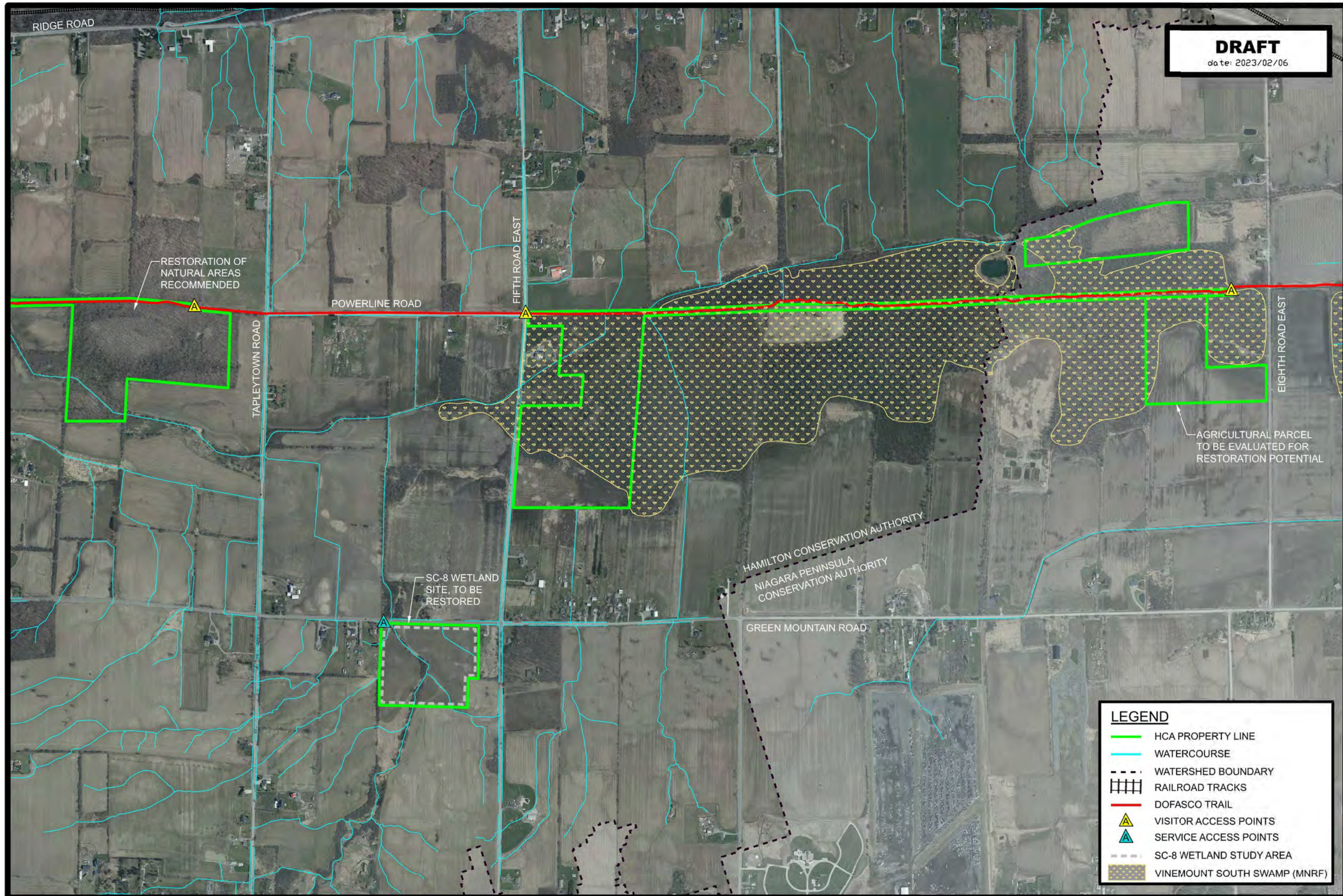
LEGEND

- HCA PROPERTY LINE
- HCA PROPERTY OUTSIDE OF STUDY AREA
- WATERCOURSE
- ARCHAEOLOGICALLY SIGNIFICANT AREA
- DOFASCO TRAIL
- EXISTING TRAIL
- PROPOSED TRAIL
- POTENTIAL TRAIL
- ▲ VISITOR ACCESS POINTS
- ▲ SERVICE ACCESS POINTS
- P PARKING
- W PUBLIC WASHROOM
- LO POTENTIAL LOOKOUT STATION
- RESTORATION AREA
- EXISTING PARKING
- PROPOSED PARKING

**SITE CONCEPT - MAIN SITE
SALTFLEET C.A. MASTER PLAN**

DATE: 2024/02/07





DRAFT
date: 2023/02/06



DATE: 2023/02/06

**SITE CONCEPT - SATELLITE SITES
SALTFLEET C.A. MASTER PLAN**

LEGEND

- HCA PROPERTY LINE
- WATERCOURSE
- - - WATERSHED BOUNDARY
- RAILROAD TRACKS
- DOFASCO TRAIL
- VISITOR ACCESS POINTS
- SERVICE ACCESS POINTS
- - - SC-8 WETLAND STUDY AREA
- VINEMOUNT SOUTH SWAMP (MNRF)

Hamilton
Conservation
Authority



A Healthy Watershed for Everyone

This page intentionally left blank.

Capital Development Priorities

DRAFT - SALTFLEET CAPITAL DEVELOPMENT PRIORITIES: 2022 - 2032**A. Site Concept Improvements *Budget (1.81M)**

A1	New Entrance Road and Parking Lot	\$ 100,000
A2	Parking Lot Automated Gates	\$ 50,000
A3**	Public Washrooms	\$ 750,000
A4	Service Access and Operation Areas	\$ 25,000
A5	Multi-Use Trails & Wayfinding Signage	\$ 400,000
A6	Open Air Structures – Trail Kiosks, Pavilion	\$ 300,000
A7	Entrance Signage	\$ 15,000
A8	Interpretive Signage	\$ 15,000
A9	Lookout Stations	\$ 150,000

B. Conservation Area Improvements *Budget (890K)

B1	Perimeter Fencing	\$ 25,000
B2	Perimeter Service Gates	\$ 10,000
B3	Vegetated Buffers	\$ 200,000
B4+	Agricultural Fields Naturalization	\$ 250,000
B5+	Natural Areas Restoration	\$ 100,000
B6+	BC-1 Wetland Establishment	\$ 50,000
B7+	Invasive Species Management	\$ 200,000
B8	Site Signage	\$ 15,000
B9	Site Furnishings	\$ 40,000

C. Outside Funding Dependent Improvements *Budget (2.10M)

C1	SC-8 Wetland Development	\$2,100,000
----	--------------------------	-------------

* Budget costs are in 2022 dollars, projects and budgets to be reviewed annually.

** Dependent on site servicing studies.

+ Costs subject to ecological findings and recommendations.

APPENDIX 3

Estimated Revenue and Expenses

Saltfleet Conservation Area Annual Operation: Estimated Revenues and Expenses*

Operation Revenues	Amount	% of Revenues
Admissions (Auto Gate, Passes)	\$ 55,000	92 %
Miscellaneous+	\$ 5,000	8 %
Total Revenues	\$ 60,000	100%

Operation Expenses	Amount	% of Expenses
Salaries – Wages and Benefits	\$ 26,400	44 %
Equipment	\$ 12,600	21 %
Taxes	\$ 7,800	13 %
Office	\$ 6,000	10 %
Materials and Supplies	\$ 2,400	4 %
Maintenance	\$ 1,800	3 %
Contracts	\$ 1,800	3 %
Utilities	\$ 1,200	2%
Total Expenses	\$ 60,000	100%

*Based on East Hamilton Mountain Operation Revenue and Expenses for 2020 and 2021. Average annual revenue and costs estimated for the life of this Master plan, with a 40 to 50-car paid parking lot.

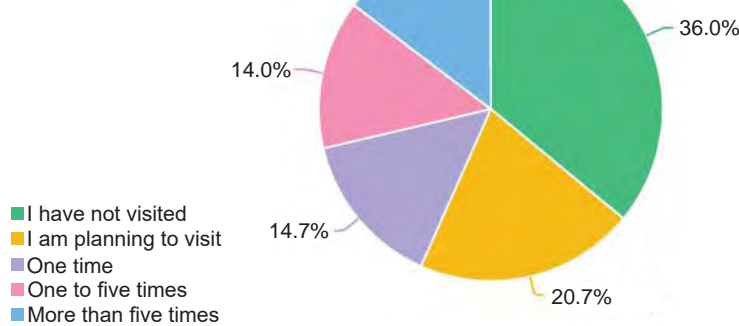
+ Miscellaneous revenues include ticketed events and tours.

APPENDIX 4

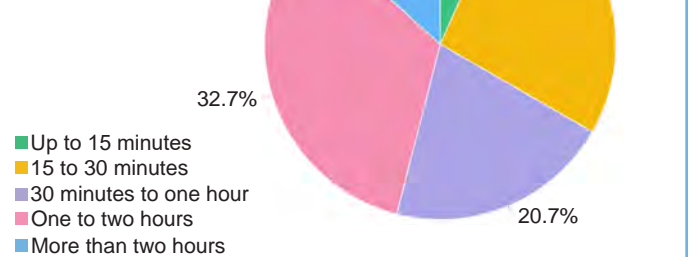
Public Survey Results

Saltfleet Survey Results Summary

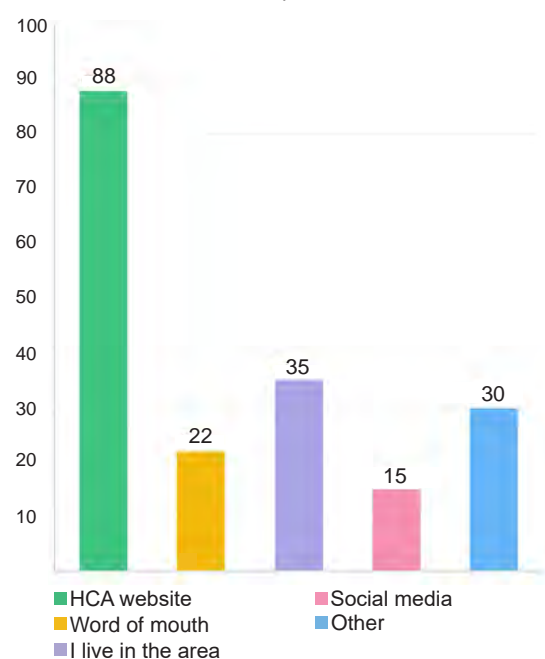
How many times have you visited Saltfleet Conservation Area?



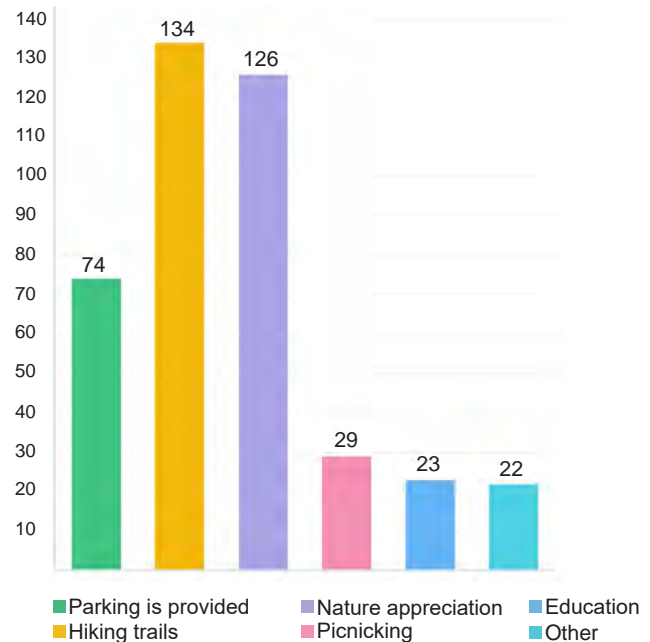
How much time would you take to travel and visit at the conservation area?



How did you learn about Saltfleet Conservation Area? (Choose all that apply)



Why do you visit conservation areas like Saltfleet? (Choose all that apply)



How else did you hear about Saltfleet Conservation Area?

- Signs along the Dofasco Trail
- Coverage in local newspaper
- Through this survey
- HCA email list

What topics would you like to see addressed with interpretive signage?

- The new wetlands
- Geological features
- Local plants and wildlife
- History of the area
- Hydrology and watercourses
- Archaeological features

Do you have any comments or suggestions for us for Saltfleet Conservation Area?

- Provide more trails
- Bird watching events
- Cycling tours
- Educational events
- Community plantings
- Seasonal events
- Bicycle racks
- Electric vehicle charging stations
- Washrooms
- Stroller friendly/accessible trails
- Garbage and recycling facilities
- Educational tours for families
- Rest stops, benches and tables

APPENDIX 5

Managed Forest Plan

6.5 Vinemount Swamp

This swamp forest is the biggest natural forest area south of the Escarpment in the City of Hamilton. Because the Vinemount Swamp is a headwaters swamp, it serves an important purpose in regulating the stream flow in Forty Mile Creek and Stoney Creek. It is home to several locally rare bird species including the Northern Harrier, Sedge Wren and Upland Sandpiper. It also serves as a stopover for many species of migratory waterfowl and supports numerous locally rare plant species. The Vinemount Swamp is visible from the current on-road section of the Dofasco 2000 Trail and its boardwalk through the swamp. *Source: <https://conservationhamilton.ca/vinemount-wetland/>*

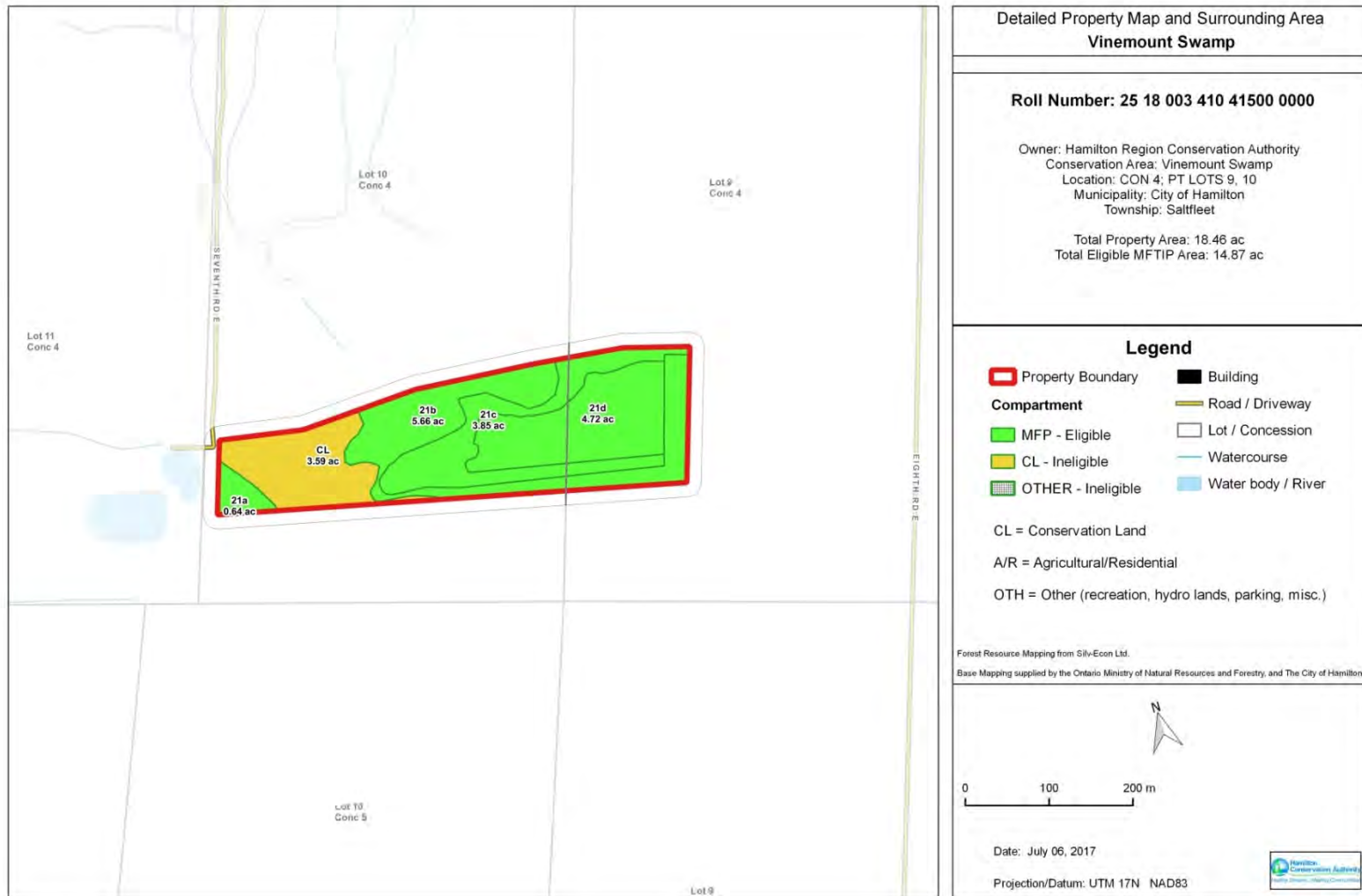
Managed Forest Summary

Roll Number (5-digit)	Forest Type 1	Area 1 (ac)	Total Area (ac)
41500	Lowland Hardwoods	14.87	14.87

Other Vegetation Observed	Invasive Species Observed	Wildlife Habitat Features			
		Snags	Cavities	Coarse Woody Debris	Mast Species
Red osier dogwood	European honeysuckle	Abundant	None observed	Few	White oak

Forest Inventory										
Comp	Area (ac)	Forest Type	Trees ≥ 10 cm DBH						Regeneration (advanced > 1m)	
			Species Composition ¹	Age (yrs)	Height (m)	Avg. DBH ² (cm)	Density (stems/ha)	Basal Area ³ (m2/ha)	Species Composition	Density (stems/ha)
21a	0.64	Lowland Hardwoods	Ag4 Ab3 Ms2	45	17	17	833	18	none	0
21b	5.66	Lowland Hardwoods	Ag4 Ms2 Ow2 Ab1 (El)1	42	21	20	654	23	Bt8 Ag2	2500
21c	3.85	Lowland Hardwoods	Ab10	20	12	10	739	8	Sng8 Ab2	4000
21d	4.72	Lowland Hardwoods	Ab10	8	14	6	65	1	Ab7 Sng3	1500

Detailed Property Maps



6.9 East Mountain Conservation Area

The East Mountain Conservation Area is predominately comprised of green ash and bur oak lowland forest, shrub habitat and vacant agricultural land. The managed forest is drained by Battlefield and Stoney Creeks, which are connected to the Provincially Significant Vinemount Swamp Wetland. Significant species include Eastern wood pewee, Wood thrush and Barn swallow. Other records include Snapping turtle, Eastern milksnake and Monarch butterfly. The property is located within a broader, landscape scale natural heritage system identified by the City of Hamilton that extends from the headwaters of Stoney and Battlefield Creeks to the Escarpment and downstream to Lake Ontario Over the years the project area has been impacted through agricultural practices and residential development. These impacts have led to the loss of wetland habitat, species biodiversity and habitat fragmentation. *Source: Communication with HCA staff.*

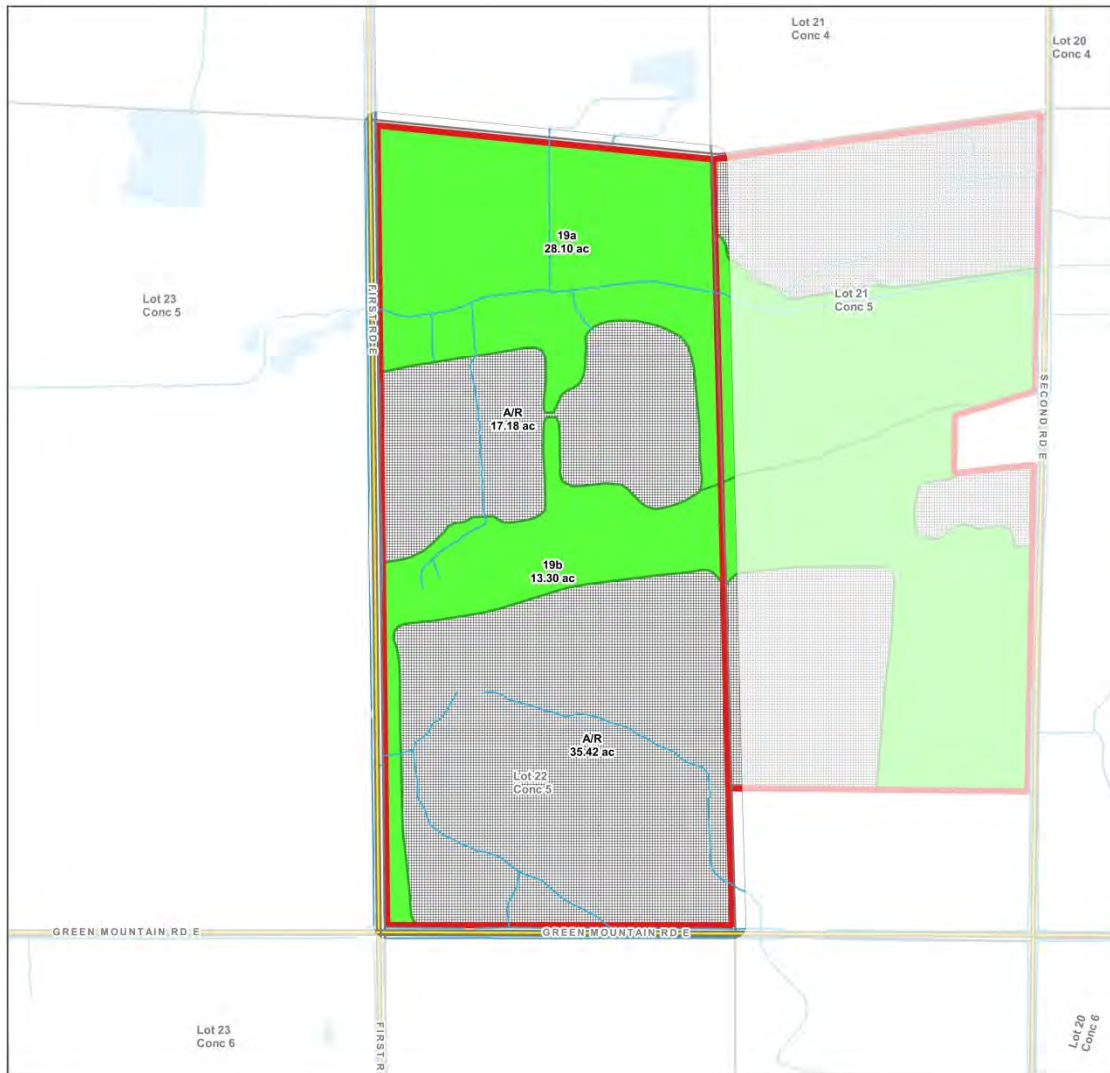
Managed Forest Summary

Roll Number (5-digit)	Forest Type 1	Area 1 (ac)	Forest Type 2	Area 2 (ac)	Total Area (ac)
71800	Lowland Hardwoods	41.40			41.40
72000	Lowland Hardwoods	18.78	Upland Hardwoods	23.49	42.27

Other Vegetation Observed	Invasive Species Observed	Wildlife Habitat Features			
		Snags	Cavities	Coarse Woody Debris	Mast Species
Speckled alder Wild rose	European honeysuckle Buckthorn	Few	Few	Few	Hickory Walnut Red oak White oak

Forest Inventory										
Comp	Area (ac)	Forest Type	Trees ≥ 10 cm DBH						Regeneration (advanced > 1m)	
			Species Composition ¹	Age (yrs)	Height (m)	Avg. DBH ² (cm)	Density (stems/ha)	Basal Area ³ (m ² /ha)	Species Composition	Density (stems/ha)
19a	28.10	Lowland Hardwoods	Ag4 Ab3 Haw1 Ow1 Wn1	32	14	11	799	12.4	Bt6 Ab2 Ag1	1600
19b	13.30	Lowland Hardwoods	Ag3 Wn3 Haw2 Mh2 (Ow)	90	19	17	753	22	none	0
19c	18.78	Lowland Hardwoods	Ab5 Hi5	28	14	8	138	2	Bt10	3000
19d	23.49	Upland Hardwoods	Mh2 Wn2 Ag1 Ap1 Cb1 lw1 Pw1 (Bd Be Haw Hi Or)1	34	21	12	493	16.5	Bt8 Mh2	1250

Detailed Property Maps



**Detailed Property Map and Surrounding Area
East Mountain**

Roll Number: 25 18 003 510 71800 0000

Owner: Hamilton Region Conservation Authority
 Conservation Area: East Mountain
 Location: CON 5; LOT 22
 Municipality: City of Hamilton
 Township: Saltfleet

Total Property Area: 94.00 ac
 Total Eligible MFTIP Area: 41.40 ac

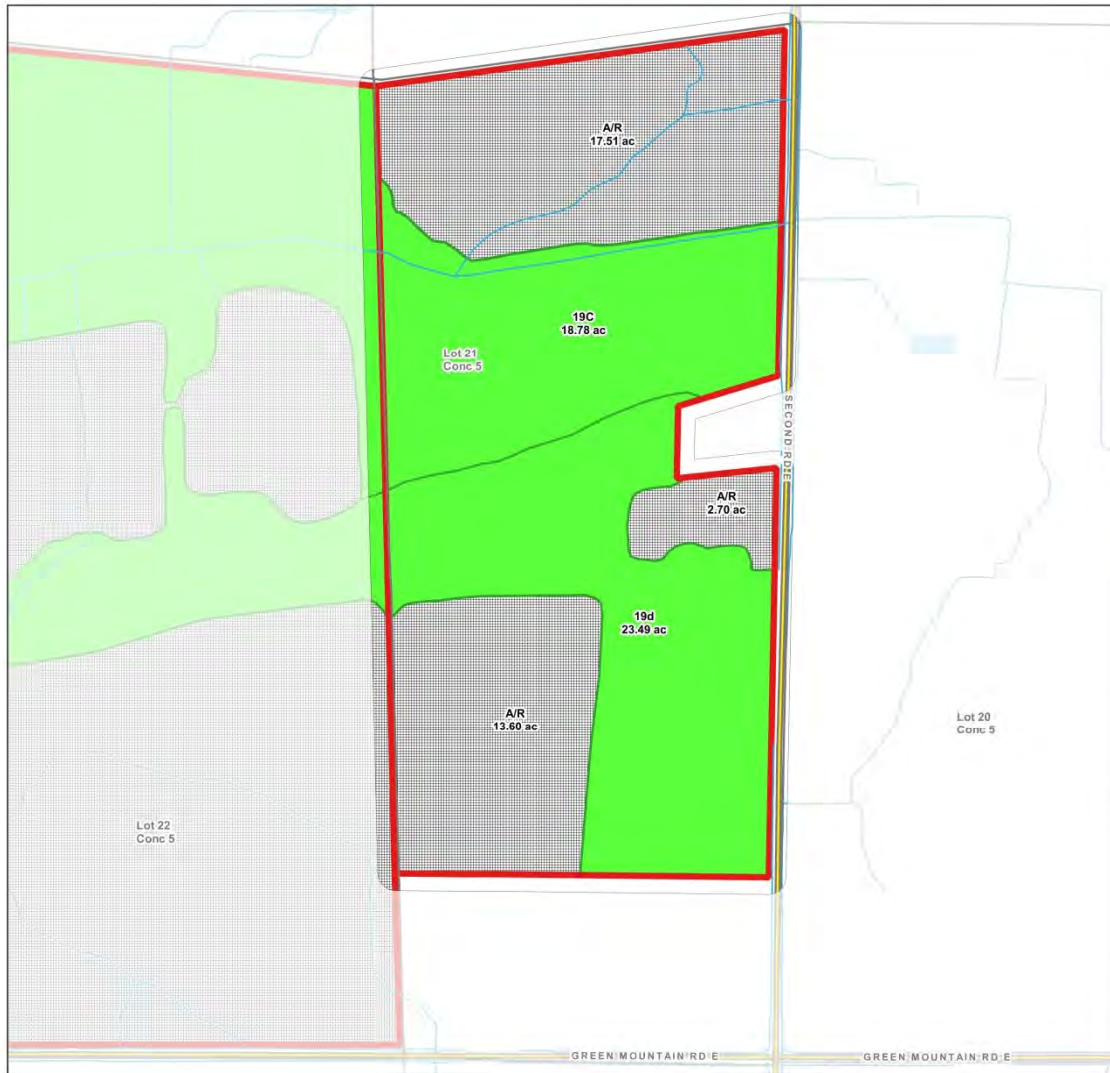
Legend

Property Boundary	Building
Compartment	Road / Driveway
MFP - Eligible	Lot / Concession
CL - Ineligible	Watercourse
OTHER - Ineligible	Water body / River

CL = Conservation Land
 A/R = Agricultural/Residential
 OTH = Other (recreation, hydro lands, parking, misc.)

Forest Resource Mapping from Silv-Econ Ltd.
 Base Mapping supplied by the Ontario Ministry of Natural Resources and Forestry, and The City of Hamilton

Date: July 06, 2017
 Projection/Datum: UTM 17N NAD83



**Detailed Property Map and Surrounding Area
East Mountain**

Roll Number: 25 18 003 510 72000 0000

Owner: Hamilton Region Conservation Authority
 Conservation Area: East Mountain
 Location: CON 5; PT LOT 21
 Municipality: City of Hamilton
 Township: Saltfleet

Total Property Area: 76.08 ac
 Total Eligible MFTIP Area: 42.27 ac

Legend

Property Boundary	Building
Compartment	Road / Driveway
MFP - Eligible	Lot / Concession
CL - Ineligible	Watercourse
OTHER - Ineligible	Water body / River

CL = Conservation Land
 A/R = Agricultural/Residential
 OTH = Other (recreation, hydro lands, parking, misc.)

Forest Resource Mapping from Silv-Econ Ltd.
 Base Mapping supplied by the Ontario Ministry of Natural Resources and Forestry, and The City of Hamilton

Date: July 06, 2017
 Projection/Datum: UTM 17N NAD83

Section 7 : Ten Year Activity Summary 2018-2027

The following management activities are recommended for the 2018-2027 operating period.

Forest Health & Ecological Diversity

Control Invasive plants

- The Ontario Invasive Plant Council recommends creating a feasible, long-term strategy for managing invasive species. Many of the managed forest compartments have been colonized by buckthorn and other invasive plant species. Buckthorn is particularly problematic because it is the dominant species in the regeneration of a number of the compartments. Managing the buckthorn is an important silvicultural objective in maintaining a healthy and productive forest.

Manage Red Pine Decline

- A number of the red pine plantations are declining as a result of root diseases. The HCA has been thinning these plantations to mitigate the effects of the decline in the overstory and promote natural regeneration. Many of the plantations also lack desirable regeneration and some are heavily colonized by buckthorn. Controlling the buckthorn and restoring regeneration through underplanting is highly recommended.

Monitor Invasive Insects

- Many, if not all, of the mature ash in the managed forest have been affected by Emerald Ash Borer. Fortunately ash is commonly found in the regeneration of many stands and it is unlikely that ash species will disappear from the managed forest.
- Hemlock stands are at risk from Hemlock woolly adelgid (HWA). Hemlock is dominant/co-dominant in Fletcher compartment 1f and Beverly Swamp compartment 4b and is a minor species in several other compartments. These stands should be monitored for signs of HWA and report infected stands to the Canadian Food Inspection Agency (CFIA). Silv-Econ is coordinating a working group of forest managers/owners who have hemlock stands on their properties. The HCA may wish to participate in this working group.

Wildlife & Nature Appreciation

Conserve Habitat Features

- Wildlife habitats can be conserved or enhanced by retaining snags, fallen trees and logs, and trees with cavities.
- Mitigating the impacts from management activities on Species At Risk and other wildlife may require modifications to conventional silvicultural activities, establishing buffers around critical habitat, and seasonal restrictions for undertaking management activities, among other mitigation measures.

Recreation

- There is an extensive network of recreational trails throughout most of the managed forest. Maintaining the trails by trimming vegetation, removing fallen logs and hazard trees, and making repairs when required is recommended.

Forest Products

- A second thinning of the conifer plantations at Christie, Dundas Valley, Mt. Albion, Valens, and Westfield Heritage Village can be considered during the 2018-2027 operating period.
- There are approximately 115 acres of conifer plantations at Fletcher Creek that could also be considered for thinning during the 2018-2027 operating period.

Section 11 : Tree Species & Species Abbreviations

Abbreviation	Species	Abbreviation	Species
Ag	green ash	Mst	Striped maple
Ap	apple	Nb	Nannyberry
Aw	white ash	Ob	bur oak
Bd	basswood	OC	other conifers
Be	American beech	OH	other hardwood
Bf	balsam fir	Or	red oak
Bn	butternut	Ow	white oak
Bt	European buckthorn	Pa	Austrian pine
Bw	white birch	Pb	balsam poplar
By	yellow birch	Pg	large tooth aspen
Cb	black cherry	Ph	hybrid poplar
Cc	choke cherry	Pj	jack pine
Ce	white cedar	Po	poplar species
El	elm	Pr	red pine
Ha	hawthorn	Ps	Scots pine
Hac	hackberry	Pt	trembling aspen
He	eastern hemlock	Pw	white pine
Hi	bitternut hickory	Sas	sassafras
Hs	shagbark hickory	Sb	black spruce
Iw	ironwood	Sc	blue spruce
La	European larch	Sn	Norway spruce
Lb	black locust	Sw	white spruce
Lh	Honey locust	Syc	American sycamore
Mash	mountain ash	Ta	tamarack
Mb	black maple	Tu	tulip tree
Mh	sugar maple	Wi	willow
Mm	Manitoba maple	Wn	black walnut
Mr	red maple		
Ms	silver maple		

APPENDIX 6

Natural Areas Inventory – Species List and References

Species, BC-1 Property

Appendix 6.1 Vascular Plants

Appendix 6.2 Birds

Appendix 6.3 Mammals

Appendix 6.4 Butterflies

Appendix 6.5 Dragonflies and Damselflies

Appendix 6.6 Reptiles and Amphibians

Appendix 6.7 Fish

Species, SC-8 Property

Appendix 6.8 Vascular Plants

Appendix 6.9 Birds

Appendix 6.10 Mammals

Appendix 6.11 Butterflies

Appendix 6.12 Dragonflies and Damselflies

Appendix 6.13 Reptiles and Amphibians

Appendix 6.14 Fish

Species, Vinemount Swamp

Appendix 6.15 Plants

Appendix 6.16 Birds

Appendix 6.17 Mammals

Appendix 6.18 Butterflies and Dragonflies

Species, Tapleystown Woods

Appendix 6.19 Plants

Appendix 6.20 Birds

Appendix 6.21 Mammals

Appendix 6.22 Butterflies

Vascular Plant Species Reported From the Study Area, BC-1

Scientific Name	Common Name	CC	CW	Weed	SRANK ¹	SARO ²	COSEWIC ³	SARA Schedule ³	Hamilton Status ⁴	MNRF SAR List ⁵	NHIC Data ⁶	NRSI Observed
Pteridophytes												
Ferns & Allies												
Dryopteridaceae												
Wood Fern Family												
<i>Dryopteris carthusiana</i>	Spinulose Wood Fern	5	-2		S5				X			X
<i>Onoclea sensibilis</i>	Sensitive Fern	4	-3		S5				X			X
Equisetaceae												
Horsetail Family												
<i>Equisetum arvense</i>	Field Horsetail	0	0		S5				X			X
Thelypteridaceae												
Beech Fern Family												
<i>Phegopteris hexagonoptera</i>	Broadbeech Fern	9	1		S3	SC	SC	Schedule 3	R5	X		
Gymnosperms												
Conifers												
Cupressaceae												
Cypress Family												
<i>Juniperus virginiana</i>	Eastern Red Cedar	4	3		S5				X			X
Pinaceae												
Pine Family												
<i>Picea abies</i>	Norway Spruce		5	-1	SE3				I			X
<i>Picea glauca</i>	White Spruce	6	3		S5				X			X
<i>Pinus resinosa</i>	Red Pine	8	3		S5				X			X
Dicotyledons												
Dicots												
Aceraceae												
Maple Family												
<i>Acer negundo</i>	Manitoba Maple	0	-2		S5				X			X
<i>Acer rubrum</i>	Red Maple	4	0		S5				X			X
<i>Acer saccharum ssp. saccharum</i>	Sugar Maple	4	3		S5				X			X
<i>Acer saccharum ssp. nigrum</i>	Black Maple	7	3		S4?				X			X
Anacardiaceae												
Sumac or Cashew Family												
<i>Rhus hirta</i>	Staghorn Sumac	1	5		S5				X			X
<i>Toxicodendron rydbergii</i>	Poison-ivy	0	0		S5				X			X
Apiaceae												
Carrot or Parsley Family												
<i>Anthriscus sylvestris</i>	Woodland Chervil		5	-2	SE4?							X
<i>Daucus carota</i>	Wild Carrot		5	-2	SE5				I			X
Araliaceae												
Ginseng Family												
<i>Panax quinquefolius</i>	Ginseng	9	5		S3	END	E	Schedule 1	R2	X		
Asclepiadaceae												
Milkweed Family												
<i>Asclepias incarnata ssp. incarnata</i>	Swamp Milkweed	6	-5		S5				X			X
<i>Asclepias syriaca</i>	Common Milkweed	0	5		S5				X			X
Asteraceae												
Composite or Aster Family												
<i>Ambrosia artemisiifolia</i>	Common Ragweed	0	3		S5				X			X

Vascular Plant Species Reported From the Study Area, BC-1 (cont.)

Scientific Name	Common Name	CC	CW	Weed	SRANK ¹	SARO ²	COSEWIC ³	SARA Schedule ³	Hamilton Status ⁴	MNRF SAR List ⁵	NHIC Data ⁶	NRSI Observed
<i>Arctium minus ssp. minus</i>	Common Burdock		5	-2	SE5				I			X
<i>Cirsium arvense</i>	Canada Thistle		3	-1	SE5				I			X
<i>Cirsium vulgare</i>	Bull Thistle		4	-1	SE5				I			X
<i>Erigeron annuus</i>	Daisy Fleabane	0	1		S5				X			X
<i>Erigeron philadelphicus ssp. philadelphicus</i>	Philadelphia Fleabane	1	-3		S5				X			X
<i>Eurybia divaricata</i>	White Wood Aster	10	5		S2	THR	T	Schedule 1	R1	X		
<i>Euthamia graminifolia</i>	Flat-topped Bushy Goldenrod	2	-2		S5				X			X
<i>Hieracium caespitosum ssp. caespitosum</i>	Field Hawkweed		5	-2	SE5				I			X
<i>Hymenoxys herbacea</i>	Lakeside Daisy	10	5		S3	THR	T	Schedule 1		X		
<i>Leucanthemum vulgare</i>	Ox-eye Daisy		5	-1	SE5				I			X
<i>Matricaria discoidea</i>	Pineapple-weed				SE5				I			X
<i>Rudbeckia triloba</i>	Brown-eyed Coneflower		1	-1	SE4				I			X
<i>Solidago altissima var. altissima</i>	Tall Goldenrod	1	3		S5				X			X
<i>Solidago canadensis</i>	Canada Goldenrod	1	3		S5				X			X
<i>Solidago juncea</i>	Early Goldenrod	3	5		S5				X			X
<i>Solidago nemoralis ssp. nemoralis</i>	Gray Goldenrod	2	5		S5				X			X
<i>Sonchus arvensis ssp. arvensis</i>	Field Sow-thistle				SE5				I			X
<i>Symphotrichum ericoides var. ericoides</i>	White Heath Aster				S5				X			X
<i>Symphotrichum novae-angliae</i>	New England Aster	2	-3		S5				X			X
<i>Symphotrichum pilosum var. pilosum</i>	Hairy Aster	4	2		S5				X			X
<i>Symphotrichum urophyllum</i>	Arrow-leaved Aster	6	5		S4				X			X
<i>Taraxacum officinale</i>	Common Dandelion		3	-2	SE5				I			X
Balsaminaceae		Touch-me-not Family										
<i>Impatiens capensis</i>	Spotted Touch-me-not	4	-3		S5				X			X
Berberidaceae		Barberry Family										
<i>Podophyllum peltatum</i>	May-apple	5	3		S5				X			X
Betulaceae		Birch Family										
<i>Betula lenta</i>	Cherry Birch	9	3		S1	END	E	Schedule 1		X		
<i>Carpinus caroliniana ssp. virginiana</i>	Blue Beech	6	0		S5				X			X
<i>Ostrya virginiana</i>	Hop Hornbeam	4	4		S5				X			X
Brassicaceae		Mustard Family										
<i>Alliaria petiolata</i>	Garlic Mustard		0	-3	SE5				I			X
<i>Hesperis matronalis</i>	Dame's Rocket		5	-3	SE5				I			X
Caprifoliaceae		Honeysuckle Family										
<i>Lonicera dioica</i>	Glaucous Honeysuckle	5	3		S5				X			X
<i>Lonicera tatarica</i>	Tartarian Honeysuckle		3	-3	SE5				I			X
<i>Viburnum lentago</i>	Nannyberry	4	-1		S5				X			X
Celastraceae		Staff-tree Family										
<i>Euonymus obovata</i>	Running Strawberry-bush	6	5		S5				X			X

Vascular Plant Species Reported From the Study Area, BC-1 (cont.)

Scientific Name	Common Name	CC	CW	Weed	SRANK ¹	SARO ²	COSEWIC ³	SARA Schedule ³	Hamilton Status ⁴	MNRF SAR List ⁵	NHIC Data ⁶	NRSI Observed
Cornaceae		Dogwood Family										
<i>Cornus florida</i>	Eastern Flowering Dogwood	7	4		S2?	END	E	Schedule 1	X	X	X	
<i>Cornus foemina ssp. racemosa</i>	Red Panicked Dogwood	2	-2		S5				X			X
Dipsacaceae		Teasel Family										
<i>Dipsacus fullonum ssp. sylvestris</i>	Wild Teasel		5	-1	SE5				I			X
Elaeagnaceae		Oleaster Family										
<i>Elaeagnus umbellata</i>	Autumn Olive		3	-3	SE3				I			X
Euphorbiaceae		Spurge Family										
<i>Acalypha virginica var. rhomboidea</i>	Three-seeded Mercury	0	3		S5				X			X
Fabaceae		Pea Family										
<i>Gymnocladus dioicus</i>	Kentucky Coffee-tree	6	5		S2	THR	T	Schedule 1	I	X		
<i>Lotus corniculatus</i>	Bird's-foot Trefoil		1	-2	SE5				I			X
<i>Medicago lupulina</i>	Black Medick		1	-1	SE5				I			X
<i>Melilotus officinalis</i>	Yellow Sweet-clover		3	-1	SE5				I			X
<i>Trifolium pratense</i>	Red Clover		2	-2	SE5				I			X
<i>Trifolium repens</i>	White Clover		2	-1	SE5				I			X
<i>Vicia cracca</i>	Tufted Vetch		5	-1	SE5				I			X
Fagaceae		Beech Family										
<i>Castanea dentata</i>	American Chestnut	8	5		S2	END	E	Schedule 1	U	X		
<i>Fagus grandifolia</i>	American Beech	6	3		S5				X			X
<i>Quercus alba</i>	White Oak	6	3		S5				X			X
<i>Quercus macrocarpa</i>	Bur Oak	5	1		S5				X			X
<i>Quercus rubra</i>	Red Oak	6	3		S5				X			X
Gentianaceae		Gentian Family										
<i>Frasera caroliniensis</i>	American Columbo	10	5		S2	END	E	Schedule 1	R1	X		
Geraniaceae		Geranium Family										
<i>Geranium maculatum</i>	Spotted Crane's-bill	6	3		S5				X			X
<i>Geranium robertianum</i>	Herb Robert		5	-2	SE5				I			X
Guttiferae		St. John's-wort Family										
<i>Hypericum perforatum</i>	Common St. John's-wort		5	-3	SE5				I			X
Hydrophyllaceae		Water-leaf Family										
<i>Hydrophyllum virginianum</i>	Virginia Water-leaf	6	-2		S5				X			X
Juglandaceae		Walnut Family										
<i>Carya cordiformis</i>	Bitternut Hickory	6	0		S5				X			X
<i>Carya ovata var. ovata</i>	Shagbark Hickory	6	3		S5				X			X
<i>Juglans cinerea</i>	Butternut	6	2		S2?	END	E	Schedule 1	X	X		

Vascular Plant Species Reported From the Study Area, BC-1 (cont.)

Scientific Name	Common Name	CC	CW	Weed	SRANK ¹	SARO ²	COSEWIC ³	SARA Schedule ³	Hamilton Status ⁴	MNRF SAR List ⁵	NHIC Data ⁶	NRSI Observed
<i>Juglans nigra</i>	Black Walnut	5	3		S4				X			X
Lamiaceae		Mint Family										
<i>Lamium purpureum</i>	Purple Dead-nettle		5	-2	SE3				I			X
<i>Lycopus uniflorus</i>	Northern Water-horehound	5	-5		S5				X			X
<i>Pycnanthemum incanum</i> var. <i>incanum</i>	Hoary Mountain-mint	10	5		S1	END	E	Schedule 1	R1	X		
Limnanthaceae		False Mermaid Family										
<i>Floerkea proserpinacoides</i>	False Mermaid	9	-1		S4		NAR		U			X
Lythraceae		Loosestrife Family										
<i>Lythrum salicaria</i>	Purple Loosestrife		-5	-3	SE5				I			X
Magnoliaceae		Magnolia Family										
<i>Magnolia acuminata</i>	Cucumber Tree	10	1		S2	END	E	Schedule 1		X		
Moraceae		Mulberry Family										
<i>Morus alba</i>	White Mulberry		0	-3	SE5				I			X
<i>Morus rubra</i>	Red Mulberry	10	1		S2	END	E	Schedule 1	R4	X		
Oleaceae		Olive Family										
<i>Fraxinus americana</i>	White Ash	4	3		S5				X			X
<i>Fraxinus pennsylvanica</i>	Green Ash	3	-3		S5				X			X
<i>Ligustrum vulgare</i>	Common Privet		1	-2	SE5				I			X
<i>Syringa vulgaris</i>	Common Lilac		5	-2	SE5				I			X
Onagraceae		Evening-primrose Family										
<i>Circaea lutetiana</i> ssp. <i>canadensis</i>	Yellowish Enchanter's Nightshade	3	3		S5				X			X
<i>Epilobium hirsutum</i>	Great Hairy Willow-herb		-4	-2	SE5				I			X
<i>Oenothera biennis</i>	Common Evening-primrose	0	3		S5				X			X
Papaveraceae		Poppy Family										
<i>Chelidonium majus</i>	Celandine		5	-3	SE5				I			X
<i>Sanguinaria canadensis</i>	Bloodroot	5	4		S5				X			X
Plantaginaceae		Plantain Family										
<i>Plantago major</i>	Common Plantain		-1	-1	SE5				I			X
Polygonaceae		Smartweed Family										
<i>Polygonum persicaria</i>	Lady's-thumb		-3	-1	SE5				I			X
<i>Rumex crispus</i>	Curly-leaf Dock		-1	-2	SE5				I			X
Portulacaceae		Purslane Family										
<i>Claytonia virginica</i>	Virginia Spring Beauty	5	3		S5				X			X
Ranunculaceae		Buttercup Family										

Vascular Plant Species Reported From the Study Area, BC-1 (cont.)

Scientific Name	Common Name	CC	CW	Weed	SRANK ¹	SARO ²	COSEWIC ³	SARA Schedule ³	Hamilton Status ⁴	MNRF SAR List ⁵	NHIC Data ⁶	NRSI Observed
<i>Ranunculus abortivus</i>	Kidney-leaf Buttercup	2	-2		S5				X			X
Rhamnaceae		Buckthorn Family										
<i>Rhamnus cathartica</i>	European Buckthorn		3	-3	SE5				I			X
<i>Frangula alnus</i>	Glossy Buckthorn		-1	-3	SE5				I			X
Rosaceae		Rose Family										
<i>Agrimonia gryposepala</i>	Tall Hairy Agrimony	2	2		S5							X
<i>Amelanchier arborea</i>	Downy Juneberry		3		S5				X			X
<i>Crataegus species</i>	Hawthorn species											X
<i>Fragaria virginiana</i>	Wild Strawberry				S5							X
<i>Geum laciniatum</i>	Rough Avens		-3		S4				X			X
<i>Malus domestica</i>	Apple											X
<i>Potentilla recta</i>	Rough-fruited Cinquefoil		5	-2	SE5				I			X
<i>Prunus avium</i>	Cherry Plum		5	-2	SE4				I			X
<i>Prunus virginiana ssp. virginiana</i>	Choke Cherry	2	1		S5				X			X
<i>Pyrus communis</i>	Common Pear		5	-1	SE4				I			X
<i>Rosa multiflora</i>	Multiflora Rose		3	-3	SE4				I			X
<i>Rubus occidentalis</i>	Black Raspberry	2	5		S5				X			X
Rubiaceae		Madder Family										
<i>Galium aparine</i>	Cleavers	4	3		S5				X			X
Rutaceae		Rue Family										
<i>Ptelea trifoliata</i>	Common Hop-tree	9	2		S3	SC	T	Schedule 1	I	X		
<i>Zanthoxylum americanum</i>	American Prickly-ash	3	5		S5				X			X
Scrophulariaceae		Figwort Family										
<i>Verbascum thapsus</i>	Common Mullein		5	-2	SE5				I			X
<i>Veronica officinalis</i>	Common Speedwell		5	-2	SE5				I			X
Solanaceae		Nightshade Family										
<i>Solanum dulcamara</i>	Bitter Nightshade		0	-2	SE5				I			X
Tiliaceae		Linden Family										
<i>Tilia americana</i>	American Basswood	4	3		S5				X			X
Ulmaceae		Elm Family										
<i>Ulmus americana</i>	White Elm	3	-2		S5				X			X
<i>Ulmus rubra</i>	Slippery Elm	6	0		S5				X			X
Verbenaceae		Vervain Family										
<i>Verbena urticifolia</i>	White Vervain	4	-1		S5				X			X
Violaceae		Violet Family										
<i>Viola sororia</i>	Woolly Blue Violet	4	1		S5				X			X

Vascular Plant Species Reported From the Study Area, BC-1 (cont.)

Scientific Name	Common Name	CC	CW	Weed	SRANK ¹	SARO ²	COSEWIC ³	SARA Schedule ³	Hamilton Status ⁴	MNRF SAR List ⁵	NHIC Data ⁶	NRSI Observed
Vitaceae		Grape Family										
<i>Parthenocissus vitacea</i>	Woodbine	3	3		S5				X			X
<i>Vitis riparia</i>	Riverbank Grape	0	-2		S5				X			X
Monocotyledons		Monocots										
Araceae		Arum Family										
<i>Arisaema dracontium</i>	Green Dragon	9	-3		S3	SC	SC	Schedule 3	R5	X		
<i>Arisaema triphyllum</i>	Jack-in-the-pulpit	5	-2		S5				X			X
<i>Calla palustris</i>	Wild Calla	8	-5		S5				X			X
Cyperaceae		Sedge Family										
<i>Carex cristatella</i>	Crested Sedge	3	-4		S5				X			X
<i>Carex grisea</i>	Narrow-leaved Sedge	8	1		S4				U			X
<i>Carex lupulina</i>	Hop Sedge	6	-5		S5				X			X
<i>Carex normalis</i>	Larger Straw Sedge	6	-3		S4				X			X
<i>Carex pellita</i>	Woolly Sedge	4	-5		S5				X			X
<i>Carex pensylvanica</i>	Pennsylvania Sedge	5	5		S5				X			X
<i>Carex retrorsa</i>	Retrorse Sedge	5	-5		S5				X			X
<i>Carex stipata</i>	Awl-fruited Sedge	3	-5		S5				X			X
<i>Carex vulpinoidea</i>	Fox Sedge	3	-5		S5				X			X
<i>Scirpus cyperinus</i>	Wool-grass	4	-5		S5				X			X
<i>Trichophorum planifolium</i>	Bashful Bulrush	10	5		S1	END	E	Schedule 1		X		
Juncaceae		Rush Family										
<i>Juncus articulatus</i>	Jointed Rush	5	-5		S5				X			X
<i>Juncus tenuis</i>	Path Rush	0	0		S5				X			X
Liliaceae		Lily Family										
<i>Erythronium americanum ssp. americanum</i>	Yellow Dog's-tooth Violet	5	5		S5				X			X
<i>Hemerocallis fulva</i>	Orange Day-lily		5	-3	SE5				I			X
<i>Lilium michiganense</i>	Michigan Lily	7	-1		S5				X			X
<i>Maianthemum racemosum ssp. racemosum</i>	False Solomon's Seal	4	3		S5				X			X
<i>Narcissus pseudonarcissus</i>	Daffodil				SE2							X
<i>Scilla siberica</i>	Squill		5	-1	SE2				I			X
<i>Trillium grandiflorum</i>	White Trillium	5	5		S5				X			X
Orchidaceae		Orchid Family										
<i>Liparis loeselii</i>	Fen Twayblade	5	-4		S4S5				X			X
Poaceae		Grass Family										
<i>Agrostis stolonifera</i>	Redtop		-3		S5				X			X
<i>Bromus inermis ssp. inermis</i>	Awnless Brome		5	-3	SE5				I			X
<i>Bromus secalinus ssp. secalinus</i>	Cheat Chess		5	-1	SE4				I			X
<i>Cinna arundinacea</i>	Wood Reed Grass	7	-3		S4				X			X
<i>Dactylis glomerata</i>	Orchard Grass		3	-1	SE5				I			X

Vascular Plant Species Reported From the Study Area, BC-1 (cont.)

Scientific Name	Common Name	CC	CW	Weed	SRANK ¹	SARO ²	COSEWIC ³	SARA Schedule ³	Hamilton Status ⁴	MNRF SAR List ⁵	NHIC Data ⁶	NRSI Observed
<i>Elymus repens</i>	Quack Grass		3	-3	SE5				I			X
<i>Glyceria striata</i>	Fowl Meadow Grass	3	-5		S5				X			X
<i>Leersia virginica</i>	White Cut Grass	6	-3		S4				X			X
<i>Phalaris arundinacea</i>	Reed Canary Grass	0	-4		S5				X			X
<i>Phleum pratense</i>	Timothy		3	-1	SE5				I			X
<i>Phragmites australis ssp. australis</i>	European Common Reed				SNA				I			X
<i>Poa pratensis ssp. pratensis</i>	Kentucky Bluegrass	0	1		S5				I			X
<i>Setaria pumila</i>	Yellow Foxtail		0	-1	SE5				I			X
Typhaceae												
Cattail Family												
<i>Typha angustifolia</i>	Narrow-leaved Cattail	3	-5		S5				X			X
									Total	16	1	150

¹MNRF 2019a, ²MNRF 2019b, ³Gov. of Canada 2019, ⁴HCA 2014, ⁵NHIC 2019, ⁶MNRF 2019c

Bird Species Reported From the Study Area, BC-1

Scientific Name	Common Name	SRANK ¹	SARO ²	COSEWIC ³	SARA Schedule ³	Hamilton Status ⁴	OBBA (17PH08) ⁵	NHIC Data ⁶	MNRF SAR List ⁷	NRSI Observed
Anatidae		Ducks, Geese & Swans								
<i>Branta canadensis</i>	Canada Goose	S5				C	CO			X
<i>Cygnus olor</i>	Mute Swan	SNA				R (I)	CO			
<i>Aix sponsa</i>	Wood Duck	S5				U	CO			X
<i>Anas platyrhynchos</i>	Mallard	S5				C	CO			X
Phasianidae		Partridges, Grouse & Turkeys								
<i>Phasianus colchicus</i>	Ring-necked Pheasant	SNA				R (I)	PR			
<i>Meleagris gallopavo</i>	Wild Turkey	S5				C	CO			X
Podicipediformes		Grebes								
<i>Podiceps auritus</i>	Horned Grebe	S1B, S4N	SC	SC	No Schedule				X	
Columbidae		Pigeons & Doves								
<i>Columba livia</i>	Rock Pigeon	SNA				A	CO			X
<i>Zenaidura macroura</i>	Mourning Dove	S5				A	CO			X
Cuculiformes		Cuckoos & Anis								
<i>Coccyzus americanus</i>	Yellow-billed Cuckoo	S4B				R	PR			X
<i>Coccyzus erythrophthalmus</i>	Black-billed Cuckoo	S5B				U	PO			X
Caprimulgidae		Goatsuckers								
<i>Chordeiles minor</i>	Common Nighthawk	S4B	SC	SC	Schedule 1	R			X	X
<i>Caprimulgus vociferus</i>	Eastern Whip-poor-will	S4B	THR	T	Schedule 1	R			X	
Apodidae		Swifts								
<i>Chaetura pelagica</i>	Chimney Swift	S4B, S4N	THR	T	Schedule 1	U	PR		X	
Trochilidae		Hummingbirds								
<i>Archilochus colubris</i>	Ruby-throated Hummingbird	S5B				U	PR			
Rallidae		Rails, Gallinules & Coots								
<i>Rallus elegans</i>	King Rail	S2B	END	E	Schedule 1	EX			X	
<i>Rallus limicola</i>	Virginia Rail	S5B				U	PR			
<i>Porzana carolina</i>	Sora	S4B				U	PR			
Charadriidae		Plovers								
<i>Charadrius melodus</i>	Piping Plover	S1B	END	E	Schedule 1	EX			X	
<i>Charadrius vociferus</i>	Killdeer	S5B, S5N				A	CO			X
Scolopacidae		Waders								
<i>Bartramia longicauda</i>	Upland Sandpiper	S4B				R	CO			
<i>Calidris canutus rufa</i>	Red Knot (rufa subspecies)		END	E	No Schedule				X	
<i>Gallinago delicata</i>	Wilson's Snipe	S5B				R				X
<i>Scolopax minor</i>	American Woodcock	S4B				C	CO			X
<i>Actitis macularia</i>	Spotted Sandpiper	S5				C	CO			X
<i>Phalaropus lobatus</i>	Red-necked Phalarope	S3S4B	SC						X	

Bird Species Reported From the Study Area, BC-1 (cont.)

Scientific Name	Common Name	SRANK ¹	SARO ²	COSEWIC ³	SARA Schedule ³	Hamilton Status ⁴	OBBA (17PH08) ⁵	NHIC Data ⁶	MNRF SAR List ⁷	NRSI Observed
Laridae		Gulls, Terns & Skimmers								
<i>Larus delawarensis</i>	Ring-billed Gull	S5B, S4N				A	CO			X
<i>Larus argentatus</i>	Herring Gull	S5B, S5N				C				X
<i>Chlidonias niger</i>	Black Tern	S3B	SC	NAR		EX			X	
Phalacrocoracidae		Cormorants								
<i>Phalacrocorax auritus</i>	Double-crested Cormorant	S5B	NAR	NAR		A				X
Pelecanidae		Pelicans								
<i>Pelecanus erythrorhynchos</i>	American White Pelican	S2B	THR	NAR					X	
Ardeidae		Hérons & Bitterns								
<i>Ixobrychus exilis</i>	Least Bittern	S4B	THR	T	Schedule 1	R			X	
<i>Ardea herodias</i>	Great Blue Heron	S4B				U	PR			X
<i>Butorides virescens</i>	Green Heron	S4B				U	CO			
Cathartidae		Vultures								
<i>Cathartes aura</i>	Turkey Vulture	S5B				U	PR			X
Accipitridae		Hawks, Kites, Eagles & Allies								
<i>Haliaeetus leucocephalus</i>	Bald Eagle	S2N, S4B	SC	NAR		R			X	
<i>Circus cyaneus</i>	Northern Harrier	S4B	NAR	NAR		R	PR			
<i>Accipiter striatus</i>	Sharp-shinned Hawk	S5	NAR			R	PO			
<i>Accipiter cooperii</i>	Cooper's Hawk	S4	NAR	NAR		U	CO			X
<i>Buteo jamaicensis</i>	Red-tailed Hawk	S5	NAR	NAR		C	CO			X
Tytonidae		Barn Owls								
<i>Tyto alba</i>	Barn Owl	S1	END	E	Schedule 1	EX			X	
Strigidae		Typical Owls								
<i>Megascops asio</i>	Eastern Screech-Owl	S4	NAR	NAR		U	PO			
<i>Bubo virginianus</i>	Great Horned Owl	S4				C	CO			X
<i>Asio flammeus</i>	Short-eared Owl	S2N, S4B	SC	SC	Schedule 3	R	PR		X	
Alcedinidae		Kingfishers								
<i>Megaceryle alcyon</i>	Belted Kingfisher	S4B				U	PO			X
Picidae		Woodpeckers								
<i>Melanerpes erythrocephalus</i>	Red-headed Woodpecker	S4B	SC	END	Schedule 1	R	CO		X	
<i>Melanerpes carolinus</i>	Red-bellied Woodpecker	S4				U	CO			X
<i>Sphyrapicus varius</i>	Yellow-bellied Sapsucker	S5B				R				X
<i>Picoides pubescens</i>	Downy Woodpecker	S5				C	CO			X
<i>Picoides villosus</i>	Hairy Woodpecker	S5				U	PR			X
<i>Colaptes auratus</i>	Northern Flicker	S4B				C	CO			X
Falconidae		Caracaras & Falcons								
<i>Falco sparverius</i>	American Kestrel	S4				U	CO			X
<i>Falco columbarius</i>	Merlin	S5B	NAR	NAR		R				X
<i>Falco peregrinus anatum/tundrius</i>	Peregrine Falcon	S3B	SC	SC	Schedule 1	R			X	

Bird Species Reported From the Study Area, BC-1 (cont.)

Scientific Name	Common Name	SRANK ¹	SARO ²	COSEWIC ³	SARA Schedule ³	Hamilton Status ⁴	OBBA (17PH08) ⁵	NHIC Data ⁶	MNRF SAR List ⁷	NRSI Observed
Tyrannidae		Tyrant Flycatchers								
<i>Contopus virens</i>	Eastern Wood-Pewee	S4B	SC	SC		C	PR		X	X
<i>Empidonax virescens</i>	Acadian Flycatcher	S2S3B	END	E	Schedule 1	R			X	
<i>Empidonax alnorum</i>	Alder Flycatcher	S5B				U	PR			
<i>Empidonax traillii</i>	Willow Flycatcher	S5B				C	CO			X
<i>Empidonax minimus</i>	Least Flycatcher	S4B				U	PO			
<i>Sayornis phoebe</i>	Eastern Phoebe	S5B				U	CO			X
<i>Myiarchus crinitus</i>	Great Crested Flycatcher	S4B				C	CO			X
<i>Tyrannus tyrannus</i>	Eastern Kingbird	S4B				A	CO			X
Laniidae		Shrikes								
<i>Lanius ludovicianus</i>	Loggerhead Shrike	S2B	END	E (ssp. <i>migran</i>)	Schedule 1	EX			X	
Vireonidae		Vireos								
<i>Vireo solitarius</i>	Blue-headed Vireo	S5B				R				X
<i>Vireo philadelphicus</i>	Philadelphia Vireo	S5B								X
<i>Vireo gilvus</i>	Warbling Vireo	S5B				C	PR			X
<i>Vireo olivaceus</i>	Red-eyed Vireo	S5B				C	CO			X
Corvidae		Crows & Jays								
<i>Cyanocitta cristata</i>	Blue Jay	S5				A	CO			X
<i>Corvus brachyrhynchos</i>	American Crow	S5B				C	CO			X
<i>Corvus corax</i>	Common Raven	S5				R				X
Alaudidae		Larks								
<i>Eremophila alpestris</i>	Horned Lark	S5B				C	CO			
Hirundinidae		Swallows								
<i>Progne subis</i>	Purple Martin	S4B				U	CO			
<i>Tachycineta bicolor</i>	Tree Swallow	S4B				A	CO			X
<i>Stelgidopteryx serripennis</i>	Northern Rough-winged Swallow	S4B				C	CO			X
<i>Riparia riparia</i>	Bank Swallow	S4B	THR	T		U	PO		X	
<i>Hirundo rustica</i>	Barn Swallow	S4B	THR	T		C	CO		X	X
Paridae		Chickadees & Titmice								
<i>Poecile atricapillus</i>	Black-capped Chickadee	S5				A	CO			X
<i>Baeolophus bicolor</i>	Tufted Titmouse	S4				R	PO			
Sittidae		Nuthatches								
<i>Sitta canadensis</i>	Red-breasted Nuthatch	S5				U	CO			X
<i>Sitta carolinensis</i>	White-breasted Nuthatch	S5				C	PR			X
Certhiidae		Creepers								
<i>Certhia americana</i>	Brown Creeper	S5B				U				X
Troglodytidae		Wrens								
<i>Troglodytes aedon</i>	House Wren	S5B				C	CO			X
<i>Troglodytes hiemalis</i>	Winter Wren	S5B				U	PO			X
<i>Cistothorus platensis</i>	Sedge Wren	S4B	NAR	NAR		R	PO			
<i>Cistothorus palustris</i>	Marsh Wren	S4B				U	PO			
<i>Thryothorus ludovicianus</i>	Carolina Wren	S4				R	PR			X

Scientific Name	Common Name	SRANK ¹	SARO ²	COSEWIC ³	SARA Schedule ³	Hamilton Status ⁴	OBBA (17PH08) ⁵	NHIC Data ⁶	MNRF SAR List ⁷	NRSI Observed
Poliptilidae		Gnatcatchers								
<i>Poliptila caerulea</i>	Blue-gray Gnatcatcher	S4B				U	PR			
Regulidae		Kinglets								
<i>Regulus satrapa</i>	Golden-crowned Kinglet	S5B				R				X
<i>Regulus calendula</i>	Ruby-crowned Kinglet	S4B								X
Turdidae		Thrushes								
<i>Sialia sialis</i>	Eastern Bluebird	S5B	NAR	NAR		U	CO			X
<i>Catharus fuscescens</i>	Veery	S4B				C	PR			X
<i>Catharus minimus</i>	Gray-cheeked Thrush	S2S4B								X
<i>Catharus ustulatus</i>	Swainson's Thrush	S4B								X
<i>Catharus guttatus</i>	Hermit Thrush	S5B								X
<i>Hylocichla mustelina</i>	Wood Thrush	S4B	SC	T		C	PR		X	X
<i>Turdus migratorius</i>	American Robin	S5B				A	CO			X
Mimidae		Mockingbirds, Thrashers & Allies								
<i>Dumetella carolinensis</i>	Gray Catbird	S4B				A	CO			X
<i>Toxostoma rufum</i>	Brown Thrasher	S4B				U	CO			X
<i>Mimus polyglottos</i>	Northern Mockingbird	S4				U	CO			
Sturnidae		Starlings								
<i>Sturnus vulgaris</i>	European Starling	SNA				A (I)	CO			X
Bombycillidae		Waxwings								
<i>Bombycilla cedrorum</i>	Cedar Waxwing	S5B				C	CO			X
Passeridae		Old World Sparrows								
<i>Passer domesticus</i>	House Sparrow	SNA				A (I)	CO			X
Motacillidae		Pipits								
<i>Anthus rubescens</i>	American Pipit	S4								X
Fringillidae		Finches & Allies								
<i>Carpodacus mexicanus</i>	House Finch	SNA				A (I)	CO			X
<i>Spinus tristis</i>	American Goldfinch	S5B				A	CO			X
Parulidae		Wood Warblers								
<i>Seiurus aurocapillus</i>	Ovenbird	S4B				C	PO			X
<i>Parkesia noveboracensis</i>	Northern Waterthrush	S5B				C				X
<i>Vermivora chrysoptera</i>	Golden-winged Warbler	S4B	SC	T	Schedule 1	R			X	
<i>Mniotilta varia</i>	Black-and-white Warbler	S5B				U				X
<i>Protonotaria citrea</i>	Prothonotary Warbler	S1B	END	E	Schedule 1	R	PO		X	
<i>Oreothlypis peregrina</i>	Tennessee Warbler	S5B								X
<i>Oreothlypis ruficapilla</i>	Nashville Warbler	S5B				U				X
<i>Geothlypis trichas</i>	Common Yellowthroat	S5B				C	PR			X
<i>Setophaga ruticilla</i>	American Redstart	S5B				U	PO			X
<i>Setophaga tigrina</i>	Cape May Warbler	S5B								X
<i>Setophaga cerulea</i>	Cerulean Warbler	S3B	THR	E	Schedule 1	R			X	
<i>Setophaga americana</i>	Northern Parula	S4B								X
<i>Setophaga magnolia</i>	Magnolia Warbler	S5B				R				X
<i>Setophaga castanea</i>	Bay-breasted Warbler	S5B								X

Scientific Name	Common Name	SRANK ¹	SARO ²	COSEWIC ³	SARA Schedule ³	Hamilton Status ⁴	OBBA (17PH08) ⁵	NHIC Data ⁶	MNRF SAR List ⁷	NRSI Observed	
<i>Setophaga fusca</i>	Blackburnian Warbler	S5B				R				X	
<i>Setophaga petechia</i>	Yellow Warbler	S5B				A	CO			X	
<i>Setophaga pensylvanica</i>	Chestnut-sided Warbler	S5B				U	PO				
<i>Setophaga striata</i>	Blackpoll Warbler	S4B								X	
<i>Setophaga caerulescens</i>	Black-throated Blue Warbler	S5B				R				X	
<i>Setophaga palmarum</i>	Palm Warbler	SNRB								X	
<i>Setophaga coronata</i>	Yellow-rumped Warbler	S5B				R				X	
<i>Setophaga virens</i>	Black-throated Green Warbler	S5B				R				X	
<i>Cardellina canadensis</i>	Canada Warbler	S4B	SC	T	Schedule 1	R	PO		X		
<i>Cardellina pusilla</i>	Wilson's Warbler	S4B								X	
<i>Icteria virens</i>	Yellow-breasted Chat	S2B	END	E	Schedule 1	R			X		
Emberizidae New World Sparrows & Allies											
<i>Pipilo erythrophthalmus</i>	Eastern Towhee	S4B				U	PO			X	
<i>Spizella arborea</i>	American Tree Sparrow	S4B								X	
<i>Spizella passerina</i>	Chipping Sparrow	S5B				A	CO			X	
<i>Spizella pusilla</i>	Field Sparrow	S4B				C	CO			X	
<i>Pooecetes gramineus</i>	Vesper Sparrow	S4B				U	PR				
<i>Passerculus sandwichensis</i>	Savannah Sparrow	S4B				A	CO			X	
<i>Ammodramus savannarum</i>	Grasshopper Sparrow	S4B	SC	SC		U	PO		X		
<i>Ammodramus henslowii</i>	Henslow's Sparrow	SHB	END	E	Schedule 1	EX			X		
<i>Melospiza melodia</i>	Song Sparrow	S5B				A	CO			X	
<i>Melospiza georgiana</i>	Swamp Sparrow	S5B				C	PR			X	
<i>Zonotrichia albicollis</i>	White-throated Sparrow	S5B				U				X	
<i>Junco hyemalis</i>	Dark-eyed Junco	S5B								X	
Cardinalidae Cardinals, Grosbeaks & Allies											
<i>Piranga olivacea</i>	Scarlet Tanager	S4B				U	PO				
<i>Cardinalis cardinalis</i>	Northern Cardinal	S5				A	CO			X	
<i>Pheucticus ludovicianus</i>	Rose-breasted Grosbeak	S4B				C	CO			X	
<i>Passerina cyanea</i>	Indigo Bunting	S4B				C	CO			X	
Icteridae Blackbirds											
<i>Dolichonyx oryzivorus</i>	Bobolink	S4B	THR	T	No Schedule	U	CO		X	X	
<i>Agelaius phoeniceus</i>	Red-winged Blackbird	S4				A	CO			X	
<i>Sturnella magna</i>	Eastern Meadowlark	S4B	THR	T	No Schedule	U	CO	X	X		
<i>Euphagus carolinus</i>	Rusty Blackbird	S4B	NAR	SC	Schedule 1					X	
<i>Quiscalus quiscula</i>	Common Grackle	S5B				A	CO			X	
<i>Molothrus ater</i>	Brown-headed Cowbird	S4B				A	CO			X	
<i>Icterus spurius</i>	Orchard Oriole	S4B				U	PR				
<i>Icterus galbula</i>	Baltimore Oriole	S4B				C	CO			X	
							Total	101	1	31	105

¹MNRF 2019a, ²MNRF 2019b, ³Gov. of Canada 2019, ⁴HCA 2014, ⁵BSC et al. 2006, ⁶NHIC 2019; ⁷MNRF 2019c

Mammal Species Reported From the Study Area, BC-1

Scientific Name	Common Name	SRANK ¹	SARO ²	COSEWIC ³	SARA Schedule ³	Ontario Mammal Atlas ⁵	NHIC Data ⁶	MNRF SAR List ⁷	NRSI Observed
Didelphimorphia		Opossums							
<i>Didelphis virginiana</i>	Virginia Opossum	S4				X			X
Insectivora		Shrews and Moles							
<i>Blarina brevicauda</i>	Northern Short-tailed Shrew	S5				X			X
<i>Condylura cristata</i>	Star-nosed Mole	S5				X			
<i>Parascalops breweri</i>	Hairy-tailed Mole	S4				X			
<i>Sorex cinereus</i>	Masked Shrew	S5				X			
<i>Sorex fumeus</i>	Smoky Shrew	S5				X			
Chiroptera		Bats							
<i>Eptesicus fuscus</i>	Big Brown Bat	S4				X			X
<i>Lasionycteris noctivagans</i>	Silver-haired Bat	S4				X			X
<i>Lasiurus borealis</i>	Eastern Red Bat	S4				X			X
<i>Lasiurus cinereus</i>	Hoary Bat	S4				X			X
<i>Myotis</i> sp.	Unidentified <i>Myotis</i> species*								X*
<i>Myotis leibii</i>	Eastern Small-footed Myotis	S2S3	END					X	*
<i>Myotis lucifugus</i>	Little Brown Myotis	S4	END	E	Schedule 1	X		X	*
<i>Myotis septentrionalis</i>	Northern Myotis	S3	END	E	Schedule 1			X	*
<i>Perimyotis subflavus</i>	Tri-colored Bat	S3?	END	E	Schedule 1	X		X	*
Lagomorpha		Rabbits and Hares							
<i>Lepus europaeus</i>	European Hare	SNA				X			
<i>Sylvilagus floridanus</i>	Eastern Cottontail	S5				X			X
Rodentia		Rodents							
<i>Castor canadensis</i>	Beaver	S5				X			
<i>Erethizon dorsatum</i>	Porcupine	S5				X			
<i>Glaucomys volans</i>	Southern Flying Squirrel	S4	NAR	NAR		X			
<i>Marmota monax</i>	Woodchuck	S5				X			
<i>Microtus pennsylvanicus</i>	Meadow Vole	S5				X			
<i>Microtus pinetorum</i>	Woodland Vole	S3?	SC	SC	Schedule 1	X		X	
<i>Napaeozapus insignis</i>	Woodland Jumping Mouse	S5				X			
<i>Ondatra zibethicus</i>	Muskrat	S5				X			
<i>Peromyscus leucopus</i>	White-footed Mouse	S5				X			
<i>Peromyscus maniculatus</i>	Deer Mouse	S5				X			
<i>Rattus norvegicus</i>	Norway Rat	SNA				X			

Mammal Species Reported From the Study Area, BC-1 (cont.)

Scientific Name	Common Name	SRANK ¹	SARO ²	COSEWIC ³	SARA Schedule ³	Ontario Mammal Atlas ⁵	NHIC Data ⁶	MNRF SAR List ⁷	NRSI Observed
<i>Sciurus carolinensis</i>	Eastern Gray Squirrel	S5				X			X
<i>Tamiasciurus hudsonicus</i>	Red Squirrel	S5				X			
<i>Tamias striatus</i>	Eastern Chipmunk	S5				X			X
<i>Zapus hudsonius</i>	Meadow Jumping Mouse	S5				X			
Carnivora		Carnivores							
<i>Canis latrans</i>	Coyote	S5				X			X
<i>Mephitis mephitis</i>	Striped Skunk	S5				X			
<i>Mustela erminea</i>	Ermine	S5				X			
<i>Mustela frenata</i>	Long-tailed Weasel	S4				X			
<i>Mustela vison</i>	American Mink	S4				X			X
<i>Procyon lotor</i>	Northern Raccoon	S5				X			X
<i>Taxidea taxus jacksoni</i>	American Badger	S2	END	E	Schedule 1			X	
<i>Urocyon cinereoargenteus</i>	Grey Fox	S1	THR	T	Schedule 1	X		X	
<i>Vulpes vulpes</i>	Red Fox	S5				X			X
Artiodactyla		Deer and Bison							
<i>Odocoileus virginianus</i>	White-tailed Deer	S5				X			X
Total						38	0	7	15

*See discussion of bat survey results.

Butterfly Species Reported From the Study Area, BC-1

Scientific Name	Common Name	SRANK ¹	SARO ²	COSEWIC ³	SARA Schedule ³	Hamilton Status ⁵	TEA Atlas ⁶ (17PH08)	NHIC Data ¹	MNRF SAR List ⁷	NRSI Observed
Hesperiidae		Skippers								
<i>Anatrytone logan</i>	Delaware Skipper	S4				C	X			
<i>Ancyloxypha numitor</i>	Least Skipper	S5				C	X			
<i>Epargyreus clarus</i>	Silver-spotted Skipper	S4				C	X			
<i>Erynnis baptisiae</i>	Wild Indigo Duskywing	S4				U	X			X
<i>Erynnis martialis</i>	Mottled Duskywing	S2	END	E		R			X	
<i>Euphyes conspicua</i>	Black Dash	S3				C	X			
<i>Euphyes dion</i>	Dion Skipper	S4				U	X			
<i>Pholisora catullus</i>	Common Sootywing	S4				U	X			
<i>Poanes viator</i>	Broad-winged Skipper	S4				C	X			
<i>Polites peckius</i>	Peck's Skipper	S5				C	X			
<i>Polites themistocles</i>	Tawny-edged Skipper	S5				C	X			
<i>Thymelicus lineola</i>	European Skipper	SNA				C	X			X
Papilionidae		Swallowtails								
<i>Papilio glaucus</i>	Eastern Tiger Swallowtail	S5				C	X			X
<i>Papilio polyxenes</i>	Black Swallowtail	S5				C	X			
<i>Papilio troilus</i>	Spicebush Swallowtail	S4				R	X			
Pieridae		Whites and Sulphurs								
<i>Colias eurytheme</i>	Orange Sulphur	S5				C	X			
<i>Colias philodice</i>	Clouded Sulphur	S5					X			X
<i>Pieris rapae</i>	Cabbage White	SNA				C	X			X
<i>Pieris virginianensis</i>	West Virginia White	S3		SC		U			X	
<i>Zerene cesonia</i>	Southern Dogface	SNA					X			
Lycaenidae		Harvesters, Coppers, Hairstreaks, Blues								
<i>Celastrina neglecta</i>	Summer Azure	S5				C				X
<i>Cupido comyntas</i>	Eastern Tailed Blue	S5				C	X			
<i>Satyrium calanus</i>	Banded Hairstreak	S4				C	X			
<i>Satyrium caryaevorus</i>	Hickory Hairstreak	S4				U	X			
<i>Satyrium edwardsii</i>	Edwards' Hairstreak	S4				R	X			
<i>Satyrium liparops</i>	Striped Hairstreak	S5				C	X			

Butterfly Species Reported From the Study Area, BC-1 (cont.)

Scientific Name	Common Name	SRANK ¹	SARO ²	COSEWIC ³	SARA Schedule ³	Hamilton Status ⁵	TEA Atlas ⁶ (17PH08)	NHIC Data ¹	MNRF SAR List ⁷	NRSI Observed
Nymphalidae		Brush-footed Butterflies								
<i>Cercyonis pegala</i>	Common Wood-Nymph	S5				C	X			
<i>Coenonympha tullia</i>	Common Ringlet	S5				C	X			X
<i>Danaus plexippus</i>	Monarch	S2N, S4B	SC	E	Schedule 1	C	X		X	X
<i>Junonia coenia</i>	Common Buckeye	SNA				U	X			
<i>Lethe antheodon</i>	Northern Pearly-Eye	S5				C	X			
<i>Lethe appalachia</i>	Appalachian Brown	S4				C	X			X
<i>Lethe eurydice</i>	Northern Eyed Brown	S5				C	X			
<i>Limenitis archippus</i>	Viceroy	S5				C	X			
<i>Limenitis arthemis astyanax</i>	Red-spotted Purple	S5				C	X			
<i>Megisto cymela</i>	Little Wood-Satyr	S5				C				X
<i>Nymphalis antiopa</i>	Mourning Cloak	S5				C	X			
<i>Phyciodes cocyta</i>	Northern Crescent	S5					X			
<i>Phyciodes tharos</i>	Pearl Crescent	S4				C				X
<i>Polygonia comma</i>	Eastern Comma	S5				C	X			
<i>Polygonia comma</i>	Eastern Comma/Hop	S5					X			
<i>Polygonia interrogationis</i>	Question Mark	S5				C	X			X
<i>Speyeria cybele</i>	Great Spangled Fritillary	S5				C	X			
<i>Vanessa atalanta</i>	Red Admiral	S5				C	X			X
<i>Vanessa cardui</i>	Painted Lady	S5				C	X			X
<i>Vanessa virginiensis</i>	American Lady	S5				C	X			
Total							41	0	3	14

¹MNRF 2019a, ²MNRF 2018a, ³Gov. of Canada 2018, ⁴HCA 2014, ⁵MacNaughton et al. 2018, ⁶MNRF 2019c

Dragonfly and Damselfly Species Reported From the Study Area, BC-1

Scientific Name	Common Name	SRANK ¹	SARO ²	COSEWIC ³	SARA Schedule ³	Hamilton Status ⁴	Odonate Atlas ⁵	NHIC ⁶	MNRF SAR List ⁷	NRSI Observed
Coenagrionidae		Narrow-winged Damselflies								
<i>Enallagma anna</i>	River Bluet	S2				U	X			
<i>Ischnura verticalis</i>	Eastern Forktail	S5				C	X			
Aeshnidae		Darners								
<i>Anax junius</i>	Common Green Darner	S5				C	X			X
Libellulidae		Skimmers								
<i>Celithemis elisa</i>	Calico Pennant	S5				C				X
<i>Erythemis simplicicollis</i>	Eastern Pondhawk	S5				C	X			X
<i>Libellula luctuosa</i>	Widow Skimmer	S5				C	X			X
<i>Libellula pulchella</i>	Twelve-spotted Skimmer	S5				C	X			
<i>Plathemis lydia</i>	Common Whitetail	S5				C	X			
<i>Sympetrum obtrusum</i>	White-faced Meadowhawk	S5				C				X
						Total	7	0	0	5

¹MNRF 2019a, ²MNRF 2019b, ³Gov. of Canada 2019, ⁴HCA 2014, ⁵MNRF 2019d, ⁶NHIC 2019, ⁷MNRF 2019c

Reptile and Amphibian Species Reported From the Study Area, BC-1

Scientific Name	Common Name	SRANK ¹	SARO ²	COSEWIC ³	SARA Schedule ³	Hamilton Status ⁴	ORAA ⁵	NHIC Data ⁶	MNRF SAR List ⁷	NRSI Observed
Turtles										
<i>Apalone spinifer spinifera</i>	Spiny Softshell	S3	THR	E	Schedule 1	R			X	
<i>Chelydra serpentina serpentina</i>	Snapping Turtle	S3	SC	SC	Schedule 1	C	X		X	
<i>Chrysemys picta marginata</i>	Midland Painted Turtle	S5		SC		C	X			
<i>Emydoidea blandingii</i>	Blanding's Turtle (GLSL pop.)	S3	THR	T	Schedule 1	R	X		X	
<i>Graptemys geographica</i>	Northern Map Turtle	S3	SC	SC	Schedule 1	R			X	
<i>Sternotherus odoratus</i>	Eastern Musk Turtle	S3	SC	SC	Schedule 1	R	X		X	
Snakes										
<i>Crotalus horridus</i>	Timber Rattlesnake	SX	EXP	XT	Schedule 1	EX		X		
<i>Pantherophis spiloides pop. 2</i>	Gray Ratsnake (Carolinian pop.)	S1	END	E	Schedule 1				X	
<i>Heterodon platirhinos</i>	Eastern Hog-nosed Snake	S3	THR	T	Schedule 1				X	
<i>Lampropeltis triangulum</i>	Eastern Milksnake	S4	NAR	SC	Schedule 1	U	X			
<i>Opheodrys vernalis</i>	Smooth Greensnake	S4				R	X			
<i>Nerodia sipedon sipedon</i>	Northern Watersnake	S5	NAR	NAR		R	X			
<i>Storeria dekayi dekayi</i>	Northern Brownsnake	S5	NAR	NAR		U	X			X
<i>Storeria occipitomaculata occipitomaculata</i>	Northern Red-bellied Snake	S5				R	X			X
<i>Thamnophis sauritus septentrionalis</i>	Eastern Ribbonsnake	S3	SC	SC	Schedule 1	R			X	
<i>Thamnophis sirtalis sirtalis</i>	Eastern Gartersnake	S5				C	X			X
Salamanders										
<i>Ambystoma jeffersonianum</i>	Jefferson Salamander	S2	END	E	Schedule 1	R	X	X	X	
<i>Ambystoma laterale - (2) jeffersonianum</i>	Unisexual Ambystoma Jefferson Salamander	S2	END	E					X	
<i>Ambystoma sp.</i>	Jefferson/Blue-spotted Salamander Comp.	S2					X			
<i>Ambystoma laterale</i>	Blue-spotted Salamander	S4				R	X			
<i>Notophthalmus viridescens viridescens</i>	Red-spotted Newt	S5				R	X			
<i>Plethodon cinereus</i>	Eastern Red-backed Salamander	S5				C	X			
Toads and Frogs										
<i>Anaxyrus americanus</i>	American Toad	S5				C	X			X
<i>Hyla versicolor</i>	Tetraploid Gray Treefrog	S5				C	X			X
<i>Pseudacris triseriata pop. 1</i>	Western Chorus Frog (Carolinian pop.)	S4	NAR	NAR		C				X
<i>Pseudacris crucifer</i>	Spring Peeper	S5				C	X			X
<i>Lithobates catesbeiana</i>	American Bullfrog	S4				U	X			
<i>Lithobates clamitans melanota</i>	Northern Green Frog	S5				C	X			
<i>Lithobates pipiens</i>	Northern Leopard Frog	S5	NAR	NAR		C	X			X
<i>Lithobates sylvaticus</i>	Wood Frog	S5				C	X			
Total							22	2	10	8

¹MNRF 2019a; ²MNRF 2019b; ³Gov. of Canada 2019; ⁴HCA 2014; ⁵Ontario Nature 2018; ⁶NHIC 2019; ⁷MNRF 2019c

Fish Species Reported from the Study Area, BC-1

Scientific Name	Common Name	SRANK ¹	SARO ²	COSEWIC ³	SARA Schedule ³	NHIC Data ⁴	MNRF SAR List ⁵	NRSI Observed
Petromyzontidae		Lampreys						
<i>Ichthyomyzon fossor</i>	Northern Brook Lamprey (GL-USL Pop.)	S3	SC	SC	Schedule 1		X	
<i>Ichthyomyzon unicuspis</i>	Silver Lamprey (GL-USL Pop.)	S3	SC	SC			X	
Acipenseridae		Sturgeons						
<i>Acipenser fulvescens</i>	Lake Sturgeon (GL-USL Pop.)	S2	THR	Non-active	NONE		X	
Anguillidae		Freshwater Eels						
<i>Anguilla rostrata</i>	American Eel	S1?	END	THR	NONE		X	
Cyprinidae		Carps and Minnows						
<i>Clinostomus elongatus</i>	Redside Dace	S2	END	E	Schedule 1		X	
<i>Notropis photogenis</i>	Silver Shiner	S2S3	THR	T	Schedule 3		X	
<i>Pimephales promelas</i>	Fathead Minnow	S5						X
Catostomidae		Suckers						
<i>Moxostoma duquesnei</i>	Black Redhorse	S2	THR	T			X	
Ictaluridae		North American Catfishes						
<i>Ameiurus nebulosus</i>	Brown Bullhead	S5						X
Esocidae		Pikes						
<i>Esox americanus vermiculatus</i>	Grass Pickerel	S3	SC	SC	Schedule 1		X	
Gasterosteidae		Sticklebacks						
<i>Culaea inconstans</i>	Brook Stickleback	S5						X
Centrarchidae		Sunfishes and Basses						
<i>Lepomis gibbosus</i>	Pumpkinseed	S5						X
					Total	0	8	4

¹MNRF 2019a, ²MNRF 2019b, ³Gov. of Canada 2019, ⁴NHIC 2019, ⁵MNRF 2019c

Vascular Plant Species Reported From the Study Area, SC-8

Scientific Name	Common Name	CC	CW	Weed	SRANK ¹	SARO ²	COSEWIC ³	HRCA NAI ⁴	NHIC ¹	NRSI Observations				
										Fallow Field	MAM2-2	SWT2-13	Hedgerow	
Gymnosperms														
Conifers														
Cupressaceae														
Cypress Family														
<i>Juniperus virginiana</i>	Red Cedar	4	3		S5									X
Dicotyledons														
Dicots														
Aceraceae														
Maple Family														
<i>Acer negundo</i>	Manitoba Maple	0	-2		S5			X					X	
Anacardiaceae														
Sumac or Cashew Family														
<i>Rhus typhina</i>	Staghorn Sumac	1	5		S5			X						X
Apiaceae														
Carrot or Parsley Family														
<i>Cicuta maculata</i>	Spotted Water-hemlock	6	-5		S5			X		X				
<i>Daucus carota</i>	Wild Carrot		5	-2	SE5			I			X	X	X	X
Asclepiadaceae														
Milkweed Family														
<i>Asclepias syriaca</i>	Common Milkweed	0	5		S5			X			X	X		
Asteraceae														
Composite or Aster Family														
<i>Ambrosia artemisiifolia</i>	Common Ragweed	0	3		S5			X		X	X			
<i>Arctium minus</i>	Common Burdock		5	-2	SE5			I		X	X			
<i>Bidens frondosa</i>	Devil's Beggar-ticks	3	-3		S5			X			X			
<i>Cichorium intybus</i>	Chicory		5	-1	SE5			I		X	X			
<i>Cirsium arvense</i>	Canada Thistle		3	-1	SE5			I		X	X	X		
<i>Cirsium vulgare</i>	Bull Thistle		4	-1	SE5			I		X	X			
<i>Conyza canadensis</i>	Horseweed	0	1		S5			X		X				
<i>Erigeron annuus</i>	Daisy Fleabane	0	1		S5			X		X	X	X		
<i>Erigeron philadelphicus</i>	Philadelphia Fleabane	1	-3		S5			X		X				
<i>Eurybia macrophylla</i>	Large-leaved Aster	5	5		S5			X			X			
<i>Euthamia graminifolia</i>	Flat-topped Bushy Goldenrod	2	-2		S5			X			X	X		
<i>Gnaphalium uliginosum</i>	Low Cudweed		0	-1	SE5			I		X				
<i>Lactuca serriola</i>	Prickly Lettuce		0	-1	SE5			I		X				
<i>Leucanthemum vulgare</i>	Ox-eye Daisy		5	-1	SE5			I		X	X			X
<i>Matricaria discoidea</i>	Pineapple-weed				SE5			I		X				
<i>Solidago canadensis</i>	Canada Goldenrod	1	3		S5			X		X	X	X	X	X
<i>Sonchus arvensis ssp. arvensis</i>	Field Sow-thistle				SE5			I		X	X			
<i>Sonchus asper ssp. asper</i>	Spiny-leaved Sow-thistle		0	-1	SE5			I			X			
<i>Sonchus oleraceus</i>	Common Sow-thistle		3	-1	SE5			I		X				X
<i>Symphotrichum lanceolatum var. lanceolatum</i>	Tall White Aster	3	-3		S5			X			X			
<i>Symphotrichum novae-angliae</i>	New England Aster	2	-3		S5			X		X	X	X		
<i>Symphotrichum pilosum var. pilosum</i>	Hairy Aster	4	2		S5			X			X			
<i>Symphotrichum puniceum</i>	Purple-stemmed Aster				S5						X			
<i>Xanthium spinosum</i>	Spiny Cocklebur		3	-1	SE2?					X	X	X		
Balsaminaceae														
Touch-me-not Family														
<i>Impatiens capensis</i>	Spotted Touch-me-not	4	-3		S5			X		X	X			
Brassicaceae														
Mustard Family														
<i>Alliaria petiolata</i>	Garlic Mustard		0	-3	SE5			I				X		
<i>Hesperis matronalis</i>	Dame's Rocket		5	-3	SE5			I				X		
<i>Raphanus raphanistrum</i>	Wild Radish		5	-1	SE3					X		X		
Caprifoliaceae														
Honeysuckle Family														
<i>Lonicera tatarica</i>	Tartarian Honeysuckle		3	-3	SE5			I				X		
Caryophyllaceae														
Pink Family														
<i>Dianthus armeria</i>	Deptford Pink		5	-1	SE5			I						X

Vascular Plant Species Reported From the Study Area, SC-8 (cont.)

Scientific Name	Common Name	CC	CW	Weed	SRANK ¹	SARO ²	COSEWIC ³	HRCA NAI ⁴	NHIC ¹	NRSI Observations			
										Fallow Field	MAM2-2	SWT2-13	Hedgerow
Chenopodiaceae		Goosefoot Family											
<i>Chenopodium simplex</i>	Maple-leaved Goosefoot	0	-5		S5			U			X		
Cornaceae		Dogwood Family											
<i>Cornus foemina</i> ssp. <i>racemosa</i>	Red Panicked Dogwood	2	-2		S5			X		X		X	X
<i>Cornus stolonifera</i>	Red-osier Dogwood	2	-3		S5			X				X	
Dipsacaceae		Teasel Family											
<i>Dipsacus fullonum</i> ssp. <i>sylvestris</i>	Wild Teasel		5	-1	SE5			I		X	X		
Euphorbiaceae		Spurge Family											
<i>Acalypha virginica</i> var. <i>rhomboidea</i>	Three-seeded Mercury	0	3		S5			X		X			
Fabaceae		Pea Family											
<i>Glycine max</i>	Soya Bean		5	-1	SE2					X			
<i>Lotus corniculatus</i>	Bird's-foot Trefoil		1	-2	SE5			I		X	X		
<i>Medicago lupulina</i>	Black Medick		1	-1	SE5			I		X			
<i>Trifolium pratense</i>	Red Clover		2	-2	SE5			I		X	X		
<i>Vicia cracca</i>	Tufted Vetch		5	-1	SE5			I		X	X	X	
Fagaceae		Beech Family											
<i>Quercus macrocarpa</i>	Bur Oak	5	1		S5			X				X	X
Guttiferae		St. John's-wort Family											
<i>Hypericum perforatum</i>	Common St. John's-wort		5	-3	SE5			I			X		
Juglandaceae		Walnut Family											
<i>Carya ovata</i>	Shagbark Hickory	6	3		S5			X					X
Lamiaceae		Mint Family											
<i>Lycopus americanus</i>	Cut-leaved Water-horehound	4	-5		S5			X			X		
<i>Lycopus europaeus</i>	European Water-horehound		-5	-2	SE5			I			X	X	
Lythraceae		Loosestrife Family											
<i>Lythrum salicaria</i>	Purple Loosestrife		-5	-3	SE5			I			X	X	
Oleaceae		Olive Family											
<i>Fraxinus americana</i>	White Ash	4	3		S5			X			X		X
<i>Fraxinus pennsylvanica</i>	Green Ash	3	-3		S5			X				X	
<i>Ligustrum vulgare</i>	Common Privet		1	-2	SE5			I				X	
Onagraceae		Evening-primrose Family											
<i>Ludwigia palustris</i>	Marsh Purslane	5	-5		S5			X		X			
Oxalidaceae		Wood Sorrel Family											
<i>Oxalis stricta</i>	Upright Yellow Wood-sorrel	0	3		S5			X		X		X	
Plantaginaceae		Plantain Family											
<i>Plantago major</i>	Common Plantain		-1	-1	SE5			I		X			
Polygonaceae		Smartweed Family											
<i>Polygonum aviculare</i>	Prostrate Knotweed		1	-1	SNA			X		X			
<i>Polygonum persicaria</i>	Lady's-thumb		-3	-1	SE5			I		X			
<i>Rumex acetosella</i>	Sheep Sorrel		0		SNA			I			X		
<i>Rumex crispus</i>	Curly-leaf Dock		-1	-2	SE5			I		X	X	X	
Ranunculaceae		Buttercup Family											
<i>Ranunculus acris</i>	Tall Buttercup		-2	-2	SE5			I				X	

Vascular Plant Species Reported From the Study Area, SC-8 (cont.)

Scientific Name	Common Name	CC	CW	Weed	SRANK ¹	SARO ²	COSEWIC ³	HRCA NAI ⁴	NHIC ¹	NRSI Observations			
										Fallow Field	MAM2-2	SWT2-13	Hedgerow
<i>Ranunculus pensylvanicus</i>	Bristly Buttercup	3	-5		S5			X					
<i>Ranunculus sceleratus</i>	Cursed Buttercup	2	-5		S5			X		X			
Rhamnaceae		Buckthorn Family											
<i>Rhamnus cathartica</i>	European Buckthorn		3	-3	SE5			I				X	X
Rosaceae		Rose Family											
<i>Crataegus species</i>	Hawthorn species											X	X
<i>Fragaria virginiana</i>	Wild Strawberry				S5			X		X		X	
<i>Geum aleppicum</i>	Yellow Avens	2	-1		S5			X		X	X	X	
<i>Malus domestica</i>	Apple												X
<i>Potentilla norvegica</i>	Rough Cinquefoil				S5			I		X			
<i>Potentilla recta</i>	Rough-fruited Cinquefoil		5	-2	SE5			I				X	
<i>Prunus avium</i>	Cherry Plum		5	-2	SE4			I					X
<i>Prunus serotina</i>	Black Cherry	3	3		S5			X					X
<i>Pyrus communis</i>	Common Pear		5	-1	SE4			I				X	X
<i>Rosa rubiginosa</i>	Sweetbrier Rose		5	-1	SE4			I					X
<i>Rubus occidentalis</i>	Black Raspberry	2	5		S5			X					X
Salicaceae		Willow Family											
<i>Populus deltoides</i> ssp. <i>deltoides</i>	Eastern Cottonwood	4	-1		S5			X			X		
<i>Populus tremuloides</i>	Trembling Aspen	2	0		S5			X					X
<i>Salix species</i>	Willow species												X
<i>Salix fragilis</i>	Crack Willow		-1	-3	SE5			I				X	
Simaroubaceae		Ailanthus Family											
<i>Ailanthus altissima</i>	Tree-of-heaven		5	-1	SE5			I					X
Ulmaceae		Elm Family											
<i>Ulmus americana</i>	White Elm	3	-2		S5			X				X	X
Urticaceae		Nettle Family											
<i>Urtica dioica</i> ssp. <i>dioica</i>	European Stinging Nettle		-1	-1	SE2			I				X	
Verbenaceae		Vervain Family											
<i>Verbena hastata</i>	Blue Vervain	4	-4		S5			X			X		
<i>Verbena urticifolia</i>	White Vervain	4	-1		S5			X			X		
Vitaceae		Grape Family											
<i>Vitis riparia</i>	Riverbank Grape	0	-2		S5			X				X	X
Monocotyledons		Monocots											
Alismataceae		Water-plantain Family											
<i>Alisma plantago-aquatica</i>	Common Water-plantain	3	-5		S5			X		X	X	X	
Cyperaceae		Sedge Family											
<i>Carex vulpinoidea</i>	Fox Sedge	3	-5		S5			X			X		
<i>Eleocharis obtusa</i>	Blunt Spike-rush	5	-5		S5			X		X	X		
<i>Schoenoplectus tabernaemontani</i>	American Great Bulrush	5	-5		S5						X		
Juncaceae		Rush Family											
<i>Juncus tenuis</i>	Path Rush	0	0		S5			X			X		
Lemnaceae		Duckweed Family											
<i>Lemna minor</i>	Lesser Duckweed	2	-5		S5			X			X		
Liliaceae		Lily Family											
<i>Allium canadense</i> var. <i>canadense</i>	Wild Garlic	8	3		S5			X			X		

Vascular Plant Species Reported From the Study Area, SC-8 (cont.)

Scientific Name	Common Name	CC	CW	Weed	SRANK ¹	SARO ²	COSEWIC ³	HRCA NAI ⁴	NHIC ¹	NRSI Observations			
										Fallow Field	MAM2-2	SWT2-13	Hedgerow
Poaceae		Grass Family											
<i>Echinochloa crusgalli</i>	Common Barnyard Grass		-3	-1	SE5			I				X	
<i>Hordeum jubatum</i>	Squirrel-tail Grass		-1	-1	SE5			I		X	X		
<i>Leersia oryzoides</i>	Rice Cut Grass	3	-5		S5			X			X		
<i>Panicum capillare</i>	Witch Grass	0	0		S5			X		X			
<i>Phalaris arundinacea</i>	Reed Canary Grass	0	-4		S5			X			X	X	
<i>Phleum pratense</i>	Timothy		3	-1	SE5			I		X	X		
<i>Phragmites australis</i> ssp. <i>australis</i>	European Common Reed				SNA			I					X
<i>Poa pratensis</i>	Kentucky Bluegrass	0	1		S5			I		X	X		
Typhaceae		Cattail Family											
<i>Typha angustifolia</i>	Narrow-leaved Cattail	3	-5		S5			X		X		X	
<i>Typha latifolia</i>	Broad-leaved Cattail	3	-5		S5			X			X	X	
Total									0	48	54	38	24
											104		

¹MNRF 2019a; ²MNRF 2019b; ³COSEWIC 2019; ⁴HRCA 2014

Bird Species Reported From the Study Area, SC-8

Scientific Name	Common Name	SRANK ¹	SARO ²	COSEWIC ³	SARA Schedule ⁴	HRCNAI ⁴	OBBA ⁵	NRSI Observations
Anatidae		Ducks, Geese & Swans						
<i>Branta canadensis</i>	Canada Goose	S5				C	CO	
<i>Cygnus olor</i>	Mute Swan	SNA				R (I)	CO	
<i>Cygnus buccinator</i>	Trumpeter Swan	S4	NAR	NAR		R		X
<i>Aix sponsa</i>	Wood Duck	S5				U	CO	
<i>Anas platyrhynchos</i>	Mallard	S5				C	CO	
Phasianidae		Partridges, Grouse & Turkeys						
<i>Phasianus colchicus</i>	Ring-necked Pheasant	SNA				R (I)	PR	
<i>Meleagris gallopavo</i>	Wild Turkey	S5				C	CO	
Columbidae		Pigeons & Doves						
<i>Columba livia</i>	Rock Pigeon	SNA				A	CO	
<i>Zenaidura macroura</i>	Mourning Dove	S5				A	CO	PO
Cuculiformes		Cuckoos & Anis						
<i>Coccyzus americanus</i>	Yellow-billed Cuckoo	S4B				R	PR	
<i>Coccyzus erythrophthalmus</i>	Black-billed Cuckoo	S5B				U	PO	
Apodidae		Swifts						
<i>Chaetura pelagica</i>	Chimney Swift	S4B, S4N	THR	T	Schedule 1	U	PR	
Trochilidae		Hummingbirds						
<i>Archilochus colubris</i>	Ruby-throated Hummingbird	S5B				U	PR	
Rallidae		Railles, Gallinules & Coots						
<i>Rallus limicola</i>	Virginia Rail	S5B				U	PR	
<i>Porzana carolina</i>	Sora	S4B				U	PR	
Charadriidae		Plovers						
<i>Charadrius vociferus</i>	Killdeer	S5B, S5N				A	CO	PO
Scolopacidae		Waders						
<i>Bartramia longicauda</i>	Upland Sandpiper	S4B				R	CO	
<i>Scolopax minor</i>	American Woodcock	S4B				C	CO	
<i>Actitis macularia</i>	Spotted Sandpiper	S5				C	CO	PR
Laridae		Gulls, Terns & Skimmers						
<i>Larus delawarensis</i>	Ring-billed Gull	S5B, S4N				A	CO	X
<i>Larus argentatus</i>	Herring Gull	S5B, S5N				C		X
Ardeidae		Hérons & Bitterns						
<i>Ardea herodias</i>	Great Blue Heron	S4B				U	PR	
<i>Butorides virescens</i>	Green Heron	S4B				U	CO	
Cathartidae		Vultures						
<i>Cathartes aura</i>	Turkey Vulture	S5B				U	PR	

Bird Species Reported From the Study Area, SC-8 (cont.)

Scientific Name	Common Name	SRANK ¹	SARO ²	COSEWIC ³	SARA Schedule ⁴	HRCA NAI ⁴	OBBA ⁵	NRSI Observations
Accipitridae		Hawks, Kites, Eagles & Allies						
<i>Circus cyaneus</i>	Northern Harrier	S4B	NAR	NAR		R	PR	
<i>Accipiter striatus</i>	Sharp-shinned Hawk	S5	NAR			R	PO	
<i>Accipiter cooperii</i>	Cooper's Hawk	S4	NAR	NAR		U	CO	
<i>Buteo jamaicensis</i>	Red-tailed Hawk	S5	NAR	NAR		C	CO	
Strigidae		Typical Owls						
<i>Megascops asio</i>	Eastern Screech-Owl	S4	NAR	NAR		U	PO	
<i>Bubo virginianus</i>	Great Horned Owl	S4				C	CO	
<i>Asio flammeus</i>	Short-eared Owl	S2N, S4B	SC	SC	Schedule 3	R	PR	
Alcedinidae		Kingfishers						
<i>Megaceryle alcyon</i>	Belted Kingfisher	S4B				U	PO	
Picidae		Woodpeckers						
<i>Melanerpes erythrocephalus</i>	Red-headed Woodpecker	S4B	SC	END	Schedule 1	R	CO	
<i>Melanerpes carolinus</i>	Red-bellied Woodpecker	S4				U	CO	
<i>Dryobates pubescens</i>	Downy Woodpecker	S5				C	CO	
<i>Dryobates villosus</i>	Hairy Woodpecker	S5				U	PR	
<i>Colaptes auratus</i>	Northern Flicker	S4B				C	CO	PR
Falconidae		Caracaras & Falcons						
<i>Falco sparverius</i>	American Kestrel	S4				U	CO	
Tyrannidae		Tyrant Flycatchers						
<i>Contopus virens</i>	Eastern Wood-Pewee	S4B	SC	SC		C	PR	
<i>Empidonax alnorum</i>	Alder Flycatcher	S5B				U	PR	
<i>Empidonax traillii</i>	Willow Flycatcher	S5B				C	CO	PO
<i>Empidonax minimus</i>	Least Flycatcher	S4B				U	PO	
<i>Sayornis phoebe</i>	Eastern Phoebe	S5B				U	CO	
<i>Myiarchus crinitus</i>	Great Crested Flycatcher	S4B				C	CO	
<i>Tyrannus tyrannus</i>	Eastern Kingbird	S4B				A	CO	PO
Vireonidae		Vireos						
<i>Vireo gilvis</i>	Warbling Vireo	S5B				C	PR	
<i>Vireo olivaceus</i>	Red-eyed Vireo	S5B				C	CO	
Corvidae		Crows & Jays						
<i>Cyanocitta cristata</i>	Blue Jay	S5				A	CO	
<i>Corvus brachyrhynchos</i>	American Crow	S5B				C	CO	PO
Alaudidae		Larks						
<i>Eremophila alpestris</i>	Horned Lark	S5B				C	CO	PO
Hirundinidae		Swallows						
<i>Progne subis</i>	Purple Martin	S4B				U	CO	
<i>Tachycineta bicolor</i>	Tree Swallow	S4B				A	CO	PR
<i>Stelgidopteryx serripennis</i>	Northern Rough-winged Swallow	S4B				C	CO	
<i>Riparia riparia</i>	Bank Swallow	S4B	THR	T		U	PO	
<i>Hirundo rustica</i>	Barn Swallow	S4B	THR	T		C	CO	PO

Bird Species Reported From the Study Area, SC-8 (cont.)

Scientific Name	Common Name	SRANK ¹	SARO ²	COSEWIC ³	SARA Schedule ⁴	HRCA NAI ⁴	OBBA ⁵	NRSI Observations
Paridae		Chickadees & Titmice						
<i>Poecile atricapillus</i>	Black-capped Chickadee	S5				A	CO	
<i>Baeolophus bicolor</i>	Tufted Titmouse	S4				R	PO	
Sittidae		Nuthatches						
<i>Sitta canadensis</i>	Red-breasted Nuthatch	S5				U	CO	
<i>Sitta carolinensis</i>	White-breasted Nuthatch	S5				C	PR	
Troglodytidae		Wrens						
<i>Troglodytes aedon</i>	House Wren	S5B				C	CO	
<i>Troglodytes hiemalis</i>	Winter Wren	S5B				U	PO	
<i>Cistothorus platensis</i>	Sedge Wren	S4B	NAR	NAR		R	PO	
<i>Cistothorus palustris</i>	Marsh Wren	S4B				U	PO	
<i>Thryothorus ludovicianus</i>	Carolina Wren	S4				R	PR	
Poliopitilidae		Gnatcatchers						
<i>Poliopitila caerulea</i>	Blue-gray Gnatcatcher	S4B				U	PR	
Turdidae		Thrushes						
<i>Sialia sialis</i>	Eastern Bluebird	S5B	NAR	NAR		U	CO	
<i>Catharus fuscescens</i>	Veery	S4B				C	PR	
<i>Hyalocichla mustelina</i>	Wood Thrush	S4B	SC	T		C	PR	
<i>Turdus migratorius</i>	American Robin	S5B				A	CO	CO
Mimidae		Mockingbirds, Thrashers & Allies						
<i>Dumetella carolinensis</i>	Gray Catbird	S4B				A	CO	PR
<i>Toxostoma rufum</i>	Brown Thrasher	S4B				U	CO	PR
<i>Mimus polyglottos</i>	Northern Mockingbird	S4				U	CO	PO
Sturnidae		Starlings						
<i>Sturnus vulgaris</i>	European Starling	SNA				A (I)	CO	CO
Bombycillidae		Waxwings						
<i>Bombycilla cedrorum</i>	Cedar Waxwing	S5B				C	CO	PO
Passeridae		Old World Sparrows						
<i>Passer domesticus</i>	House Sparrow	SNA				A (I)	CO	PO
Fringillidae		Finches & Allies						
<i>Carpodacus mexicanus</i>	House Finch	SNA				A (I)	CO	
<i>Spinus tristis</i>	American Goldfinch	S5B				A	CO	PR
Parulidae		Wood Warblers						
<i>Seiurus aurocapillus</i>	Ovenbird	S4B				C	PO	
<i>Protonotaria citrea</i>	Prothonotary Warbler	S1B	END	E	Schedule 1	R	PO	
<i>Geothlypis trichas</i>	Common Yellowthroat	S5B				C	PR	PO
<i>Setophaga ruticilla</i>	American Redstart	S5B				U	PO	
<i>Setophaga petechia</i>	Yellow Warbler	S5B				A	CO	PO
<i>Setophaga pensylvanica</i>	Chestnut-sided Warbler	S5B				U	PO	
<i>Cardellina canadensis</i>	Canada Warbler	S4B	SC	T	Schedule 1	R	PO	

Bird Species Reported From the Study Area, SC-8 (cont.)

Scientific Name	Common Name	SRANK ¹	SARO ²	COSEWIC ³	SARA Schedule ⁴	HRCA NAI ⁴	OBBA ⁵	NRSI Observations	
Emberizidae		New World Sparrows & Allies							
<i>Pipilo erythrophthalmus</i>	Eastern Towhee	S4B				U	PO		
<i>Spizella passerina</i>	Chipping Sparrow	S5B				A	CO	PO	
<i>Spizella pusilla</i>	Field Sparrow	S4B				C	CO		
<i>Poocetes gramineus</i>	Vesper Sparrow	S4B				U	PR		
<i>Passerculus sandwichensis</i>	Savannah Sparrow	S4B				A	CO	PO	
<i>Ammodramus savannarum</i>	Grasshopper Sparrow	S4B	SC	SC		U	PO		
<i>Melospiza melodia</i>	Song Sparrow	S5B				A	CO	CO	
<i>Melospiza georgiana</i>	Swamp Sparrow	S5B				C	PR		
Cardinalidae		Cardinals, Grosbeaks & Allies							
<i>Piranga olivacea</i>	Scarlet Tanager	S4B				U	PO		
<i>Cardinalis cardinalis</i>	Northern Cardinal	S5				A	CO	PO	
<i>Pheucticus ludovicianus</i>	Rose-breasted Grosbeak	S4B				C	CO		
<i>Passerina cyanea</i>	Indigo Bunting	S4B				C	CO	PO	
Icteridae		Blackbirds							
<i>Dolichonyx oryzivorus</i>	Bobolink	S4B	THR	T	No Schedule	U	CO		
<i>Agelaius phoeniceus</i>	Red-winged Blackbird	S4				A	CO	PR	
<i>Sturnella magna</i>	Eastern Meadowlark	S4B	THR	T	No Schedule	U	CO		
<i>Quiscalus quiscula</i>	Common Grackle	S5B				A	CO	PO	
<i>Molothrus ater</i>	Brown-headed Cowbird	S4B				A	CO	PR	
<i>Icterus spurius</i>	Orchard Oriole	S4B				U	PR		
<i>Icterus galbula</i>	Baltimore Oriole	S4B				C	CO		
							Total	101	31

¹MNRF 2019a; ²MNRF 2019b; ³COSEWIC 2019; ⁴HRCA 2014; ⁵BSC et al. 2006

Mammal Species Reported From the Study Area, SC-8

Scientific Name	Common Name	SRANK ¹	SARO ²	COSEWIC ³	HRCA NAI ⁴	Ontario Mammal Atlas ⁵	NHIC ¹	NRSI Observations
Didelphimorphia		Opossums						
<i>Didelphis virginiana</i>	Virginia Opossum	S4			C	X		
Insectivora		Shrews and Moles						
<i>Blarina brevicauda</i>	Northern Short-tailed Shrew	S5			C	X		
<i>Condylura cristata</i>	Star-nosed Mole	S5			C	X		
<i>Parascalops breweri</i>	Hairy-tailed Mole	S4			U	X		
<i>Sorex cinereus</i>	Masked Shrew	S5			C	X		
Chiroptera		Bats						
<i>Eptesicus fuscus</i>	Big Brown Bat	S4			UNK	X		X
<i>Lasionycteris noctivagans</i>	Silver-haired Bat	S4			UNK	X		X
<i>Lasiurus borealis</i>	Eastern Red Bat	S4			UNK	X		X
<i>Lasiurus cinereus</i>	Hoary Bat	S4			UNK	X		X
<i>Myotis lucifugus</i>	Little Brown Myotis	S4	END	E	UNK	X		
Lagomorpha		Rabbits and Hares						
<i>Lepus europaeus</i>	European Hare	SNA			CI	X		
<i>Sylvilagus floridanus</i>	Eastern Cottontail	S5			C	X		X
Rodentia		Rodents						
<i>Castor canadensis</i>	Beaver	S5			C	X		
<i>Glaucomys volans</i>	Southern Flying Squirrel	S4	NAR	NAR	C	X		
<i>Marmota monax</i>	Woodchuck	S5			C	X		
<i>Microtus pennsylvanicus</i>	Meadow Vole	S5			C	X		
<i>Microtus pinetorum</i>	Woodland Vole	S3?	SC	SC	R	X		
<i>Napaeozapus insignis</i>	Woodland Jumping Mouse	S5			U	X		
<i>Ondatra zibethicus</i>	Muskrat	S5			C	X		X
<i>Peromyscus leucopus</i>	White-footed Mouse	S5			C	X		
<i>Rattus norvegicus</i>	Norway Rat	SNA			CI	X		
<i>Sciurus carolinensis</i>	Eastern Gray Squirrel	S5			C	X		
<i>Tamiasciurus hudsonicus</i>	Red Squirrel	S5			C	X		X
<i>Tamias striatus</i>	Eastern Chipmunk	S5			C	X		X
<i>Zapus hudsonius</i>	Meadow Jumping Mouse	S5			C	X		
N/A	Mouse Species	-			-			X

Mammal Species Reported From the Study Area, SC-8 (cont.)

Scientific Name	Common Name	SRANK ¹	SARO ²	COSEWIC ³	HRCA NAI ⁴	Ontario Mammal Atlas ⁵	NHIC ¹	NRSI Observations
Carnivora		Carnivores						
<i>Canis latrans</i>	Coyote	S5			C	X		X
<i>Mephitis mephitis</i>	Striped Skunk	S5			C	X		
<i>Mustela erminea</i>	Ermine	S5			U	X		
<i>Mustela frenata</i>	Long-tailed Weasel	S4			C	X		
<i>Mustela vison</i>	American Mink	S4			C	X		
<i>Procyon lotor</i>	Northern Raccoon	S5			C	X		X
<i>Vulpes vulpes</i>	Red Fox	S5			C	X		
Artiodactyla		Deer and Bison						
<i>Odocoileus virginianus</i>	White-tailed Deer	S5			C	X		X
					Total	33	0	12

¹MNRF 2019a; ²MNRF 2019b; ³COSEWIC 2019; ⁴HRCA 2014; ⁵Dobbyn 1994

Butterfly Species Reported From the Study Area, SC-8

Scientific Name	Common Name	SRANK ¹	SARO ²	COSEWIC ³	HRCA NAI ⁴	TEA Atlas ⁵	NHIC ¹	NRSI Observations
Hesperiidae		Skippers						
<i>Anatrytone logan</i>	Delaware Skipper	S4			C	X		
<i>Ancyloxypha numitor</i>	Least Skipper	S5			C	X		
<i>Epargyreus clarus</i>	Silver-spotted Skipper	S4			C	X		
<i>Erynnis baptisiae</i>	Wild Indigo Duskywing	S4			U	X		
<i>Euphyes conspicua</i>	Black Dash	S3			C	X		
<i>Euphyes dion</i>	Dion Skipper	S4			U	X		
<i>Pholisora catullus</i>	Common Sootywing	S4			U	X		
<i>Poanes viator</i>	Broad-winged Skipper	S4			C	X		
<i>Polites peckius</i>	Peck's Skipper	S5			C	X		
<i>Polites themistocles</i>	Tawny-edged Skipper	S5			C	X		
<i>Thymelicus lineola</i>	European Skipper	SNA			C	X		
	Skipper sp.	-			-			X
Papilionidae		Swallowtails						
<i>Papilio glaucus</i>	Eastern Tiger Swallowtail	S5			C	X		
<i>Papilio polyxenes</i>	Black Swallowtail	S5			C	X		
<i>Papilio troilus</i>	Spicebush Swallowtail	S4			R	X		
Pieridae		Whites and Sulphurs						
<i>Colias eurytheme</i>	Orange Sulphur	S5			C	X		X
<i>Colias philodice</i>	Clouded Sulphur	S5				X		
<i>Pieris rapae</i>	Cabbage White	SNA			C	X		X
<i>Zerene cesonia</i>	Southern Dogface	SNA				X		
Lycaenidae		Harvesters, Coppers,						
<i>Celastrina ssp.</i>	Azure Species	-			-			X
<i>Cupido comyntas</i>	Eastern Tailed Blue	S5			C	X		
<i>Satyrrium calanus</i>	Banded Hairstreak	S4			C	X		
<i>Satyrrium caryaevorus</i>	Hickory Hairstreak	S4			U	X		
<i>Satyrrium edwardsii</i>	Edwards' Hairstreak	S4			R	X		
<i>Satyrrium liparops</i>	Striped Hairstreak	S5			C	X		

Butterfly Species Reported From the Study Area, SC-8 (cont.)

Scientific Name	Common Name	SRANK ¹	SARO ²	COSEWIC ³	HRCA NAI ⁴	TEA Atlas ⁵	NHIC ¹	NRSI Observations
Nymphalidae		Brush-footed Butterflies						
<i>Cercyonis pegala</i>	Common Wood-Nymph	S5			C	X		
<i>Coenonympha tullia</i>	Common Ringlet	S5			C	X		
<i>Danaus plexippus</i>	Monarch	S2N, S4B	SC	E	C	X		X
<i>Junonia coenia</i>	Common Buckeye	SNA			U	X		
<i>Lethe anthedon</i>	Northern Pearly-Eye	S5			C	X		
<i>Lethe appalachia</i>	Appalachian Brown	S4			C	X		
<i>Lethe eurydice</i>	Northern Eyed Brown	S5			C	X		
<i>Limnitis archippus</i>	Viceroy	S5			C	X		
<i>Limnitis arthemis astyanax</i>	Red-spotted Purple	S5			C	X		
<i>Nymphalis antiopa</i>	Mourning Cloak	S5			C	X		
<i>Phyciodes cocyta</i>	Northern Crescent	S5				X		
<i>Polygonia comma</i>	Eastern Comma	S5			C	X		
<i>Polygonia comma</i>	Hop Merchant	S5				X		
<i>Polygonia interrogationis</i>	Question Mark	S5			C	X		
<i>Speyeria cybele</i>	Great Spangled Fritillary	S5			C	X		
<i>Vanessa atalanta</i>	Red Admiral	S5			C	X		
<i>Vanessa cardui</i>	Painted Lady	S5			C	X		X
<i>Vanessa virginiensis</i>	American Lady	S5			C	X		
					Total	41	0	6

¹MNRF 2019a; ²MNRF 2019b; ³COSEWIC 2019; ⁴HRCA 2014; ⁵Macnaughton et al. 2019

Dragonfly and Damselfly Species Reported From the Study Area, SC-8

Scientific Name	Common Name	SRANK ¹	SARO ²	COSEWIC ³	HRCA NAI ⁴	Odonate Atlas ⁵	NHIC ¹	NRSI Observations
Coenagrionidae		Narrow-winged Damselflies						
<i>Enallagma anna</i>	River Bluet	S2			U	X		
<i>Ischnura verticalis</i>	Eastern Forktail	S5			C	X		
Aeshnidae		Darners						
<i>Anax junius</i>	Common Green Darner	S5			C	X		
Libellulidae		Skimmers						
<i>Erythemis simplicicollis</i>	Eastern Pondhawk	S5			C	X		
<i>Libellula luctuosa</i>	Widow Skimmer	S5			C	X		
<i>Libellula pulchella</i>	Twelve-spotted Skimmer	S5			C	X		X
<i>Plathemis lydia</i>	Common Whitetail	S5			C	X		
					Total	7	0	1

¹MNRF 2019a, ²MNRF 2019b, ³COSEWIC 2019, ⁴HRCA 2014, ⁵MNRF 2019c

Reptile and Amphibian Species Reported From the Study Area, SC-8

Scientific Name	Common Name	SRANK ¹	SARO ²	COSEWIC ³	HRCA NAI ⁴	ORAA ⁵	NHIC ¹	NRSI Observations
Turtles								
<i>Chelydra serpentina serpentina</i>	Snapping Turtle	S3	SC	SC	C	X		
<i>Chrysemys picta marginata</i>	Midland Painted Turtle	S5		SC	C	X		
<i>Sternotherus odoratus</i>	Eastern Musk Turtle	S3	SC	SC	R	X		
Snakes								
<i>Ophedrys vernalis</i>	Smooth Greensnake	S4			R	X		
<i>Nerodia sipedon sipedon</i>	Northern Watersnake	S5	NAR	NAR	R	X		
<i>Thamnophis sirtalis sirtalis</i>	Eastern Gartersnake	S5			C	X		
Salamanders								
<i>Ambystoma jeffersonianum</i>	Jefferson Salamander	S2	END	E	R	X		
<i>Ambystoma sp.</i>	Jefferson/Blue-spotted Salamander	S2				X		
<i>Ambystoma laterale</i>	Blue-spotted Salamander	S4			R	X		
<i>Notophthalmus viridescens viridescens</i>	Red-spotted Newt	S5			R	X		
<i>Plethodon cinereus</i>	Eastern Red-backed Salamander	S5			C	X		
Toads and Frogs								
<i>Anaxyrus americanus</i>	American Toad	S5			C	X		
<i>Hyla versicolor</i>	Tetraploid Gray Treefrog	S5			C	X		X
<i>Pseudacris crucifer</i>	Spring Peeper	S5			C	X		
<i>Lithobates catesbeiana</i>	American Bullfrog	S4			U	X		
<i>Lithobates clamitans melanota</i>	Northern Green Frog	S5			C	X		X
<i>Lithobates pipiens</i>	Northern Leopard Frog	S5	NAR	NAR	C	X		
<i>Lithobates sylvaticus</i>	Wood Frog	S5			C	X		
					Total	18	0	2

¹MNRF 2019a; ²MNRF 2019b; ³COSEWIC 2019; ⁴HRCA 2014; ⁵Ontario Nature 2018

Fish Species Reported from the Study Area, SC-8

Scientific Name	Common Name	SRANK ¹	SARO ²	COSEWIC ³	SARA Schedule ⁴	HRCA NAI ⁵	Amec ⁶	NRSI Observations	
Cyprinidae		Carps and Minnows							
<i>Chrosomus eos</i>	Northern Redbelly Dace	S5				C	X		
<i>Margariscus nachtriebi</i>	Northern Pearl Dace	S5				C	X		
<i>Pimephales promelas</i>	Fathead Minnow	S5				C	X		
Umbridae		Mudminnows							
<i>Umbra limi</i>	Central Mudminnow	S5				C	X		
Gasterosteidae		Sticklebacks							
<i>Culaea inconstans</i>	Brook Stickleback	S5				C	X		
Centrarchidae		Sunfishes and Basses							
<i>Lepomis gibbosus</i>	Pumpkinseed	S5				C	X		
							Total	6	0

¹MNRF 2019a; ²MNRF 2019b; ³COSEWIC 2019; ⁴Government of Canada 2019; ⁵HRCA 2014; ⁶Amec 2018

Plant Species Inventoried, Vinemount Swamp

SPECIES_CODE	SCIENTIFIC_NAME_NHIC	COMMON_NAME_NHIC
P-ACERUBR	<i>Acer rubrum</i>	Red Maple
P-ACESACC	<i>Acer saccharinum</i>	Silver Maple
P-ACESASA	<i>Acer saccharum</i>	Sugar Maple
P-ACEXFRE	<i>Acer x freemanii</i>	(<i>Acer rubrum</i> X <i>Acer saccharinum</i>)
P-ACHMILL	<i>Achillea millefolium</i>	Common Yarrow
P-ACT_SP	<i>Actaea</i> sp.	Baneberry Species
P-AGRSTRI	<i>Agrimonia striata</i>	Woodland Agrimony
P-ALIPLAN	<i>Alisma triviale</i>	Northern Water-plantain
P-ALLPETI	<i>Alliaria petiolata</i>	Garlic Mustard
P-AME_SP	<i>Amelanchier</i> sp.	Serviceberry Species
P-AMPBRAC	<i>Amphicarpaea bracteata</i>	American Hog-peanut
P-APOANAN	<i>Apocynum androsaemifolium</i>	Spreading Dogbane
P-ARCMINU	<i>Arctium minus</i>	Common Burdock
P-ARITRTR	<i>Arisaema triphyllum</i> ssp. <i>triphyllum</i>	Jack-in-the-pulpit
P-ASCININ	<i>Asclepias incarnata</i> ssp. <i>incarnata</i>	Swamp Milkweed
P-ASCSYRI	<i>Asclepias syriaca</i>	Common Milkweed
P-BIDFRON	<i>Bidens frondosa</i>	Devil's Beggarticks
P-BOECYLI	<i>Boehmeria cylindrica</i>	False Nettle
P-CALPALS	<i>Calla palustris</i>	Wild Calla
P-CALPALU	<i>Caltha palustris</i>	Yellow Marsh Marigold
P-CARBULB	<i>Cardamine bulbosa</i>	Bulbous Bittercress
P-CARCRIN	<i>Carex crinita</i>	Fringed Sedge
P-CARGRAY	<i>Carex grayi</i>	Gray's Sedge
P-CARINTU	<i>Carex intumescens</i>	Bladder Sedge
P-CARLACU	<i>Carex lacustris</i>	Lake Sedge
P-CARLUPU	<i>Carex lupulina</i>	Hop Sedge
P-CARPRAS	<i>Carex prasina</i>	Drooping Sedge
P-CARROSE	<i>Carex rosea</i>	Rosy Sedge
P-CARCARO	<i>Carpinus caroliniana</i>	Blue-beech
P-CARCORD	<i>Carya cordiformis</i>	Bitternut Hickory
P-CAROVAT	<i>Carya ovata</i>	Shagbark Hickory
P-CENJACE	<i>Centaurea jacea</i>	Brown Knapweed
P-CEPOCCI	<i>Cephalanthus occidentalis</i>	Eastern Buttonbush
P-CERDEME	<i>Ceratophyllum demersum</i>	Common Hornwort
P-CICMACU	<i>Cicuta maculata</i>	Spotted Water-hemlock
P-CIRLUCA	<i>Circaea canadensis</i> ssp. <i>canadensis</i>	Canada Enchanter's Nightshade
P-CLIVULG	<i>Clinopodium vulgare</i>	Field Basil
P-CORFORA	<i>Cornus racemosa</i>	Gray Dogwood
P-CORRUGO	<i>Cornus rugosa</i>	Round-leaved Dogwood
P-CORSTOL	<i>Cornus sericea</i>	Red-osier Dogwood
P-CRA_SP	<i>Crataegus</i> sp.	Hawthorn Species
P-DAUCARO	<i>Daucus carota</i>	Wild Carrot
P-DIAARME	<i>Dianthus armeria</i>	Deptford Pink
P-DIPFUSY	<i>Dipsacus fullonum</i>	Common Teasel

Plant Species Inventoried, Vinemount Swamp (cont.)

SPECIES_CODE	SCIENTIFIC_NAME_NHIC	COMMON_NAME_NHIC
P-EQUHYAF	<i>Equisetum hyemale</i> ssp. <i>affine</i>	Common Scouring-rush
P-ERIANNU	<i>Erigeron annuus</i>	Annual Fleabane
P-ERYAMAM	<i>Erythronium americanum</i> ssp. <i>americanum</i>	Yellow Trout-lily
P-EUOOBOV	<i>Euonymus obovatus</i>	Running Strawberry Bush
P-EUPPERF	<i>Eupatorium perfoliatum</i>	Common Boneset
P-EUTGRAM	<i>Euthamia graminifolia</i>	Grass-leaved Goldenrod
P-FAGGRAN	<i>Fagus grandifolia</i>	American Beech
P-FRAVIVI	<i>Fragaria virginiana</i> ssp. <i>virginiana</i>	Wild Strawberry
P-RHAFRAN	<i>Frangula alnus</i>	Glossy Buckthorn
P-FRAAMER	<i>Fraxinus americana</i>	White Ash
P-FRAPENN	<i>Fraxinus pennsylvanica</i>	Green Ash
P-GALAPAR	<i>Galium aparine</i>	Cleavers
P-GALPALU	<i>Galium palustre</i>	Marsh Bedstraw
P-GERMACU	<i>Geranium maculatum</i>	Spotted Geranium
P-GEUCANA	<i>Geum canadense</i>	White Avens
P-GEULACI	<i>Geum laciniatum</i>	Rough Avens
P-HAMVIRG	<i>Hamamelis virginiana</i>	American Witch-hazel
P-HYPPERF	<i>Hypericum perforatum</i>	Common St. John's-wort
P-ILEVERT	<i>Ilex verticillata</i>	Black Holly
P-IMPCAPE	<i>Impatiens capensis</i>	Spotted Jewelweed
P-IRIVERS	<i>Iris versicolor</i>	Harlequin Blue Flag
P-JUGNIGR	<i>Juglans nigra</i>	Black Walnut
P-JUNEFSSO	<i>Juncus effusus</i> ssp. <i>solutus</i>	Soft Rush
P-JUNTENU	<i>Juncus tenuis</i>	Path Rush
P-LEM_SP	<i>Lemna</i> sp.	Duckweed Species
P-CHRLEUC	<i>Leucanthemum vulgare</i>	Oxeye Daisy
P-LIGVULG	<i>Ligustrum vulgare</i>	European Privet
P-LON_SP	<i>Lonicera</i> sp.	Honeysuckle Species
P-LYCAMER	<i>Lycopus americanus</i>	American Water-horehound
P-LYCUNIF	<i>Lycopus uniflorus</i>	Northern Water-horehound
P-LYSCILI	<i>Lysimachia ciliata</i>	Fringed Loosestrife
P-LYTSALI	<i>Lythrum salicaria</i>	Purple Loosestrife
P-MALPUMI	<i>Malus pumila</i>	Common Apple
P-MEDLUPU	<i>Medicago lupulina</i>	Black Medic
P-MELOFFI	<i>Melilotus officinalis</i>	Yellow Sweet-clover
P-MENARBO	<i>Mentha canadensis</i>	Canada Mint
P-MIMRING	<i>Mimulus ringens</i>	Square-stemmed Monkeyflower
P-MYOLAXA	<i>Myosotis laxa</i>	Small Forget-me-not
P-ONOSENS	<i>Onoclea sensibilis</i>	Sensitive Fern
P-OSTVIRG	<i>Ostrya virginiana</i>	Eastern Hop-hornbeam
P-OXA_SP	<i>Oxalis</i> sp.	Wood-sorrel Species
P-PARINSE	<i>Parthenocissus vitacea</i>	Thicket Creeper
P-POLPENS	<i>Persicaria pensylvanica</i>	Pennsylvania Smartweed
P-POLPUNC	<i>Persicaria punctata</i>	Dotted Smartweed

Plant Species Inventoried, Vinemount Swamp (cont.)

SPECIES_CODE	SCIENTIFIC_NAME_NHIC	COMMON_NAME_NHIC
P-PHAARUN	<i>Phalaris arundinacea</i>	Reed Canary Grass
P-PHLPRAT	<i>Phleum pratense</i>	Common Timothy
P-PHRAUST	<i>Phragmites australis</i>	Common Reed
P-PHRLEPT	<i>Phryma leptostachya</i>	Lopseed
P-HIECACA	<i>Pilosella caespitosa</i>	Meadow Hawkweed
P-PLAMAJO	<i>Plantago major</i>	Common Plantain
P-PODPELT	<i>Podophyllum peltatum</i>	May-apple
P-POL_SP	<i>Polygonum sp.</i>	Smartweed Species
P-POPGRAN	<i>Populus grandidentata</i>	Large-toothed Aspen
P-POPTREM	<i>Populus tremuloides</i>	Trembling Aspen
P-POTNORV	<i>Potentilla norvegica</i>	Norwegian Cinquefoil
P-PRUVULG	<i>Prunella vulgaris</i>	Self-heal
P-PRUVUVU	<i>Prunella vulgaris ssp. vulgaris</i>	Common Self-heal
P-PRUSERO	<i>Prunus serotina</i>	Black Cherry
P-PRUVIVI	<i>Prunus virginiana</i>	Choke Cherry
P-QUEBICO	<i>Quercus bicolor</i>	Swamp White Oak
P-QUEMACR	<i>Quercus macrocarpa</i>	Bur Oak
P-RANABOR	<i>Ranunculus abortivus</i>	Kidney-leaved Buttercup
P-RANHISP	<i>Ranunculus hispidus</i>	Bristly Buttercup
P-RHACATH	<i>Rhamnus cathartica</i>	Common Buckthorn
P-RHUTYPH	<i>Rhus typhina</i>	Staghorn Sumac
P-RIB_SP	<i>Ribes sp.</i>	Currant Species
P-RORPAPA	<i>Rorippa palustris ssp. palustris</i>	Marsh Yellowcress
P-ROSMULT	<i>Rosa multiflora</i>	Multiflora Rose
P-ROSPALU	<i>Rosa palustris</i>	Swamp Rose
P-RUBALLE	<i>Rubus allegheniensis</i>	Allegheny Blackberry
P-RUBIDID	<i>Rubus idaeus ssp. idaeus</i>	Common Red Raspberry
P-RUBIDME	<i>Rubus idaeus ssp. strigosus</i>	Wild Red Raspberry
P-RUBOCCI	<i>Rubus occidentalis</i>	Black Raspberry
P-RUBPUBE	<i>Rubus pubescens</i>	Dewberry
P-RUB_SP	<i>Rubus sp.</i>	Rubus Species
P-RUMCRIS	<i>Rumex crispus</i>	Curly Dock
P-SAL_SP	<i>Salix sp.</i>	Willow Species
P-SCIACUT	<i>Schoenoplectus acutus var. acutus</i>	Hard-stemmed Bulrush
P-SCIVALI	<i>Schoenoplectus tabernaemontani</i>	Soft-stemmed Bulrush
P-SCIMICR	<i>Scirpus microcarpus</i>	Red-tinged Bulrush
P-SMIHISP	<i>Smilax tamnoides</i>	Hispid Greenbrier
P-SOLDULC	<i>Solanum dulcamara</i>	Bittersweet Nightshade
P-SOLALAL	<i>Solidago altissima var. altissima</i>	Eastern Tall Goldenrod
P-SOLCANA	<i>Solidago canadensis</i>	Canada Goldenrod
P-SOLJUNC	<i>Solidago juncea</i>	Early Goldenrod
P-SOLPATU	<i>Solidago patula</i>	Round-leaved Goldenrod
P-SPIALBA	<i>Spiraea alba</i>	White Meadowsweet
P-STEMEDI	<i>Stellaria media</i>	Common Chickweed

Plant Species Inventoried, Vinemount Swamp (cont.)

SPECIES_CODE	SCIENTIFIC_NAME_NHIC	COMMON_NAME_NHIC
P-ASTLALN	<i>Symphotrichum lanceolatum</i> ssp. <i>lanceolatum</i>	Panicked Aster
P-ASTNOVA	<i>Symphotrichum novae-angliae</i>	New England Aster
P-ASTONON	<i>Symphotrichum ontarionis</i>	Ontario Aster
P-ASTPUPU	<i>Symphotrichum puniceum</i> var. <i>puniceum</i>	Swamp Aster
P-ASTUROP	<i>Symphotrichum urophyllum</i>	Arrow-leaved Aster
P-SYR_SP	<i>Syringa</i> sp.	Lilac Species
P-TAROFFI	<i>Taraxacum officinale</i>	Common Dandelion
P-THADIOI	<i>Thalictrum dioicum</i>	Early Meadow-rue
P-THAPUBE	<i>Thalictrum pubescens</i>	Tall Meadow-rue
P-TILAMER	<i>Tilia americana</i>	American Basswood
P-RHURADI	<i>Toxicodendron radicans</i>	Poison Ivy
P-RHURANE	<i>Toxicodendron radicans</i> var. <i>radicans</i>	Eastern Poison Ivy
P-RHURARY	<i>Toxicodendron radicans</i> var. <i>rydbergii</i>	Western Poison Ivy
P-TRIPRAT	<i>Trifolium pratense</i>	Red Clover
P-TUSFARF	<i>Tussilago farfara</i>	Colt's-foot
P-TYPANGU	<i>Typha angustifolia</i>	Narrow-leaved Cattail
P-ULMAMER	<i>Ulmus americana</i>	American Elm
P-ULMRUBR	<i>Ulmus rubra</i>	Slippery Elm
P-URTDIDI	<i>Urtica dioica</i> ssp. <i>dioica</i>	European Stinging Nettle
P-VALOFFI	<i>Valeriana officinalis</i>	Common Valerian
P-VERHAST	<i>Verbena hastata</i>	Blue Vervain
P-VERARVE	<i>Veronica arvensis</i>	Corn Speedwell
P-VIBLENT	<i>Viburnum lentago</i>	Nannyberry
P-VIBRECO	<i>Viburnum recognitum</i>	Smooth Arrowwood
P-VICCRAC	<i>Vicia cracca</i>	Tufted Vetch
P-VIO_SP	<i>Viola</i> sp.	Violet Species
P-VITRIPA	<i>Vitis riparia</i>	Riverbank Grape
P-ZANAMER	<i>Zanthoxylum americanum</i>	Common Prickly-ash

Bird Species Inventoried, Vinemount Swamp

HCA Staff	HCA Staff	NAI	Incidental	Species Code	OFO_Scientific_Name	OFO_Common_Name
		x		B-SPSA	Actitis macularius	Spotted Sandpiper
x		x		B-RWBL	Agelaius phoeniceus	Red-winged Blackbird
		x		B-MALL	Anas platyrhynchos	Mallard
		CO		B-GBHE	Ardea herodias	Great Blue Heron
	x	x		B-CEDW	Bombycilla cedrorum	Cedar Waxwing
		FY		B-RTHA	Buteo jamaicensis	Red-tailed Hawk
x		x		B-NOCA	Cardinalis cardinalis	Northern Cardinal
		x		B-TUVU	Cathartes aura	Turkey Vulture
		x		B-VEER	Catharus fuscescens	Veery
	x	x		B-KILL	Charadrius vociferus	Killdeer
		x		B-MAWR	Cistothorus palustris	Marsh Wren
		x		B-NOFL	Colaptes auratus	Northern Flicker
		x		B-EAWP	Contopus virens	Eastern Wood-Pewee
		x		B-AMCR	Corvus brachyrhynchos	American Crow
		x	x	B-BLJA	Cyanocitta cristata	Blue Jay
		x		B-DOWO	Dryobates pubescens	Downy Woodpecker
		x		B-HAWO	Dryobates villosus	Hairy Woodpecker
	x	x		B-GRCA	Dumetella carolinensis	Gray Catbird
		x		B-ALFL	Empidonax alnorum	Alder Flycatcher
x		x		B-WIFL	Empidonax traillii	Willow Flycatcher
x	x	x		B-COYE	Geothlypis trichas	Common Yellowthroat
x		x		B-BARS	Hirundo rustica	Barn Swallow
		x		B-WOTH	Hylocichla mustelina	Wood Thrush
		x		B-BAOR	Icterus galbula	Baltimore Oriole
		x		B-RBWO	Melanerpes carolinus	Red-bellied Woodpecker
			x	B-WITU	Meleagris gallopavo	Wild Turkey
x	x	x		B-SWSP	Melospiza georgiana	Swamp Sparrow
	x	x		B-SOSP	Melospiza melodia	Song Sparrow
x		x		B-BHCO	Molothrus ater	Brown-headed Cowbird
		x		B-GCFL	Myiarchus crinitus	Great Crested Flycatcher
	x	PO		B-SAVS	Passerculus sandwichensis	Savannah Sparrow
	x	x		B-INBU	Passerina cyanea	Indigo Bunting
		x		B-RBGR	Pheucticus ludovicianus	Rose-breasted Grosbeak
		x		B-BCCH	Poecile atricapillus	Black-capped Chickadee
		SM		B-VESP	Poocetes gramineus	Vesper Sparrow
		x		B-SORA	Porzana carolina	Sora
	x	x		B-COGR	Quiscalus quiscula	Common Grackle
		PO		B-EAPH	Sayornis phoebe	Eastern Phoebe
		x		B-AMWO	Scolopax minor	American Woodcock
x		x		B-YWAR	Setophaga petechia	Yellow Warbler
		x		B-AMRE	Setophaga ruticilla	American Redstart
		x		B-WBNU	Sitta carolinensis	White-breasted Nuthatch
	x	x		B-AMGO	Spinus tristis	American Goldfinch
	x			B-FISP	Spizella pusilla	Field Sparrow
x		x		B-EUST	Sturnus vulgaris	European Starling

Bird Species Inventoried, Vinemount Swamp (cont.)

HCA Staff	HCA Staff	NAI	Incidental	Species_ Code	OFO_Scientific_Name	OFO_Common_Name
		FY		B-TRES	Tachycineta bicolor	Tree Swallow
		x		B-BRTH	Toxostoma rufum	Brown Thrasher
	x	x		B-HOWR	Troglodytes aedon	House Wren
	x	x	x	B-AMRO	Turdus migratorius	American Robin
		x		B-EAKI	Tyrannus tyrannus	Eastern Kingbird
		x		B-WAVI	Vireo gilvus	Warbling Vireo
		x		B-REVI	Vireo olivaceus	Red-eyed Vireo
		P		B-MODO	Zenaida macroura	Mourning Dove
			x	B-WTSP	Zonotrichia albicollis	White-throated Sparrow

Mammal Species Inventoried, Vinemount Swamp			
NAI	Species_Code	Scientific_Name_NHIC	Common_Name_NHIC
x	M-COYO	Canis latrans	Coyote
x	M-VIOP	Didelphis virginiana	Virginia Opossum
x	M-WTDE	Odocoileus virginianus	White-tailed Deer
x	M-RACC	Procyon lotor	Northern Raccoon
x	M-EACO	Sylvilagus floridanus	Eastern Cottontail

Butterflies and Dragonflies Inventoried, Vinemount Swamp			
NAI	Species_Code	NHIC_Scientific_Name	NHIC_Common_Name
x	L-LESK	Ancyloxypha numitor	Least Skipper
x	L-SUAZ	Celastrina neglecta	Summer Azure
x	L-WONY	Cercyonis pegala	Common Wood-Nymph
x	L-CORI	Coenonympha tullia	Common Ringlet
x	L-ORSU	Colias eurytheme	Orange Sulphur
x	L-COSU	Colias philodice	Clouded Sulphur
x	L-VICT	Ctenucha virginica	Virginia Ctenucha
x	L-MONA	Danaus plexippus	Monarch
x	L-BLDA	Euphyes conspicua	Black Dash
x	L-DUSK	Euphyes vestris	Dun Skipper
x	O-COSW	Lestes disjunctus	Northern Spreadwing
x	O-SLSP	Lestes rectangularis	Slender Spreadwing
x	L-AEBR	Lethe appalachia	Appalachian Brown
x	L-VICE	Limenitis archippus	Viceroy
x	L-BRCO	Lycaena hyllus	Bronze Copper
x	L-MOCL	Nymphalis antiopa	Mourning Cloak
x	L-BLSP	Paonias excaecata	Blinded Sphinx
x	L-BLSW	Papilio polyxenes	Black Swallowtail
x	L-PHYPAS	Phyciodes cocyta	Northern Crescent
x	L-CAWH	Pieris rapae	Cabbage White
x	O-COWH	Plathemis lydia	Common Whitetail
x	L-HOSK	Poanes hobomok	Hobomok Skipper
x	L-BWSK	Poanes viator	Broad-winged Skipper
x	L-COMM	Polygonia comma	Eastern Comma
x	L-BAHA	Satyrium calanus	Banded Hairstreak
x	L-GSFR	Speyeria cybele	Great Spangled Fritillary
x	O-WFME	Sympetrum obtrusum	White-faced Meadowhawk
x	L-EUSK	Thymelicus lineola	European Skipper
x	L-READ	Vanessa atalanta	Red Admiral
x	L-AMLA	Vanessa virginiensis	American Lady

Plant Species Inventoried, Tapleystown Woods

SPECIES_CODE	SCIENTIFIC_NAME_NHIC	COMMON_NAME_NHIC
P-ACENEGU	<i>Acer negundo</i>	Manitoba Maple
P-ACESANI	<i>Acer nigrum</i>	Black Maple
P-ACERUBR	<i>Acer rubrum</i>	Red Maple
P-ACESASA	<i>Acer saccharum</i>	Sugar Maple
P-ACEXFRE	<i>Acer x freemanii</i>	(<i>Acer rubrum</i> X <i>Acer saccharinum</i>)
P-ALLPETI	<i>Alliaria petiolata</i>	Garlic Mustard
P-AMELAEV	<i>Amelanchier laevis</i>	Smooth Serviceberry
P-ANEQUIN	<i>Anemone quinquefolia</i>	Wood Anemone
P-ARITRTR	<i>Arisaema triphyllum</i> ssp. <i>triphyllum</i>	Jack-in-the-pulpit
P-BIDFRON	<i>Bidens frondosa</i>	Devil's Beggarticks
P-CARCONC	<i>Cardamine concatenata</i>	Cut-leaved Toothwort
P-CARDIPH	<i>Cardamine diphylla</i>	Two-leaved Toothwort
P-CARGRAY	<i>Carex grayi</i>	Gray's Sedge
P-CARCARO	<i>Carpinus caroliniana</i>	Blue-beech
P-CARCORD	<i>Carya cordiformis</i>	Bitternut Hickory
P-CAROVAT	<i>Carya ovata</i>	Shagbark Hickory
P-CAUGIGA	<i>Caulophyllum giganteum</i>	Giant Blue Cohosh
P-CHEMAJU	<i>Chelidonium majus</i>	Greater Celandine
P-CHESIMP	<i>Chenopodium simplex</i>	Maple-leaved Goosefoot
P-CIRLUCA	<i>Circaea canadensis</i> ssp. <i>canadensis</i>	Canada Enchanter's Nightshade
P-CLAVIRG	<i>Claytonia virginica</i>	Narrow-leaved Spring Beauty
P-CORFORA	<i>Cornus racemosa</i>	Gray Dogwood
P-CRA_SP	<i>Crataegus</i> sp.	Hawthorn Species
P-ERIPHPH	<i>Erigeron philadelphicus</i> var. <i>philadelphicus</i>	Philadelphia Fleabane
P-ERYAMAM	<i>Erythronium americanum</i> ssp. <i>americanum</i>	Yellow Trout-lily
P-EUOOBOV	<i>Euonymus obovatus</i>	Running Strawberry Bush
P-FAGGRAN	<i>Fagus grandifolia</i>	American Beech
P-FLOPROS	<i>Floerkea proserpinacoides</i>	False Mermaidweed
P-FRAVEAM	<i>Fragaria vesca</i> ssp. <i>americana</i>	American Woodland Strawberry
P-FRAVIRG	<i>Fragaria virginiana</i>	Wild Strawberry
P-RHAFRAN	<i>Frangula alnus</i>	Glossy Buckthorn
P-FRAAMER	<i>Fraxinus americana</i>	White Ash
P-FRANIGR	<i>Fraxinus nigra</i>	Black Ash
P-FRAPENN	<i>Fraxinus pennsylvanica</i>	Green Ash
P-GERMACU	<i>Geranium maculatum</i>	Spotted Geranium
P-GERROBE	<i>Geranium robertianum</i>	Herb-Robert
P-GEULACI	<i>Geum laciniatum</i>	Rough Avens
P-HESMATR	<i>Hesperis matronalis</i>	Dame's Rocket
P-HYDVIRG	<i>Hydrophyllum virginianum</i>	Virginia Waterleaf
P-IMPCAPE	<i>Impatiens capensis</i>	Spotted Jewelweed
P-IMPPALL	<i>Impatiens pallida</i>	Pale Jewelweed
P-JUGCINE	<i>Juglans cinerea</i>	Butternut
P-LEOCACA	<i>Leonurus cardiaca</i> ssp. <i>cardiaca</i>	Common Motherwort
P-LIGVULG	<i>Ligustrum vulgare</i>	European Privet
P-MAIRARA	<i>Maianthemum racemosum</i>	Large False Solomon's Seal
P-MATSTPE	<i>Matteuccia struthiopteris</i> var. <i>pennsylvanica</i>	Ostrich Fern
P-MENARBO	<i>Mentha canadensis</i>	Canada Mint
P-OSTVIRG	<i>Ostrya virginiana</i>	Eastern Hop-hornbeam

Plant Species Inventoried, Tapleystown Woods (cont.)

SPECIES_CODE	SCIENTIFIC_NAME_NHIC	COMMON_NAME_NHIC
P-OXAACMO	<i>Oxalis montana</i>	Common Wood-sorrel
P-PARQUIN	<i>Parthenocissus quinquefolia</i>	Virginia Creeper
P-PHRLEPT	<i>Phryma leptostachya</i>	Lopseed
P-PILFONT	<i>Pilea fontana</i>	Lesser Clearweed
P-PILPUMI	<i>Pilea pumila</i>	Dwarf Clearweed
P-PINSTRO	<i>Pinus strobus</i>	Eastern White Pine
P-PLAMAJO	<i>Plantago major</i>	Common Plantain
P-PODPELT	<i>Podophyllum peltatum</i>	May-apple
P-POPGRAN	<i>Populus grandidentata</i>	Large-toothed Aspen
P-PRUAVIU	<i>Prunus avium</i>	Sweet Cherry
P-PRUSERO	<i>Prunus serotina</i>	Black Cherry
P-QUEALBA	<i>Quercus alba</i>	White Oak
P-QUEBICO	<i>Quercus bicolor</i>	Swamp White Oak
P-QUEMACR	<i>Quercus macrocarpa</i>	Bur Oak
P-QUERUBR	<i>Quercus rubra</i>	Northern Red Oak
P-RANRECU	<i>Ranunculus recurvatus</i>	Hooked Buttercup
P-RHACATH	<i>Rhamnus cathartica</i>	Common Buckthorn
P-RIBCYNO	<i>Ribes cynosbati</i>	Prickly Gooseberry
P-RIBLACU	<i>Ribes lacustre</i>	Bristly Black Currant
P-RORPALU	<i>Rorippa palustris</i>	Marsh Yellowcress
P-ROSMULT	<i>Rosa multiflora</i>	Multiflora Rose
P-RUBALLE	<i>Rubus allegheniensis</i>	Allegheny Blackberry
P-RUBIDME	<i>Rubus idaeus</i> ssp. <i>strigosus</i>	Wild Red Raspberry
P-RUBOCCI	<i>Rubus occidentalis</i>	Black Raspberry
P-RUBODOR	<i>Rubus odoratus</i>	Purple-flowering Raspberry
P-SAL_SP	<i>Salix</i> sp.	Willow Species
P-SANCANA	<i>Sanguinaria canadensis</i>	Bloodroot
P-SAN_SP	<i>Sanicula</i> sp.	Snakeroot Species
P-SOLALAL	<i>Solidago altissima</i> var. <i>altissima</i>	Eastern Tall Goldenrod
P-SOLFLEX	<i>Solidago flexicaulis</i>	Zigzag Goldenrod
P-SOLHIHI	<i>Solidago hispida</i> var. <i>hispida</i>	Hairy Goldenrod
P-SOL_SP	<i>Solidago</i> sp.	Goldenrod Species
P-ASTLATE	<i>Symphotrichum lateriflorum</i>	Calico Aster
P-TILAMER	<i>Tilia americana</i>	American Basswood
P-TORJAPO	<i>Torilis japonica</i>	Erect Hedge-parsley
P-RHURADI	<i>Toxicodendron radicans</i>	Poison Ivy
P-RHURANE	<i>Toxicodendron radicans</i> var. <i>radicans</i>	Eastern Poison Ivy
P-RHURARY	<i>Toxicodendron radicans</i> var. <i>rydbergii</i>	Western Poison Ivy
P-TRIEREC	<i>Trillium erectum</i>	Red Trillium
P-TRIGRAN	<i>Trillium grandiflorum</i>	White Trillium
P-ULMAMER	<i>Ulmus americana</i>	American Elm
P-ULMRUBR	<i>Ulmus rubra</i>	Slippery Elm
P-URTDIDI	<i>Urtica dioica</i> ssp. <i>dioica</i>	European Stinging Nettle
P-VERTHAP	<i>Verbascum thapsus</i>	Common Mullein
P-VEROFFI	<i>Veronica officinalis</i>	Common Speedwell
P-CYNNIGR	<i>Vincetoxicum nigrum</i>	Black Swallow-wort
P-VIOPUBE	<i>Viola pubescens</i>	Yellow Violet
P-VIOSORO	<i>Viola sororia</i>	Woolly Blue Violet

Plant Species Inventoried, Tapleystown Woods (cont.)

SPECIES_CODE	SCIENTIFIC_NAME_NHIC	COMMON_NAME_NHIC
P-VITRIPA	Vitis riparia	Riverbank Grape
P-XANSTRU	Xanthium strumarium	Rough Cocklebur
P-ZANAMER	Zanthoxylum americanum	Common Prickly-ash

Bird Species Inventoried, Tapleystown Woods

HCA Staff	HCA Staff	HCA Staff	NAI	Incidental Sightings	e-bird Data	Species_Code	OFO_Scientific_Name	OFO_Common_Name
x	x	x	x		x	B-RWBL	Agelaius phoeniceus	Red-winged Blackbird
				x		B-WODU	Aix sponsa	Wood Duck
					x	B-NOPI	Anas acuta	Northern Pintail
	x	x	x			B-MALL	Anas platyrhynchos	Great Crested Flycatcher
	x					B-GBHE	Ardea herodias	Yellow-billed Cuckoo
			x			B-CEDW	Bombycilla cedrorum	Scarlet Tanager
			x		x	B-CAGO	Branta canadensis	Red-tailed Hawk
		x				B-GHOW	Bubo virginianus	American Goldfinch
	x	x	x (VO)	x		B-RTHA	Buteo jamaicensis	American Crow
x	x					B-NOCA	Cardinalis cardinalis	Bobolink
					x	B-KILL	Charadrius vociferus	Killdeer
			x			B-YBCU	Coccyzus americanus	Northern Flicker
	x	x	x (VO)			B-NOFL	Colaptes auratus	Gray Catbird
		x	x			B-EAWP	Contopus virens	Brown-headed Cowbird
	CF					B-AMCR	Corvus brachyrhynchos	Brown Thrasher
x	x	x	x (VO)			B-BLJA	Cyanocitta cristata	Red-eyed Vireo
		x			x	B-BOBO	Dolichonyx oryzivorus	Savannah Sparrow
x						B-DOWO	Dryobates pubescens	Eastern Kingbird
	x					B-GRCA	Dumetella carolinensis	Canada Goose
					x	B-HOLA	Eremophila alpestris	Horned Lark
			x (VO)			B-WOTH	Hylocichla mustelina	Great Blue Heron
					x	B-DEJU	Junco hyemalis	Dark-eyed Junco
				x		B-EASO	Megascops asio	Eastern Screech-Owl
	x	x	x			B-RBWO	Melanerpes carolinus	Song Sparrow
				x		B-RHWO	Melanerpes erythrocephalus	Red-headed Woodpecker
x	x		x			B-SOSP	Melospiza melodia	Blue Jay
x				x		B-BHCO	Molothrus ater	Great Horned Owl
x	x	x				B-GCFL	Myiarchus crinitus	Indigo Bunting
			x			B-SAVS	Passerculus sandwichensis	American Woodcock
		x	x			B-INBU	Passerina cyanea	Downy Woodpecker
	x		x			B-SCTA	Piranga olivacea	Northern Cardinal
					x	B-VESP	Poocetes gramineus	Vesper Sparrow
x	x	x	x		x	B-COGR	Quiscalus quiscula	Common Grackle
	x	x			x	B-AMWO	Scolopax minor	White-breasted Nuthatch

Bird Species Inventoried, Tapleystown Woods (cont.)

HCA Staff	HCA Staff	HCA Staff	NAI	Incidental Sightings	e-bird Data	Species_Code	OFO_Scientific_Name	OFO_Common_Name
x		x	x		x	B-YWAR	Setophaga petechia	American Robin
		x				B-WBNU	Sitta carolinensis	Wood Thrush
			x			B-AMGO	Spinus tristis	House Wren
			x		x	B-FISP	Spizella pusilla	Mallard
					x	B-EUST	Sturnus vulgaris	European Starling
			x		x	B-BRTH	Toxostoma rufum	Red-bellied Woodpecker
	x	x				B-HOWR	Troglodytes aedon	Field Sparrow
x	x	x				B-AMRO	Turdus migratorius	Eastern Wood-Pewee
		x				B-EAKI	Tyrannus tyrannus	Cedar Waxwing
	x		x			B-REVI	Vireo olivaceus	Yellow Warbler

Mammal Species Inventoried, Tapleystown Woods

NAI	incidental	Species_Code	Scientific_Name_NHIC	Common_Name_NHIC
x	x	M-COYO	Canis latrans	Coyote
	x	M-WTDE	Odocoileus virginianus	White-tailed Deer
x	x	M-RACC	Procyon lotor	Northern Raccoon
	x	M-GRSB	Sciurus carolinensis	Eastern Gray Squirrel Black Phase

Butterfly Species Inventoried, Tapleystown Woods				
NAI	iNat	Species_Code	NHIC_Scientific_Name	NHIC_Common_Name
x		L-SUAZ	<i>Celastrina neglecta</i>	Summer Azure
x		L-WONY	<i>Cercyonis pegala</i>	Common Wood-Nymph
x		L-COSU	<i>Colias philodice</i>	Clouded Sulphur
x		L-SSSK	<i>Epargyreus clarus</i>	Silver-spotted Skipper
x		L-JUDW	<i>Erynnis juvenalis</i>	Juvenal's Duskywing
x		L-MOCL	<i>Nymphalis antiopa</i>	Mourning Cloak
	x	L-GISW	<i>Papilio cresphontes</i>	Giant Swallowtail
x		L-TISW	<i>Papilio glaucus</i>	Eastern Tiger Swallowtail
x		L-PECR	<i>Phyciodes tharos</i>	Pearl Crescent
x		L-CAWH	<i>Pieris rapae</i>	Cabbage White
x		L-COMM	<i>Polygonia comma</i>	Eastern Comma
x		L-BAHA	<i>Satyrium calanus</i>	Banded Hairstreak
x		L-GSFR	<i>Speyeria cybele</i>	Great Spangled Fritillary
x		L-EUSK	<i>Thymelicus lineola</i>	European Skipper
x		L-READ	<i>Vanessa atalanta</i>	Red Admiral
x		L-PALA	<i>Vanessa cardui</i>	Painted Lady
x		L-BRDA	<i>Wallengrenia egeremet</i>	Northern Broken-Dash

APPENDIX 7

References

References

A.K.A Gowlings on behalf of Hamilton Conservation Authority. Restrictive Covenant, Received as WE1579403, Ontario Land Registry Office. Archaeological sites subject to Section 48(2) of the Ontario Heritage Act : AhGw-546, AhGW-548, AhGw-550, AhGw-555, AhGw-558 and AhGw-557. Submitted February 1, 2022.

A.T. McLaren Limited, R.A. McLaren O.L.S. Plan of Survey of Part of Lot 22 Concession 5 Geographic Township of Saltfleet in the City of Hamilton. Plan 62 R-21832 Registered Archaeological Sites. January 28, 2022

Detritus Consulting Ltd. Stage 2 Archaeological Assessment HCA BC-1 Project Lands. Hamilton Conservation Authority. November 28, 2020

Detritus Consulting Ltd. Stage 3 Archaeological Assessment, AhGw-557. Hamilton Conservation Authority. August 16, 2021

Detritus Consulting Ltd. Stage 2 Archaeological Assessment Saltfleet Conservation Area SC-8. Hamilton Conservation Authority. October 25, 2022.

Hamilton Conservation Authority Board of Directors. Staff Recommendations Report 6.0 Stoney Creek Flood Plain Acquisition. February 5, 1969.

Hamilton Conservation Authority Board of Directors. Report BD12, Board Approval and Recommendations. East Mountain Wetland Restoration Project. September 4, 2014.

Hamilton Conservation Authority Board of Directors. Delegations Report 4.1 Funding Announcement for East Escarpment Wetland Project. December 4, 2014.

Hamilton Conservation Authority Board of Directors. Report 12.4 Board Approval and Recommendations. Property Acquisition Team – East Mountain Wetland Restoration Project. March 5, 2015.

Hamilton Conservation Authority Board of Directors. Report 5.2 East Mountain Wetland Restoration Project. October 1, 2015

Hamilton Conservation Authority Conservation Advisory Board. Item 10.2 Recognition of Dedicated Service – Jim Howlett, past CAB and Board Member. April 11, 2019

Ministry of Natural Resources, Managed Forest Tax Incentive Program (MFTIP) Guide. Queen's Printer for Ontario. Updated January 2012

Ministry of Northern Development, Mines, Natural Resources and Forestry. Niagara Escarpment Parks and Open Space System Planning Manual (2021). Queen's Printer for Ontario. 2021

Monteith Brown Planning Consultants, in association with Tucker-Reid & Associates and The JF Group. City of Hamilton Recreation Master Plan. City of Hamilton. July 21, 2022

Natural Resource Solutions Inc. Saltfleet Conservation Area Wetland BC-1 Design. Tree Protection Plan. Hamilton Conservation Authority. August 2020

Silv-Econ Ltd., David Puttock R.P.F. Managed Forest Plan 2018-2037. Hamilton Conservation Authority. July 2017

The Bay Observer. First Wetland Completed at New Saltfleet Conservation Area, Trails Open to Public. <https://bayobserver.ca/first-wetland-completed-at-new-saltfleet-conservation-area-trails-open-to-public/> September 20, 2022

The Hamilton Spectator, Stoney Creek News, Richard Leitner. Heritage Green Community Trust \$2M grant foots Saltfleet wetland bill. <https://www.thespec.com/local-stoney-creek/news/2022/01/18/heritage-green-community-trust-2m-grant-foots-saltfleet-wetland-bill.html> January 18, 2022

Water's Edge Environmental Solutions Team. Battlefield Creek Wetland Storage Facility Design Report (BC-1). Hamilton Conservation Authority. August 20, 2021

Water's Edge Environmental Solutions Team. Saltfleet Conservation Area Battlefield Creek BC-1 Wetland Drawings. Hamilton Conservation Authority. August 20, 2021

Water's Edge Environmental Solutions Team. Saltfleet Conservation Area Stoney Creek SC-8 Wetland Drawings. Hamilton Conservation Authority. November 2022.

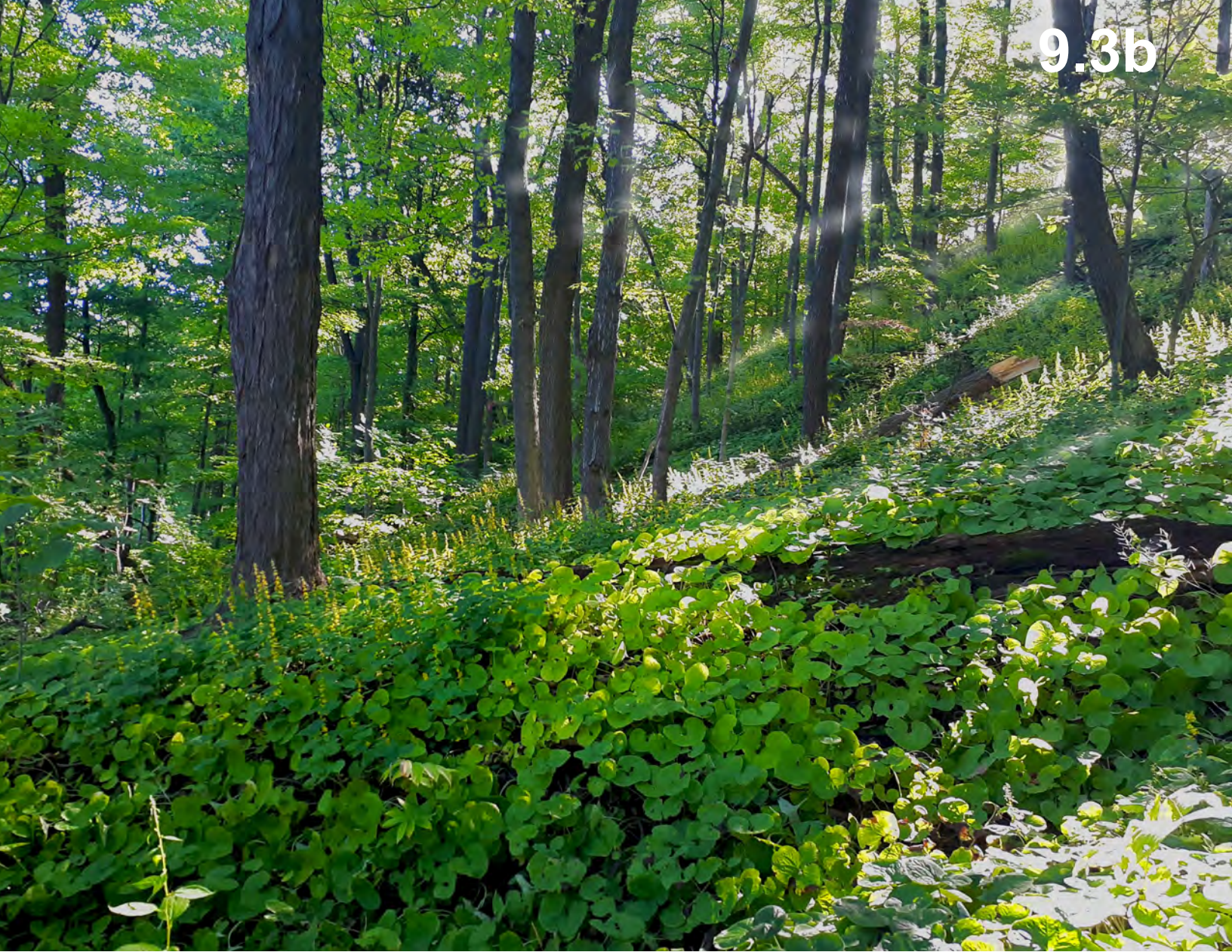


**Hamilton
Conservation
Authority**

A Healthy Watershed for Everyone

Hamilton Conservation Authority
838 Mineral Springs Road, P.O. Box 81067
Ancaster, Ontario, L9G 4X1
905-525-2181 www.conservationhamilton.ca

This page intentionally left blank.



Winona and Vinemount Conservation Areas Management Plan

Draft - March 2024



Hamilton
Conservation
Authority

A Healthy Watershed for Everyone

621



Prepared by: Hamilton Region Conservation Authority (HCA)

Photo Credits: HCA Staff; James Lees.



TABLE OF CONTENTS

1.0	APPROVAL STATEMENT	1
2.0	INTRODUCTION.....	2
2.1	Area Summary	2
2.2	Key Items	4
2.3	Goals and Objectives	4
3.0	BACKGROUND.....	8
3.1	Study Area.....	8
3.2	Property History.....	8
3.3	Planning and Development Controls	12
3.4	Management Plan Zones	12
4.0	NATURAL AREA INVENTORY.....	17
4.1	Natural Features.....	17
4.2	Biophysical Inventory Methodology	17
4.3	Ecological Land Classification	18
4.4	Ecological Land Classification Results	18
4.5	Fauna Inventory Results.....	20
4.6	Aquatic Inventory.....	21
4.7	Significant Ecological Features	21
4.8	Biophysical Inventory Analysis	22
4.9	Natural Areas Recommendations.....	27
5.0	CONSERVATION AREA MANAGEMENT	29
5.1	Land Management	29
5.2	Vegetation Management	29
5.3	Fish and Wildlife Management	32
5.4	Cultural Heritage Management.....	32
5.5	Agricultural	33
5.6	Managed Forest	34
5.7	Conservation Area Operations	34
5.8	Research	34
6.0	MANAGEMENT PRACTICES	36
6.1	Natural Heritage Conservation	36

6.2	Water Management.....	36
6.3	Conservation Area Experiences.....	37
6.4	Education and Environmental Awareness.....	38
6.5	Public Infrastructure – Utilities, Trails and Transportation.....	38
6.6	Management Guidelines.....	38
6.7	Maintenance Guidelines.....	39
7.0	SUMMARY.....	41
7.1	Implementation Priorities.....	41
8.0	APPENDIX CONTENTS.....	42
	Appendix 1 - Mapping.....	43
	Appendix 2 – Capital Development Priorities.....	49
	Appendix 3 – Trail Counter Data.....	51
	Appendix 4 – Natural Inventory – Species List.....	53
	Appendix 5 – References.....	64

LIST OF FIGURES

Figure 1.	Context Map.....	3
Figure 2.	Bruce Trail Map.....	9
Figure 3.	Study Area Map.....	13

LIST OF TABLES

Table 1.	Natural Environment Zone.....	15
Table 2.	Resource Management Zone.....	16
Table 3.	Summary of Ecological Field Studies.....	17
Table 4.	Floristic Summary and Assessment.....	19
Table 5.	Federal and Provincial Species at Risk.....	23
Table 6.	Locally Rare and Uncommon Species.....	24
Table 7.	Species of Conservation Concern.....	27

1.0 APPROVAL STATEMENT

We are pleased to approve the Winona and Vinemount Conservation Areas Management Plan 2022 as the official policy document for the Hamilton Region Conservation Authority (HCA).

This management plan supports HCA's current Strategic Plan and reflects our Vision of a healthy watershed for everyone and Mission to lead in the conservation of our watershed and connect people to nature.

Moving forward over the next ten years this plan will provide guidance for management of Winona and Vinemount Conservation Areas in support of these goals.

Lisa Burnside
Chief Administrative Officer
Hamilton Conservation Authority

Date

Brad Clark
Chair, Board of Directors
Hamilton Conservation Authority

Date

Shawn Carey
NEC Director

Date

Jennifer Keyes
MNR Resource Planning and
Development Policy Branch Director

Date

2.0 INTRODUCTION

2.1 Area Summary

HCA acquired these Escarpment tracts of land to protect them from changes that could be detrimental to their sensitive features and functions. The north facing Escarpment slope is steep and tree covered, and exhibits significant plant communities unique for this area of Southern Ontario. When HCA acquired the lands, the Bruce Trail was in place below the Escarpment crest. The Bruce Trail is the official recreational trail for these conservation areas. The major land use surrounding the conservation areas are farm related with a scattering of rural residences along the adjacent roadways. The study area for this plan is shown in Figure 1. Context Map.

The original Master Development Plans for Winona and Vinemount Conservation Areas (WVCA) were prepared by HCA staff in 1979. This Management Plan is intended to replace both of those plans, consolidate all available information on file, add new information on current conditions, and recommended best management practices to help guide land management decisions for the next ten years.

WVCA is classified as Natural Environment in the Niagara Escarpment Plan (NEP), and the Niagara Escarpment is designated as a UNESCO World Biosphere Reserve. This classification and designation serves to protect the outstanding natural heritage features, cultural heritage resources, and scenic resources at WVCA. This Master Plan supports the biosphere reserve principles so that the Escarpment will remain substantially as a natural environment for future generations.

In preparing this updated plan for both conservation areas, HCA reviewed the current Niagara Escarpment Parks and Open Space System (NEPOSS) Planning Manual concept of grouping multiple parks into one management plan. The following considerations noted in the manual guided this decision:

- The conservation areas are in close proximity with a shared trail system (Bruce Trail)
- They both have the same environmental features and ecological functions.
- They both have the same level of planning complexity.
- Both areas have the same levels of service, operation and management.

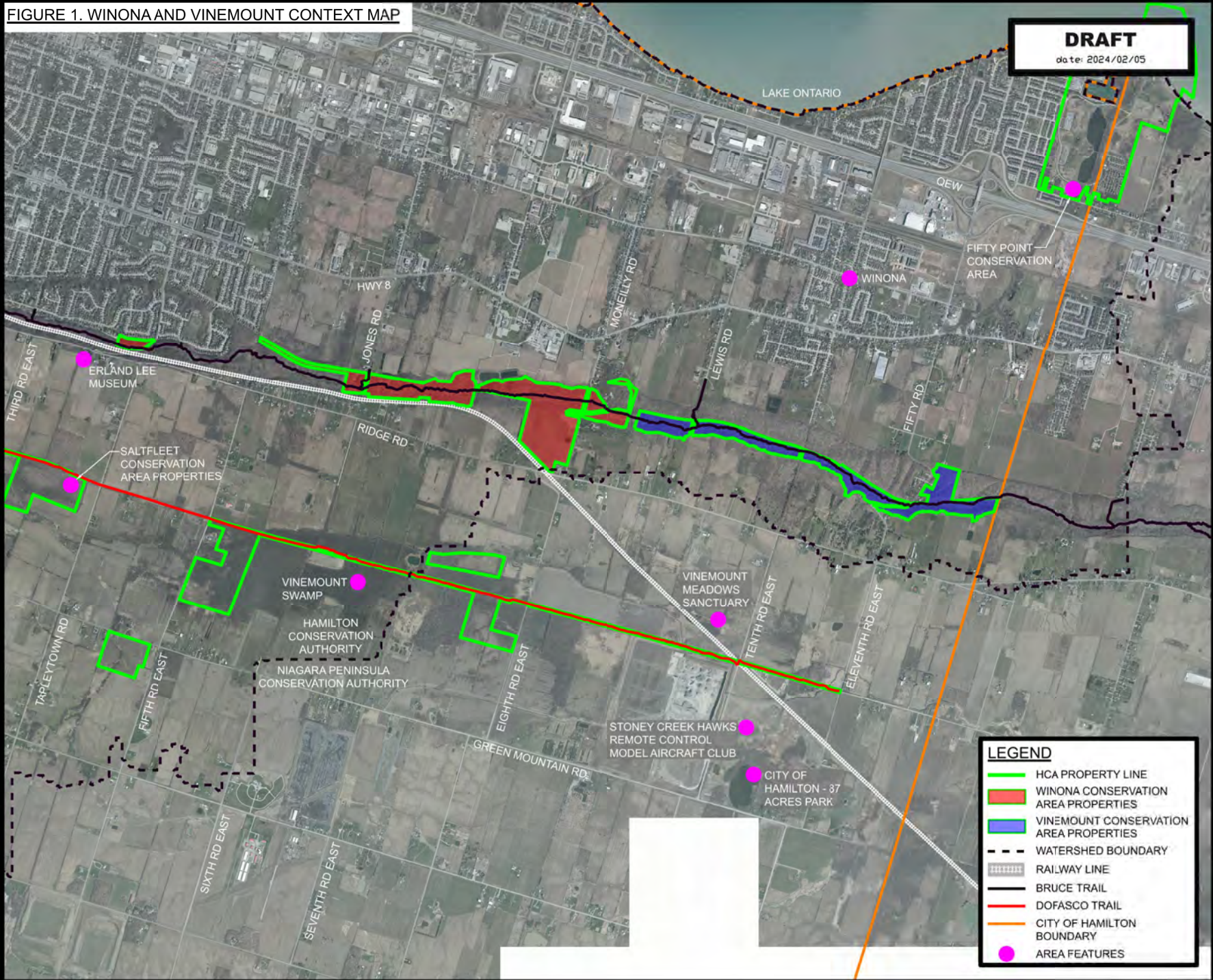
Winona Conservation Area

The 55 ha (137 acres) Winona Conservation Area is located on the Niagara Escarpment in Stoney Creek. It is situated between Devil's Punchbowl Conservation Area 6 km to the west, and Vinemount Conservation Area 3 km east. The Bruce Trail runs through the property and is accessible from Macdui Drive, Jones Road, and McNeilly Road.

Vinemount Conservation Area

The 36 ha (90 acres) Vinemount Conservation Area is located on the Niagara Escarpment in Stoney Creek. The Bruce Trail runs through the property and is accessible from Lewis Road, Winona Road, and Fifty Road. Fifty Point Conservation Area is located 2.5 km to the north.

FIGURE 1. WINONA AND VINEMOUNT CONTEXT MAP



DRAFT
date: 2024/02/05

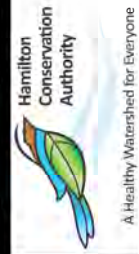


**CONTEXT MAP
WINONA & VINEMOUNT MANAGEMENT PLAN**

DATE: 2024/02/05

LEGEND

- HCA PROPERTY LINE
- WINONA CONSERVATION AREA PROPERTIES
- VINEMOUNT CONSERVATION AREA PROPERTIES
- - - WATERSHED BOUNDARY
- RAILWAY LINE
- BRUCE TRAIL
- DOFASCO TRAIL
- CITY OF HAMILTON BOUNDARY
- AREA FEATURES



A Healthy Watershed for Everyone

2.2 Key Items

The majority of the lands are designated by the province or the municipality as Environmentally Significant Areas (ESAs) or as Areas of Natural and Scientific Interest (ANSIs). The actual designation is determined by many reasons, including significant hydrological function, rare habitat, escarpment land, or species at risk to name a few.

HCA's ownership and management of these lands provides protection of their sensitive features and functions. Access to these lands is restricted to the Bruce Trail, and no other visitor amenities (such as parking) to access the trail are proposed in this plan. These lands contribute to the larger natural heritage system in the City of Hamilton (City) and surrounding municipalities, and contribute to the watershed's biodiversity.

2.3 Goals and Objectives

In 1968, Professor L.O. Gertler of the University of Waterloo prepared a study identifying sensitive Niagara Escarpment lands threatened by urban sprawl. The report made recommendations to the Ontario government to protect these lands through acquisition on a priority basis or through the use of easements and lease agreements.

As a result of the Gertler report, HCA developed a comprehensive Escarpment land acquisition program to help preserve the character of the Niagara Escarpment within its area of jurisdiction. As a part of this program, HCA acquired the Winona and Vinemount lands with a view to establishing recreational nodes at five to eight - kilometer intervals. The purpose of this program was two-fold:

1. To preserve the landscape character of significant features of the Niagara Escarpment.
2. To provide recreational access at specific locations along the Escarpment.

HCA Strategic Plan

This Management Plan supports this Vision for the land acquisition, as well as the following long-term goals as outlined in HCA's current strategic plan:

Vision

- A healthy watershed for everyone.

Mission

- To lead in the conservation of our watershed and connect people to nature.

Commitment and Corporate Values

- Provide excellent customer service and a solution-oriented approach.
- Be accountable, transparent, and responsible in the use of resources.
- Embrace new technologies to help develop new ways of doing business and foster innovation.

- Promote teamwork internally and externally to achieve common goals, support existing relationships and build new partnerships.
- Maintain trust, act with integrity, and treat others with respect.
- Value knowledge to continually learn and improve, in an effort to achieve best solutions.

Organizational Excellence

- Ensure corporate and financial viability and the HCA's relevance in the community.
- Identify opportunities to engage the community, adjacent landowners and Indigenous Peoples.

Water Management

- Protect the watershed for people, property, flora and fauna, and natural resources through flood and erosion control, water quality programs, low flow augmentation and adaptation strategies to adapt to changing climatic conditions.

Natural Heritage Conservation

- Conservation, restoration and enhancement of watershed natural areas and ecology.
- Continue on-going ecological restoration projects and monitoring programs.
- Identify invasive species strategies and natural heritage plans in the Master plan.

Conservation Area Experience

- Provide high quality, diverse conservation areas that promote outdoor recreation, health, and well-being and strengthen public awareness of the importance of being in or near our conservation areas.
- Update and develop Master and Management plans, and implement priorities to further enhance conservation areas for current and future generations.

Education and Environmental Awareness

- Provide outdoor learning experiences for students, teachers and the community, increasing knowledge and awareness of the value of our environment and heritage.



Land Acknowledgement

The HCA joins in stewardship of lands and waters with Indigenous Peoples who have cared for them since time before memory. We acknowledge that the land on which we gather, and the HCA watershed, is part of the Treaty Lands and Territory of the Mississaugas of the Credit First Nation and traditional territory of the Haudenosaunee.

As an organization, we are committed to learning about the shared history and experiences of Indigenous Peoples in Canada and creating relationships based on respect, trust and friendship. In our shared gratitude for every aspect of the natural world, may we create a lasting legacy now and for future generations.

HCA Climate Change Strategy

The goal of HCA's Climate Change Strategy is to work towards achieving net zero status across HCA's operations through the reduction of greenhouse gases (GHG's), while also working to increase our overall adaptive capacity to changing climatic conditions.

Key Areas of Focus

Environment and Natural Heritage

- Water Management
 - Reduce water runoff, contamination, soil erosion, and other impacts of climate change on water systems
 - Reduce flooding and its impacts on lands, communities, and infrastructure
- Wetland Management
 - Identify threats to wetlands and make it easier for ecosystems to adapt to climate change
- Carbon Sequestration
 - Increase natural carbon stores which help remove excess CO₂ from the atmosphere
- Invasive Species
 - Research and monitor invasive species
 - Implement best practices in preventing the spread of invasive species
 - Communicate trends and impacts of invasive species locally
- Protection of Wildlife
 - Mitigate threats to biodiversity
- Monitoring Programs
 - Expand long-term monitoring programs
 - Maintain HCA's planning program as it relates to natural hazards and climate change implications

Experience, Education and Awareness

- Education and Awareness
 - Increase awareness of individual roles in addressing climate change
 - Protect staff and visitor safety

Partnerships

- Strengthen community approach and build systems for collaboration
- Learn from the work of others
- Collaboratively address threats and identify opportunities for climate adaptation and GHG reductions
- Strengthen relationships with Indigenous communities

Objectives

In addition to the above, and through further consultation and analysis during this Management Plan process, HCA supports the following long-term objectives for Winona and Vinemount Conservation Areas:

1. To preserve and protect the Niagara Escarpment.
2. To provide Bruce Trail through access.
3. That recreational facilities be passive, low density uses centred primarily on nature appreciation and trail-oriented activities.
4. To maintain the current agricultural land use agreements, and upon the expiry of those agreements actively restore the lands back to natural areas.



3.0 BACKGROUND

3.1 Study Area

HCA acquired these tracts of land for natural protection, water conservation, and recreational use. Residential land uses in the area consist of scattered rural residences and estates. The lands in the study area are used for passive recreational activities including hiking and nature study. See the appended maps for more information.

3.2 Property History

The HCA recognizes that these conservation area lands were inhabited by First Nations peoples including the Mississaugas of the Credit First Nation, the Haudenosaunee, and the Huron-Wendat. The HCA also recognizes that this area has been, and continues to be, home to many Indigenous peoples including the Métis, Inuit and Urban Indigenous communities.

Non-Indigenous settlement is noted in historic records of the formation of Upper Canada in 1792. Settlement of the area increased in 1786, with loyalist immigrants arriving from New York State in the years following the American Revolutionary War. Crown patents were granted to United Empire Loyalists who settled at first below the escarpment but then spread south creating small hamlets.

Following are key highlights of property history known to HCA at the time of land acquisition for the creation of the conservation areas.

.1 Bruce Trail History

The Bruce Trail Conservancy (BTC) is one of Ontario's largest land trusts and the steward of Canada's longest marked footpath. The "Bruce" of the Bruce Trail refers to the Bruce Peninsula through which the northern-most section of the Trail passes. In the early 1960's as the trail was being conceived, the thought was that this footpath along the full length of the Niagara Escarpment would be a trail "to the Bruce", a popular vacation destination.

The BTC was established in 1960 and by 1963 Regional Clubs were in operation. The Regional Clubs were responsible for organization, landowner approvals, construction and maintenance of portions of the trail. The Iroquoia Bruce Trail Club was formed in Hamilton on September 5, 1963 to build and maintain the BTC main and side trails from Grimsby to the Kelso Conservation Area near Milton.



The Bruce Trail took seven years to complete and was officially opened in 1967, Canada's Centennial Year. The trail runs over 900 km from Queenston to Tobermory, passing along the Escarpment face through the two conservation areas. See Figure 2. Bruce Trail Map.

HCA has a partnership agreement with the BTC and the Iroquoia Bruce Trail Club for the maintenance of the Bruce Trail crossing HCA lands. Representatives of the BTC were consulted in the writing of this Management Plan.

Figure 2. Bruce Trail Map



Map source: Bruce Trail Conservancy

.2 Winona Conservation Area History:

In 1972 the Hamilton-Wentworth Planning Area Board and HCA studied the Vinemount area and selected a suitable site on McNeilly Road for establishing a conservation area. In 1972 HCA secured a 16-ha farmstead atop the Escarpment. The property was acquired in three installments between 1972 and 1973. The Winona Conservation Area was adopted by HCA in 1973 with the acquisition of Part 9, Concession 3 in the former Township of Saltfleet. At the time of purchase, these properties were named Vinemount Conservation Area, but a distinction between Winona and Vinemount Conservation Areas has since been made (see Figure 1). HCA requested and received financial assistance with a grant from the provincial Ministry of Natural Resources, amounting to approximately 75% of the estimated cost of the acquisition. Further acquisitions were anticipated subject to land becoming available and as funding and priorities permitted. Over time, more properties were acquired along the Escarpment.

Major land uses in the area at the time of acquisition included farming and residential scattered along Ridge Road. The land for the most part was in fruit production. This production supplied the E.D. Smith and Sons Limited fruit canning and preserving factory below the Escarpment, 1 km west of the McNeilly Road and Highway 8 intersection. The Vinemount General Store was located on the northwestern corner of McNeilly Road and Regional Road 25 and functioned as the area post office. The T.H. & B. Railway Line ascended the Escarpment west of HCA property on Lot 10, Concession 3.

For the first ten years of HCA ownership, site development was limited to the following:

- Continued operation of the fruit farm
- Approximately 0.5 ha of tableland area at McNeilly Road was developed for day-use with an HCA sign, gravel parking lot for twenty cars, pit privy, split rail fencing, grassed picnic area, and a footpath to viewing areas at the brow of the Escarpment amidst a former cherry orchard.
- HCA and the farmer had service access to the interior of the property via two farm lanes.

HCA entered into a lease agreement to maintain the agricultural operation, the agreement exists to this day for the agricultural land parcel at McNeilly Road and Eighth Road.

The day use facilities that were developed near the Escarpment crest, due to their remote rural location at the time, were vandalised and eventually removed. Remnants of the parking area are still visible from McNeilly Road. The physical constraints to reach the Bruce Trail from this location, combined with a lack of municipal services such as sewage systems, limits HCA's development and use of this property for visitors. Accordingly, no visitor facilities are in place for the conservation area other than the Bruce Trail.

.3 Vinemount Conservation Area History:

One of the first Vinemount Conservation Area properties acquired is located along Fifty Road at the top of the Escarpment. The property was, at one time, in vineyard production but was not known to be a commercial operation. In the early 1970's the area was cleared in preparation for residential development but that idea was turned down by the regional government. When HCA acquired the 3.8ha parcel in 1976 natural succession had taken over much of the lands,

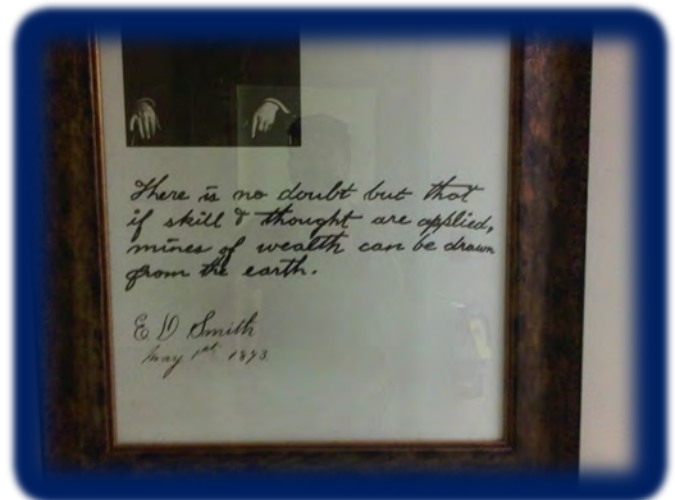
with Escarpment woodlands surrounding the property. HCA acquired the lands with the intent of preserving the Escarpment plateau, 105 meters of road frontage along Fifty Road, and access to the Bruce Trail. The objective was to allow the land to re-generate to a point where the vegetation was of natural composition matching the surrounding Escarpment woodlots.

In addition to the preservation goal, another key goal was land acquisition, especially Escarpment tableland, to provide recreational areas for picnicking, parking, and scenic lookouts. The major land uses nearby at that time were fruit farming (apple, pear, plum and cherry) and grape vineyards. Some estate residential development was occurring along the Escarpment brow. A quarry on Tenth Sideroad East was extracting dolostone, limestone and shale for the building and construction trades.

Although little in the way of history is on file for the conservation area property, much history is available for the surrounding lands. The village of Winona, in the years before Confederation, was known as 'Ontario' and before that 'The Fifty' taken from the creek of the same name. The Great Western Railroad Company built a station in 1850 along the rail line from Hamilton to Vinemount west of what is now Winona Road, and called the stop 'Ontario.' In 1867 when the act of Confederation was passed, the Province of Canada West became the Province of Ontario. The railroad station and area post office as a result, changed their names to 'Winona' after Winonah, the daughter of the Shawnee Indian Chief, Tecumseh. The first area post office was located just to the north of the conservation area on the northeast corner of Fifty Road at Highway 8.

The forests on the Escarpment supplied wood for Piott's basket factory in Stoney Creek in the 1800's. The village of Winona has had many firsts in the history of the Township of Saltfleet including the first community park, watermains, and street lights.

Perhaps the village's most famous citizen, Ernest D'Israeli Smith (1855-1948) introduced Saltfleet's first fruit farming industry in 1875. He was not only a grower but a buyer and shipper of fruit as well as initiating Saltfleet's (and Winona's) first industry in 1882, with the development of the E.D. Smith and Sons food processing plant. This plant remains in use today on Highway 8.



.4 Land Acquisition Notes:

HCA acquired most of the lands for the conservation areas from the early 1970's to the late 1990's. Due to the intensive agriculture on the plain above and below the Escarpment, the Escarpment face and slope were the land parcels HCA focused on acquiring. These lands had multiple constraints to development including the lack of available municipal services, shallow soils, and sensitivity of the Escarpment terraces. A few recent and notable land acquisitions by HCA include:

- Llewellyn Smith and Helderleigh Holdings Inc., formerly E.D. Smith Fruit Farms donated 58 acres (23.47 ha) of forest and fields along the Escarpment face by McNeilly Road to HCA in 2010. This donation was comprised of 15 acres of Escarpment land by the Smith family home, known as Helderleigh House, and 43 acres of field and slope behind the former E.D. Smith food plant. The donation was made public at HCA's board meeting of November 2010.
- In 1976 HCA purchased 9.55 acres in the former Township of Saltfleet for Escarpment preservation purposes, and to potentially establish a link below the Escarpment to Fifty Point Conservation Area. Natural area inventories of the land at that time noted the significance of the Escarpment lands and forest complex for this portion of the Niagara Section of the Escarpment.

3.3 Planning and Development Controls

The conservation areas are located in Wards 9 and 10 – Stoney Creek and subject to the planning and development controls of the City of Hamilton.

The conservation areas lands are subject to additional planning and development controls being entirely within the Niagara Escarpment Plan (NEP) Area and Niagara Escarpment Commission (NEC) Area of Development Control. See Map 3 in Appendix 1 for the boundary mapping. While these NEP lands are within the Greenbelt Plan area, the only policies within the Greenbelt Plan that apply are those under the Greenbelt Plan Section 3.3 Parkland, Open Space and Trails. The conservation areas are also designated in the NEP as Escarpment Natural Area and Escarpment Protection Area. The policies of the Niagara Escarpment Plan and guidelines of the NEPOSS 2021 planning manual have been observed in the preparation of this Management Plan.

HCA recognizes that certain public infrastructure such as utility corridors, trails or transportation links may be required to cross WVCA lands. HCA policy for planning review and regulation of these features adheres to the Conservation Authority Act, R.S.O. 1990 c.27; see Section 6.5 for more information.

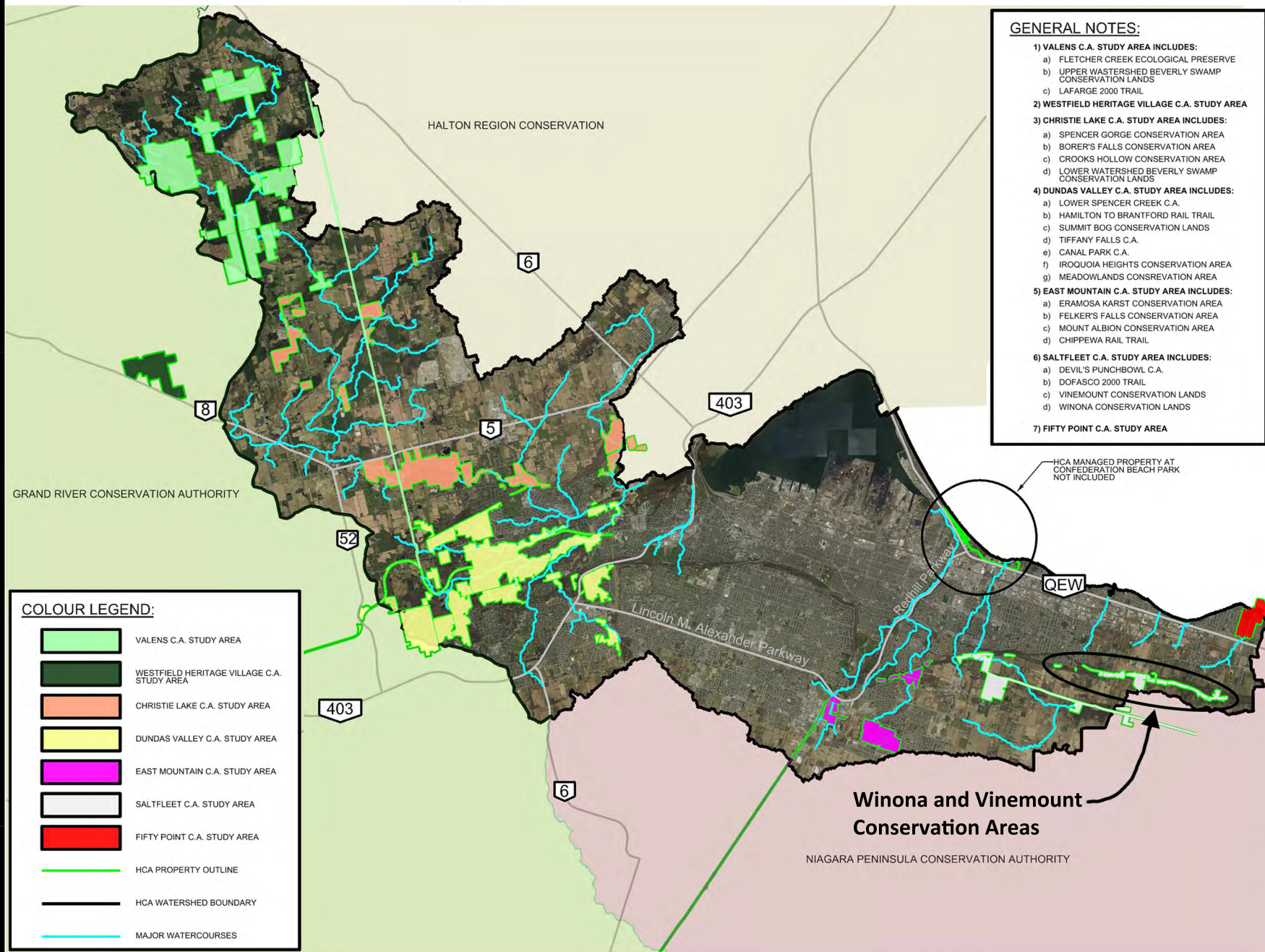
The City of Hamilton planning and development departments, as well as representatives from the Niagara Escarpment Commission; Ministry of Northern Development, Mines, Natural Resources and Forestry; and the NPCA were engaged in the scoping of this Management Plan.

3.4 Management Plan Zones

The appended maps show the Management Plan Zones for the Winona and Vinemount Conservation Areas.

HCA has approached this Management Plan with the mind-set that conservation areas in the HCA portfolio requiring Master or Management Plans and updates follow a consistent methodology as set out in HCA's 10 Year Master Plan Update Strategy. The Map shown in Figure 3. is from this Strategy.

FIGURE 3. HCA 10-YEAR MASTER PLAN STUDY AREA



COLOUR LEGEND:

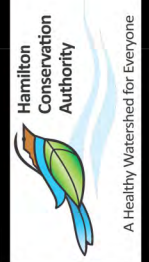
- VALENS C.A. STUDY AREA
- WESTFIELD HERITAGE VILLAGE C.A. STUDY AREA
- CHRISTIE LAKE C.A. STUDY AREA
- DUNDAS VALLEY C.A. STUDY AREA
- EAST MOUNTAIN C.A. STUDY AREA
- SALT FLEET C.A. STUDY AREA
- FIFTY POINT C.A. STUDY AREA
- HCA PROPERTY OUTLINE
- HCA WATERSHED BOUNDARY
- MAJOR WATERCOURSES

- GENERAL NOTES:**
- 1) VALENS C.A. STUDY AREA INCLUDES:
 - a) FLETCHER CREEK ECOLOGICAL PRESERVE
 - b) UPPER WATERSHED BEVERLY SWAMP CONSERVATION LANDS
 - c) LAFARGE 2000 TRAIL
 - 2) WESTFIELD HERITAGE VILLAGE C.A. STUDY AREA
 - 3) CHRISTIE LAKE C.A. STUDY AREA INCLUDES:
 - a) SPENCER GORGE CONSERVATION AREA
 - b) BORER'S FALLS CONSERVATION AREA
 - c) CROOKS HOLLOW CONSERVATION AREA
 - d) LOWER WATERSHED BEVERLY SWAMP CONSERVATION LANDS
 - 4) DUNDAS VALLEY C.A. STUDY AREA INCLUDES:
 - a) LOWER SPENCER CREEK C.A.
 - b) HAMILTON TO BRANTFORD RAIL TRAIL
 - c) SUMMIT BOG CONSERVATION LANDS
 - d) TIFFANY FALLS C.A.
 - e) CANAL PARK C.A.
 - f) IROQUOIA HEIGHTS CONSERVATION AREA
 - g) MEADOWLANDS CONSERVATION AREA
 - 5) EAST MOUNTAIN C.A. STUDY AREA INCLUDES:
 - a) ERAMOSA KARST CONSERVATION AREA
 - b) FELKER'S FALLS CONSERVATION AREA
 - c) MOUNT ALBION CONSERVATION AREA
 - d) CHIPPEWA RAIL TRAIL
 - 6) SALT FLEET C.A. STUDY AREA INCLUDES:
 - a) DEVIL'S PUNCHBOWL C.A.
 - b) DOFASCO 2000 TRAIL
 - c) VINEMOUNT CONSERVATION LANDS
 - d) WINONA CONSERVATION LANDS
 - 7) FIFTY POINT C.A. STUDY AREA



DATE: 2023/01/27

MASTER PLAN STUDY AREA MAP



HCA's 10 Year Master Plan Update Strategy was recently updated by staff and approved by HCA's Board of Directors in 2022. This Strategy applies to all properties that HCA owns and manages. As per this document, guidelines are set out for the completion of HCA Master Plans including Management Plans and Study Areas. This strategy notes that HCA lands that lie within the boundary of the Niagara Escarpment Plan will need Master Plan approval from the Niagara Escarpment Commission (NEC) for HCA to formally ratify them. Consequently, HCA strategically decided to develop all HCA Master Plans within the guidelines of the Niagara Escarpment Parks and Open Spaces System (NEPOSS), which is a requirement of the NEC for any public agency NEPOSS park Master Plans. The NEPOSS policy framework ensures HCA follows a consistent methodology for all plans, and the plans are developed to an appropriate level of detail with sufficient public consultation for all proposed land improvements and uses.

This Management Plan follows the NEPOSS planning manual, and with the information gathered in the natural heritage inventory, two land use zones are identified for Winona and Vinemount Conservation Areas. These zones are intended to help guide future planning, development, and management of the conservation areas. The zone boundaries are shown in more detail the appended Conservation Area Zone Maps.

Zones are intended to fulfill a variety of functions in the conservation areas, including the following as outlined in the current NEPOSS manual:

- Identification and recognition of the features and attributes (values).
- Protection of key natural heritage features and cultural heritage resources.
- Confirmation of the appropriate locations for activities (i.e. directing activities with higher impacts to the least sensitive areas and low impact activities to areas that are more sensitive, if appropriate).
- Delineation of areas based on their requirements for management (e.g. management plan objectives).
- Standardization to support management objectives and actions, based on values (e.g. Nature Reserve Zones supports protection of sensitive natural heritage features and cultural heritage resources).
- Balancing of public use with the preservation of the natural environment.

The two land use zones identified for Winona and Vinemount are:

- Natural Environment Zone
- Resource Management Zone

Natural Environment Zone

Natural environment zones include natural, cultural, and aesthetic landscapes in which minimum development is permitted to support low-intensity recreational activities. WVCA’s natural zones are primarily the wooded area below the escarpment brow.

Table 1. Natural Environment Zone

Zone	Description	Management Direction	Permitted Uses (subject to management planning)
Natural Environment	<p>Includes scenic landscapes in which minimum development is permitted to support recreational activities that have minimal impacts on the Escarpment environment.</p> <ul style="list-style-type: none"> ➤ Significant woodlands ➤ Devil’s Punchbowl Environmentally Significant Area (ESA) ➤ Niagara Escarpment Section Area of Natural and Scientific Interest (ANSI) 	<p>This zone may function as a buffer between Nature Reserve Zones and Development Zones, Cultural Heritage Zones.</p> <p>Management guidance should maintain and enhance the scenic resources and open landscape character of the environment.</p>	<p>Sustainable recreational activities that have minimal impact on the environment may be permitted.</p> <p>Examples include:</p> <ul style="list-style-type: none"> ➤ Bruce Trail ➤ Nature Appreciation from designated recreational trails and lookout stations ➤ Temporary scientific research ➤ Conservation practices (e.g. tree maintenance and monitoring, invasive species control, erosion control) <p>Infrastructure required for safety or accessibility may be permitted where there is no feasible alternative.</p>

Resource Management Zone

Resource management zones provide for sustainable resource management of agricultural lands, previously disturbed sites, forest products, and land that has a long-term resource agreement such as a managed forest.

WVCA’s resource management zones include the agricultural land and former parking area west of Eighth Road East.

Table 2. Resource Management Zone

Zone	Description	Management Direction	Permitted Uses (subject to management planning)
Resource Management	<p>Provides for sustainable resource management of forests, fisheries, watersheds, wildlife, or flood control. Previously disturbed sites (e.g. old farm fields, abandoned quarries) where active measures are being taken to re-establish natural vegetation.</p> <ul style="list-style-type: none"> ➤ Farmed field ➤ Fallow field ➤ Former parking area ➤ Farm pond 	<p>Management guidance should support:</p> <ul style="list-style-type: none"> ➤ Experimenting with alternative resource management practices. ➤ Understanding ecosystem structures and functions. ➤ Activating effective conservation and stewardship practices. 	<p>These areas may be used to demonstrate ecologically sustainable resource management practices.</p> <p>Examples may include:</p> <ul style="list-style-type: none"> ➤ Farmed fields ➤ Recreational trails ➤ Educational tours ➤ Rehabilitation / naturalization projects ➤ Wetlands ➤ Research <p>Recreation uses in this zone are subject to HCA policies and management planning.</p>

4.0 NATURAL AREA INVENTORY

4.1 Natural Features

These conservation lands protect one of the more extensive continuous Escarpment features in the Niagara Peninsula.

The geomorphology of the area contains fine examples of escarpment face, cliff foot talus/side scree slide scars, boulder strewn slopes and narrow sub-escarpment terraces which are somewhat intersected by intermittent stream valleys. Portions of the slopes have very well-developed bedrock-controlled shale terrace which is strongly dissected by valleys.

The area also contains some of the most mature and diverse vegetative species in the Niagara Section of the escarpment. Of particular significance is the excellent slope forest complex which presents a mature array of highly representative features such as forested talus slopes, lower slope forests and others. As well, there is a very well-developed terrace ridge and valley pattern of forests on the narrow sand and shale ridges, similar to those of the Short Hills area in Niagara, or the valley rim forests of the Iroquois Plain.



4.2 Biophysical Inventory Methodology

Biophysical inventories completed at Winona and Vinemount Conservation Areas were mainly restricted to flora, breeding birds and Ecological Land Classification. Surveys completed by HCA staff in 2021 and 2022 are noted in Table 3. Ecological Land Classification was completed across the entire property, excluding the farmed land and former parking area near Eighth Road East, and is shown on Maps 1 and 2 in Appendix 1. Species lists are included in Appendix 4. It is intended that once farming ceases on the lands, supplementary field reviews will be conducted to update the ELC mapping.

Table 3. Summary of Ecological Field Studies

Survey Type	Dates, Year	Day(s)
Floral Inventory	2021, 2022	Concurrent with ELC surveys
Breeding Bird Surveys	2021, 2022	June 3, June 10, June 21, June 30
Ecological Land Classification (ELC)	2021, 2022	May 12 2021, May 26, June 2, 3 10, 21 and 30, Sept 13, 21 and Oct 6 2022
Incidental Wildlife	Recorded when encountered during all visits – 2021 and 2022	

4.3 Ecological Land Classification

The Ecological Land Classification (ELC) system for Ontario was used to describe the vegetation communities at WVCA. Staff conducted multi-season inventories of the property in 2020-2021. Details on the canopy, sub canopy, shrub and ground layers of each vegetation community were recorded. Vegetation community boundaries were determined using air photo analysis and further refined in the field.

.1 Flora/ Botanical Inventory

Botanical inventories were conducted as a part of the Ecological Land Classification surveys of the property. Specific floristic inventories occurred in the fall of 2022 to further identify asters and goldenrod species as they bloom late in the season. An additional survey in the spring of 2021 was conducted for spring ephemerals (early spring flowers). Species in this group die back by mid-summer and therefore are missed when spring surveys are not conducted. Species nomenclature is based on the Natural Heritage Information Centre (NHIC) Plant Species list (updated yearly). Species and community ranks are determined provincially by the Ministry of Natural Resources and Forestry Natural Heritage Information Centre Database (Sfranks) and locally via the Hamilton Natural Areas Inventory (Schwetz 2014)



.2 Fauna Inventory

No specific surveys were conducted for wildlife on the property. All wildlife encounters were incidental while conducting other aspects of field work. These surveys involved general coverage recording all species observations and signs (e.g. tracks/trails, scat, and burrows, dens, browse and vocalizations). Background data including older survey material was used to develop a list of butterflies, mammals and dragonflies that have been recorded by naturalists in the WVCA over the last 10 years. A summary of the findings is in Appendix 4.

Frog call surveys were not conducted on this property due to the lack of suitable habitat.

.3 Breeding Bird Survey

Breeding bird surveys were conducted on June 3, 10, 21 and 30, 2022 and followed the Ontario Breeding Bird Atlas (Cadman 2010) methodology.

4.4 Ecological Land Classification Results

Field surveys occurred on May 12 2021, May 26, June 2, 3 10, 21 and 30, September 13, 21 and October 6, 2022. The subject property was delineated into 11 vegetation communities. Details on community classifications can be found in Appendix 1 on Maps 1 and 2.

.1 Flora/Botanical Inventory Results

Over the course of multiple survey dates including ELC surveys, staff identified 190 species of plants. Of these, 145 are considered native plant species (76%) while 45 are non-native species (24%) and there were an additional 17 species identified to genus only. The Hamilton NAI (HCA 2014) indicates that there are 1496 species of plants in the Hamilton-Wentworth jurisdiction. Plant species within the WVCA represent 13% of that regional flora.

The Floristic Quality Index (FQI) and the Native Mean Coefficient of Conservatism (CC) have been calculated for the entire property. The CC is a measure of the species specificity of habitat requirements, with a coefficient of 0 indicating a plant tolerant of a wide range of conditions and 10 indicating a plant that has the most specific habitat requirements. FQI is a measure of vegetation quality and is based on both the habitat fidelity of each species and species richness. The FQI for both of these conservation areas is 52.82 and the mean CC value is 4.39 (Table 4). These are considered moderate to high for FQI and mean CC. This is likely reflective of the rural nature of WVCA.

Table 4. Floristic Summary and Assessment

FLORISTIC SUMMARY & ASSESSMENT		
Species Diversity		
Total Species:		190
Native Species:		145
Exotic Species		45
Species ID'd to sp. only		17
Total Taxa in Region (NAI 2014)		1496
% Regional Taxa Recorded		13%
% Native species		76%
% exotic species		24%
Co-efficient of Conservatism and Floral Quality Index		
Co-efficient of Conservatism (CC) (average)		4.39
CC 0 to 3	<i>lowest sensitivity</i>	41
CC 4 to 6	<i>moderate sensitivity</i>	90
CC 7 to 8	<i>high sensitivity</i>	13
CC 9 to 10	<i>highest sensitivity</i>	1
Floral Quality Index (FQI)		52.82

4.5 Fauna Inventory Results

.1 Breeding Birds

Breeding bird surveys were conducted within the WVCA in the spring of 2022. These surveys identified 39 species of birds including the Eastern Wood-pewee (*Contopus virens*) which is at risk provincially and federally. Other notable species include the Yellow-billed Cuckoo (*Coccyzus americanus*), Hooded Warbler (*Setophaga citrina*), and Carolina Wren (*Thryothorus ludovicianus*), which are considered rare in the City of Hamilton.



Eastern Wood-pewee

Background data was also collected from the following sources, iNaturalist, Natural Areas Inventory, and eBird. Surveys in 2012 for the NAI identified an additional 46 bird species while eBird and iNaturalist identified an additional 37 species. These were mainly composed of spring and fall migratory species and hawks and owls. These combined data sources have identified 122 species in the area. Of these 9 are provincial or federal species at risk, 20 are locally rare and 34 are locally uncommon.

.2 Butterflies and Dragonflies

Surveys completed for the Natural Areas Inventory in 2012 identified 28 species of Lepidoptera, as well as 10 species of Odonata. One additional species of Lepidoptera was recorded in the area by incidental observation. Observations of Monarch Butterflies, a provincial species at risk occurred in 2012. Three of the butterfly species found in the NAI were locally uncommon. None of the odonatan were provincially or locally rare.

.3 Mammals

All incidental wildlife encounters were recorded while conducting other aspects of field work. Mammal sightings were also recorded during historical surveys conducted for the Natural Areas Inventory. Fourteen mammal species have been recorded for this area by staff and the Natural Areas Inventory. All mammal species recorded are common to the area.

.4 Herpetofauna

Incidental observations by field staff of herpetofauna include 4 different species; the American Toad (*Anaxyrus americanus*), Eastern Gartersnake (*Thamnophis sirtalis sirtalis*), Western Chorus Frog - Carolinian Population (*Pseudacris triseriata* pop. 2) and Red-spotted Newt (*Notophthalmus viridescens viridescens*). Historical survey data from the Natural Areas Inventory (2012) note an additional 13 species. This includes the Snapping Turtle (*Chelydra serpentina*), Jefferson Salamander and its associated complex (*Ambystoma jeffersonianum*) and Midland Painted Turtle (*Chrysemys picta marginata*) which are at risk provincially and federally. The Eastern Milksnake (*Lampropeltis triangulum*) is at risk federally.

4.6 Aquatic Inventory

The watercourses of these properties are intermittent in nature. Some begin as small waterfalls or cascades off the escarpment lip while most begin as groundwater seeps. They contribute to the Stoney Creek Numbered Watercourses 5, 6, 7, 9, and 12 (Fifty Creek). Some of the tributaries have sections with deeper gully erosion occurring in the steeper slope areas with the most notable area being the WC#6 features in the area of the Jones Rd. access. These headwater drainage conditions limit their significance on the properties where they occur to being indirect fish habitat. Though they still play an important role in contributing resources to the downstream habitats. Most of the watercourses are small enough that they are forded by tail users, with just a few having culverts or bridge crossings. The City also has road culverts and associated drainage infrastructure adjacent to and potentially extending onto the McNeilly and Fifty Road properties



4.7 Significant Ecological Features

Policies are in place through the City of Hamilton Official Plan and the Provincial Policy Statement to provide for the protection of significant ecological features from development. This section highlights key features and policies of the study area.

.1 Natural Heritage Designations

.1 Significant Woodlands

All of the properties within the Winona and Vinemount Conservation Areas are considered by the City to be significant woodland. Significant woodlands for the City means an area which is ecologically important in terms of features (species composition, age of trees and stand history) and function (contributes to the broader landscape because of its location, size or the amount of forest cover in the planning area) (City of Hamilton, 2019).

.2 Environmentally Sensitive Area

The Devil's Punchbowl Escarpment Environmentally Significant Area (ESA) includes the entire WVCA. The ESA was designated because it meets many of the 2003 ESA criteria including:

1. Significant Earth Science Feature
 - a. the area encompasses regionally significant landforms
2. Significant Ecological Function
 - a. the area contains significant species
 - b. the area contains rare biotic communities

- c. the riparian area serves as a link between natural areas along the Niagara Escarpment
- d. the area is representative of the natural features of the Niagara Peninsula section of the Niagara Escarpment

ESA areas are protected within the Rural Official Plan for the City of Hamilton. No new development or site alterations are permitted within or adjacent to ESA's unless it can be shown, through an Environmental Impact Statement (EIS) that there will be no negative impacts on the ecological features or functions of the ESA.

.3 Area of Natural and Scientific Interest (ANSI)

Both conservation areas are also part of the provincially significant Niagara Escarpment Section Life Science ANSI. This is one of the largest natural areas on the Niagara Peninsula and includes the talus and forest slopes from McNeilly Road to Regional Road 12 in Niagara. Within this section there are 9 km of moist cliff with extensive talus and clay loam forests of Sugar Maple/Black Maple/Red Elm below. There are a few drier ridges on HCA owed lands close to Fifty Road which support Red Oak forests. This area has a high diversity of plant and bird species and old growth forests.

From Fruitland to McNeilly Road is an additional Provincially Significant Life Science ANSI, Fruitland Escarpment. It has been designated because it is contiguous with the Niagara Escarpment Section ANSI and contributes 65 ha and forms part of a 13.6 km corridor from Hamilton to Niagara.

4.8 Biophysical Inventory – Analysis

.1 Species at Risk and Locally Rare Species

.1 Significant Flora

Butternut, federally and provincially endangered, was the only plant species considered provincially rare that was found in these conservation areas. There were only a few still surviving the Butternut canker. Of the plant species recorded on the subject lands through the 2020 and 2021 field surveys, one plant species was found to be locally rare, Goldie's Wood Fern by the City of Hamilton.

.2 Significant Fauna

The following 10 species recorded at WVCA listed in Table 5 are considered species at risk either federally (SARA) or provincially (ESA). These species were recorded within either Winona or Vinemount Conservation Areas through different data sources all observed during the breeding season except Eastern Whip-poor-will which was noted on migration.

Table 5. Federal and Provincial Species at Risk

Common name	Scientific name	SARA status (Schedule 1)	ESA status	Documented
Barn Swallow	<i>Hirundo rustica</i>	THR	SC	NAI
Bobolink	<i>Dolichonyx oryzivorus</i>	THR	THR	NAI
Eastern Whip-poor-will	<i>Antrostomus vociferus</i>	THR	THR	ebird
Wood Thrush	<i>Hylocichla mustelina</i>	THR	SC	BBS
Bank swallow	<i>Riparia riparia</i>	THR	THR	NAI
Chimney swift	<i>Chaetura pelagica</i>	THR	THR	NAI
Canada Warbler	<i>Cardellina canadensis</i>	THR	SC	NAI
Eastern Meadowlark	<i>Sturnella magna</i>	THR	THR	NAI
Jefferson Salamander and complex	<i>Ambystoma jeffersonianum</i>	END	END	NAI
Monarch	<i>Danaus plexippus</i>	END	SC	NAI

The Barn Swallow and Canada Warbler have been reassessed recently (2020) by the federal Committee on the Status of Endangered Wildlife in Canada (COSEWIC) to Special Concern. Neither status has been changed on Schedule 1 of SARA as of the writing of this Management Plan so they will be treated as SAR in this document.

Adult Monarchs have been observed throughout the fields and open portions of the forested habitats of this conservation Area. This species is considered a species of “Special Concern” on the Species at risk in Ontario (SARO) list. This means that the species lives in the wild in Ontario but may become threatened or endangered due to a combination of threats and biological characteristics. Many of these species at risk noted above are from background documents and their exact location within the WVCA is not known. It is likely that the Chimney Swift, Barn and Bank Swallows were seen flying over these conservation areas. The Eastern Whip-poor-will was seen on migration, while the Bobolink and Eastern Meadowlark may have been recorded in the large fields adjacent to these conservation areas. Although not surveyed for, it is likely that species at risk bats use the conservation areas for parts of their life cycle. Wood thrush was heard in multiple locations within the forested slopes of the Niagara Escarpment. Finally, the Jefferson Salamander records are from the Natural Areas Inventory and likely recorded in the forested talus slopes. This species has been included as it is cryptic species to survey for and it is long lived. Threatened and endangered species habitat is protected under the Endangered Species Act (provincially) and the Species at Risk Act (federally). Permits may be required for development within the habitat for threatened and endangered species.

There were also a large number of locally rare (23) and uncommon (38) species recorded during field surveys and found in the background research. The status for these species comes from the 2014 Natural Areas Inventory (NAI) document. These include birds, plants and butterflies and are mostly concentrated within the forested sections of the Niagara Escarpment. See Table 6. for more information.

Table 6. Locally Rare and Uncommon Species

Common Name	Scientific name	City of Hamilton Status	Source
Bald Eagle	<i>Haliaeetus leucocephalus</i>	Rare	iNat/eBird
Black-throated Green Warbler	<i>Setophaga virens</i>	Rare	iNat/eBird
Broad-winged Hawk	<i>Buteo platypterus</i>	Rare	iNat/eBird
Carolina Wren	<i>Thryothorus ludovicianus</i>	Rare	BBS
Clay-colored Sparrow	<i>Spizella pallida</i>	Rare	NAI
Common Raven	<i>Corvus corax</i>	Rare	iNat/eBird
Eastern Whip-poor-will	<i>Antrostomus vociferus</i>	Rare	iNat/eBird
Golden-crowned Kinglet	<i>Regulus satrapa</i>	Rare	iNat/eBird
Hooded Warbler	<i>Setophaga citrina</i>	Rare	BBS
Jefferson Salamander	<i>Ambystoma jeffersonianum</i>	Rare	NAI
Merlin	<i>Falco columbarius</i>	Rare	iNat/eBird
Northern Harrier	<i>Circus hudsonius</i>	Rare	iNat/eBird
Osprey	<i>Pandion haliaetus</i>	Rare	iNat/eBird
Peregrine Falcon	<i>Falco peregrinus</i>	Rare	iNat/eBird
Purple Finch	<i>Haemorhous purpureus</i>	Rare	iNat/eBird
Red-bellied Snake	<i>Storeria occipitomaculata</i>	Rare	NAI
Red-shouldered Hawk	<i>Buteo lineatus</i>	Rare	iNat/eBird
Ring-necked Pheasant	<i>Phasianus colchicus</i>	Rare	NAI
Sandhill Crane	<i>Antigone canadensis</i>	Rare	iNat/eBird
Sharp-shinned Hawk	<i>Accipiter striatus</i>	Rare	BBS
Yellow-billed Cuckoo	<i>Coccyzus americanus</i>	Rare	BBS
Alder Flycatcher	<i>Empidonax alnorum</i>	Uncommon	NAI
American Kestrel	<i>Falco sparverius</i>	Uncommon	NAI
American Redstart	<i>Setophaga ruticilla</i>	Uncommon	NAI
Belted Kingfisher	<i>Megaceryle alcyon</i>	Uncommon	iNat/eBird
Black-billed Cuckoo	<i>Coccyzus erythrophthalmus</i>	Uncommon	BBS
Blue-gray Gnatcatcher	<i>Polioptila caerulea</i>	Uncommon	NAI
Bobolink	<i>Dolichonyx oryzivorus</i>	Uncommon	NAI
Brown Creeper	<i>Certhia americana</i>	Uncommon	BBS
Chestnut-sided Warbler	<i>Setophaga pensylvanica</i>	Uncommon	BBS
Chimney Swift	<i>Chaetura pelagica</i>	Uncommon	NAI
Common Sootywing	<i>Pholisora catullus</i>	Uncommon	NAI
Compton Tortoiseshell	<i>Nymphalis l-album</i>	Uncommon	NAI
Cooper's Hawk	<i>Accipiter cooperii</i>	Uncommon	BBS
Eastern Bluebird	<i>Sialia sialis</i>	Uncommon	NAI
Eastern Meadowlark	<i>Sturnella magna</i>	Uncommon	NAI
Eastern Phoebe	<i>Sayornis phoebe</i>	Uncommon	iNat/eBird
Eastern Screech-Owl	<i>Megascops asio</i>	Uncommon	iNat/eBird
Herring Gull	<i>Larus argentatus</i>	Uncommon	NAI

Common Name	Scientific name	City of Hamilton Status	Source
Least Flycatcher	<i>Empidonax minimus</i>	Uncommon	NAI
Mourning Warbler	<i>Geothlypis philadelphia</i>	Uncommon	NAI
Nashville Warbler	<i>Oreothlypis ruficapilla</i>	Uncommon	iNat/eBird
Northern Mockingbird	<i>Mimus polyglottos</i>	Uncommon	NAI
Orchard Oriole	<i>Icterus spurius</i>	Uncommon	NAI
Purple Martin	<i>Progne subis</i>	Uncommon	NAI
Red-bellied Woodpecker	<i>Melanerpes carolinus</i>	Uncommon	BBS
Red-breasted Nuthatch	<i>Sitta canadensis</i>	Uncommon	iNat/eBird
Red-tailed Hawk	<i>Buteo jamaicensis</i>	Uncommon	BBS
Ruby-throated Hummingbird	<i>Archilochus colubris</i>	Uncommon	NAI
Scarlet Tanager	<i>Piranga olivacea</i>	Uncommon	NAI
Silvery Blue	<i>Glaucopsyche lygdamus</i>	Uncommon	NAI
Turkey Vulture	<i>Cathartes aura</i>	Uncommon	BBS
White-throated Sparrow	<i>Zonotrichia albicollis</i>	Uncommon	NAI
Winter Wren	<i>Troglodytes hiemalis</i>	Uncommon	BBS
Wood Thrush	<i>Hylocichla mustelina</i>	Uncommon	BBS
Yellow-throated Vireo	<i>Vireo flavifrons</i>	Uncommon	BBS

.3 Significant Wildlife Habitat

The Significant Wildlife Habitat Technical manual (Ontario 2000) along with the Eco regional criteria tables for Ecoregion 7E (OMNR 2015) were used to determine and define significant wildlife habitat (SWH) on the WVCA properties. Significant wildlife habitat includes broad categories of habitats for flora and fauna. SWH has been identified under the provincial policy statement for Ontario. No new development is allowed within identified portions of significant wildlife habitat unless there will be no negative impact to the form and function of this habitat type (see Section 4.7). The broad categories for significant wildlife habitat include seasonal concentration areas of animals, rare vegetation communities or specialized habitat for wildlife, habitats for species of conservation concern and animal movement corridors.

.4 Seasonal Concentrations of Animals

Seasonal concentrations of animals are areas where wildlife species occur annually in aggregations (groups) at certain times of the year (Ontario 2015). This can include single species concentrations or aggregations of multiple species.

.1 Land bird Migratory Stopover Areas

These are areas with woodlots or forests within 5 km of either Lake Ontario or Lake Erie that migratory birds, especially song birds, use as rest stops before or after crossing the great lakes during migration. Land Bird Migration should be studied in woodlots 2-5 Ha in size where woodlots are rare in the area of shoreline (Ontario 2015). Studies are needed to confirm the use of the habitat by > 200 birds/day and with > 35 species with at least 10 bird species recorded on at least 5 different survey dates (Ontario 2015). WVCA is within 5 km of Lake Ontario. HCA staff did not undertake migratory land bird studies on these

properties. It is assumed due to the position on the landscape, both the proximity to Lake Ontario and being some of the remaining forest stands that this area would function as migratory bird habitat. Migration occurs in the spring from April to May and then again from late July to October.

.2 Bat hibernation and Maternity Colonies

Although not surveyed, suitable habitat exists in these conservation areas for both bat hibernation caves and maternity colonies. There are cliffs and talus within these conservation areas that may support bat hibernation. There are also a number of snag trees within the forested communities that would support bat maternity colonies.

.3 Reptile Hibernaculum

This is a difficult type of significant wildlife habitat due to the cryptic nature of snakes. Ecology staff found three eastern garden snakes near a hole in the talus near Fifty Road. It is assumed this was a hibernaculum. There are likely others along the escarpment that went undetected.



Eastern Garter Snake

.5. Rare Vegetation Communities

These communities include areas that contain a provincially rare vegetation community, as defined by the NHIC and/or areas that contain a vegetation community that is rare within the planning area.

.1 Cliff and Talus Slopes

Cliff and talus slopes occur throughout these conservation areas. Cliffs are any vertical or near vertical rock that is greater than 3 m in height. While talus slopes are rock rubble at the base of the cliff. They are rare in the province and sensitive vegetation communities.



.6 Specialized Habitats of Wildlife

This is a community or diversity-based category as many species of wildlife require large areas of suitable habitat for successful breeding. The largest and least fragmented habitats within the planning area will support the most significant wildlife populations.

.1 Seeps and Springs

These are areas where groundwater comes to the surface and are often found within forested areas. The criteria include the presence of two or more seeps or springs. There

are many springs along the talus slope within the conservation areas. These areas are often used as water sources for wildlife in the winter when other water sources are frozen.

7 Habitat for Species of Conservation Concern and Rare Wildlife Species

Habitat for species of conservation concern includes wildlife that are listed provincially as species concern or are rare and declining. Table 7 provides a list of the seven species located within the WVCA. This list includes species seen flying over the WVCA such as Bald eagle and Peregrine Falcon. Eastern Wood Pewee was noted in several locations within the forested section of the Niagara Escarpment. Midland Painted Turtle, Eastern Milksnake and Snapping Turtle records come from the background materials. These species were likely recorded near small pools or agricultural ponds along the escarpment. Eastern Milksnake has been included even though it is considered special concern only nationally. This is a recognition that this is a cryptic species and its habitat should also be considered during any developments in the conservation area. Barn swallow, Canada warbler and Wood thrush could be included in Table 7 as well. In the writing of this plan even though these species are only considered special concern provincially, they will be treated as Species at Risk due to their federal status.

Table 7. Species of Conservation Concern

Common name	Scientific name	SARA status (Schedule 1)	ESA status	Source
Eastern Wood-Pewee	<i>Contopus virens</i>	SC	SC	2022
Bald Eagle	<i>Haliaeetus leucocephalus</i>	NAR	SC	eBird
Peregrine Falcon	<i>Falco peregrinus</i>	NAR	SC	eBird
Common Nighthawk	<i>Chordeiles minor</i>	SC	SC	BBS
Midland Painted Turtle	<i>Chrysemys picta marginata</i>	NAR	SC	NAI
Eastern Milksnake	<i>Lampropeltis triangulum</i>	SC	NAR	NAI
Snapping Turtle	<i>Chelydra serpentina</i>	NAR	SC	NAI

4.9 Natural Areas Recommendations

The natural habitat features at WVCA have been evaluated for restoration opportunities and invasive species removals. Restoration in certain areas can assist with buffering the natural habitats from the impacts of moderate to high levels of visitor use.

Priorities for natural areas conservation and restoration in this Management Plan are as follows:

1 Conservation Targets for Winona and Vinemount Conservation Areas (Nature Reserve Zone)

Biodiversity conservation targets are a limited number of species or ecological communities that ecologists select to represent the biodiversity of a protected area, and that therefore serve as the focus for conservation investment. Thus, conservation targets are simply those ecosystems, communities, or species upon which we focus planning and management efforts. Because we use only a handful of targets to plan for biodiversity conservation, selecting the appropriate suite of targets is crucial to successful conservation planning and adaptive management. A course filter/fine filter approach was used when analyzing and describing

conservation targets for WVCA. Conservation of existing forest and talus habitats and biodiversity is an important target for this WVCA. There are few impacts to the Sugar Maple forests, talus and cliffs. A very low level of invasive species was found and a diversity of species were recorded. These targets and issues were used to provide restoration and enhancement opportunities in the next section.

.2 Restoration/enhancement opportunities in the Nature Reserve, Natural and Resource Management Zones

The existing natural habitat features at WVCA have been evaluated for restoration opportunities. Restoration in certain parts of this property can assist with enhancing biodiversity and habitat resiliency for the forest and talus along the Niagara Escarpment. Priorities for natural areas restoration are as follows.

.1 Enhance biodiversity and long-term forest resiliency

The talus and forested slopes along the Niagara Escarpment are dominated by Sugar Maple. There is a very low diversity of other species within these forested areas. Butternut and White Ash used to form a canopy along with the Sugar Maple. These two species have been lost to invasive forest pest. In order to ensure these forests are resilient and stable in the long term it is recommended that a diversity of trees and shrubs be planted in these forests. Recommendations would include disease resistant butternut, shagbark and bitternut hickory, basswood and black walnut. To support this priority, this plan sets out capital budgets (see Appendix 2) for Natural Areas Restoration over the 10-year lifespan of this plan. This budget allows for HCA staff monitoring of the talus and forested slopes and to determine appropriate projects to enhance biodiversity. Outcomes of these management actions and further recommendations would be followed up on in the next scheduled Management Plan for WVCA.

.2 Stewardship with private landowners

These conservation areas form a narrow band of forest through an agricultural and rural landscape. The width of the forested communities is less than 300m wide and HCA generally owns only a portion of this area. Interior forest habitat does not exist within this area. This is reflected in the lack of interior forest birds breeding in these conservation areas. Increasing the width of these forested blocks will require work with adjacent private landowners to plant trees in the back portions of unused fields. This would also help add a buffer to these forests as local land uses change. Opportunities for HCA to acquire adjacent lands should also be explored with adjacent landowners, to help conserve the Escarpment habitat.

.3 Invasive species should be controlled

There are low levels of a number of invasive species located within these two conservation areas. As these populations are low this would be a great opportunity to control these species before large populations establish. To achieve this objective, an overall invasive species management plan should be developed for these Conservation Areas. More details on this restoration opportunity are outlined in Section 5.2.

5.0 CONSERVATION AREA MANAGEMENT

5.1 Land Management

Land management planning will be accomplished through adherence to the guidelines of the management zones noted in this plan, and through additional resource management plans developed by HCA as necessary. The overall intent will be to ensure protection and conservation of the significant natural areas noted as Natural Zones on the appended maps.

The ecological mapping and species data documented within this plan are provided as a baseline inventory to help guide future land management decisions and project planning. Where active management is required for a particular species, it will be accomplished through an HCA approved resource management strategy considering the guidelines outlined in this plan, and in accordance with policies of all governing agencies.

5.2 Vegetation Management

Additional non-native plant species will not be deliberately introduced into the conservation areas. Introduction of any new plant species by HCA will consider the biodiversity of the site, historical data of species present in the area, research, and additional relevant species inventories and contiguous surroundings within an approved restoration and stewardship strategy. In this plan “non-native” means species not native to Ontario as well as species native to Ontario but not to Hamilton. If established non-native plant species threaten natural heritage values, a program for their eradication will be developed subject to specific guidelines noted in the natural heritage inventory of this plan. An overall invasive species management plan should be developed for the conservation areas.

Invasive Species in Winona and Vinemount Conservation Areas

The species detailed below are a threat to the biodiversity and conservation values at WVCA. Trails throughout the conservation areas are movement pathways for a number of invasive species. The following section details the invasive species that occur in WVCA.

.1 Common Buckthorn

Common Buckthorn (*Rhamnus cathartica*) is a small tree or shrub that was introduced to Ontario from Eurasia. It was widely planted in farm hedgerows and fencerows as a wind break. It can survive in a wide range of conditions making it very good at invading a variety of habitats (Anderson, 2012). Birds and small mammals feed on the berries of this plant, which has caused it to spread. While the spread of this species is currently limited in the conservation areas, an effort will need to be undertaken to prevent future dominance of this species in the community. The focus should begin on all fruiting female trees. These fruiting females can be treated with herbicides and the remaining smaller stems removed through volunteer events and work days. The larger tree-like shrubs may require the cut-stump method of removal. Herbicide should be applied to fresh stumps or girdles or else the tree will re-sprout (Anderson, 2012). This species was low in number throughout the area, except near Fifty Road where

there are larger polygons of Common Buckthorn close to urban development.

.2 Phragmites

This species of common reed from Eurasia is a perennial grass. It is not clear how it was transported to North America. Phragmites (*Phragmites australis*) is an aggressive plant that spreads quickly and out competes other native species in wetland habitats (Nichols, 2020). It forms large mono cultures that decrease plant biodiversity and create poor habitat for wildlife.

There is currently a small population on HCA property off of Fifty Road. If there is enough water where the population is located (an excess of 30cm), an effective control strategy would include cutting and drowning of stems when water levels are highest in June. If water levels are not favourable for this strategy, pesticide application in the seasonal dry period (September/October) would be the best option (Nichols, 2020). A combination of these strategies can be employed to best suit the changing conditions within the patch. This population should be prioritized due to its small size which will make control easier and prevent spread into the surrounding community.

.3 Garlic Mustard

This species was introduced in the 1800's from Europe as an edible herb for early pioneers in the spring. It is a biennial plant that produces seed in its second year (Anderson, 2012). It can grow in a variety of conditions making it a very good invader in a variety of habitats. It easily outcompetes other native ground cover and can change the soil environments to favour its growth over others. Garlic Mustard (*Alliaria petiolata*) can be found throughout much of Vinemount Conservation Area along the Bruce Trail. Removal of this species is fairly straight forward with hand picking between April and June, before the plant goes to seed. With a dedicated effort over 5 years removal of this species can be achieved. Priority should be placed on the removal of second year plants.

.4 Greater Celandine

Greater Celandine (*Chelidonium majus*) was introduced to North America from Europe in the 1600s as a medicinal plant (Tree Canada, n.d.). It can grow in dense stands shading out any native diversity, and spreads readily by seed with the help of ants (Invasive Plant Atlas, n.d.). There is a small population of Greater Celandine currently growing in WVCA along the Bruce Trail. A toxic sap is released when any part of the plant is crushed that could be irritating to the skin and eyes. Therefore, if manual removal is chosen care should be taken by staff to don the appropriate personal protective equipment. It is likely plants will readily grow again from root fragments using manual removal, however this method could be used to limit the spread. In order to fully eradicate the species, it is likely the application of a systemic herbicide will be required to attack the roots of the plant (late fall or early spring) (Tree Canada, n.d.).

.5 Honeysuckle sp.

There are four main species of invasive Honeysuckle (*Lonicera*) in Ontario which can be difficult to identify due to their tendency towards hybridization, and the lack of identifying characteristics (flowers and fruits) throughout much of the field season (Tassie and Sherman, 2014). These plants have been brought to North America for three centuries from Europe and Asia as an ornamental. Invasive Honeysuckles can rapidly reproduce, grow quickly, and

outcompete beneficial vegetation including our native honeysuckles. Their fruits are attractive to birds and mammals, which aid their spread. Within WVCA, there are currently single plants along the Bruce Trails and small polygons throughout other sections of this property. While identification is easiest in the spring during bloom, hand pulling and weed wrenching smaller shrubs should be conducted in the fall as not to disturb the growth of any nearby spring ephemerals. Cutting and girdling larger shrubs should always be paired with the application of herbicide to newly exposed woody material to prevent excessive suckering come next season. Species identification in the spring should be prioritized to ensure only invasive honeysuckles are being treated.

.6 Dame's Rocket

This Eurasian biennial wildflower was introduced to North America in the 1600s and has since invaded many moist woodlands and open spaces (Johnson, 2010). The plant spreads through abundant seed production during its three month long blooming period. There is currently a small population of about 30 plants on the Bruce Trail just west of Fifty Road. Dame's rocket (*Hesperis matronalis*) can be pulled relatively easily from moist soil before the seeds mature in the spring. Alternatively, chemical herbicide can be applied in the late fall to rosettes over the course of a few years until the seed bank is depreciated (Johnson, 2010).

.7 European Privet

European Privet (*Ligustrum vulgare*) is a highly invasive ornamental shrub or small tree that is native to Europe, western Asia and northern Africa. It was introduced in the early 1800s, and has since colonized a range of different habitats due to its tolerance for a variety of soil types and environmental conditions (CABI, 2021). Plants may produce 10,000 fruits per tree, which are then spread by wildlife to seed in different areas. European Privet also reproduces vegetatively by its roots, so care must be taken not to spread root fragments during control efforts (CABI, 2021). Larger trees or ones difficult to manually remove can receive a basal spray of Garlon (Miller, 2003). There is currently a very small population of European Privet in WVCA. This population should be prioritized while it is still small and can more easily be eradicated before it becomes well established.

.8 Multiflora Rose

Multiflora Rose (*Rosa multiflora*) is a large perennial shrub that was introduced to North America in the late 1700s for horticultural purposes, and was widely promoted in the 20th century for a variety of uses (Warne, 2018). This plant grows quickly, can self pollinate, produce up to 500,000 seeds a year or more, and forms dense thorny thickets rapidly crowding out native biodiversity. Seeds are widely spread through animal's consumption of the plant's fruits, and can be viable in the seed bank for up to 20 years (Warne, 2018). Hand pulling is an effective control method for seedlings, however larger shrubs will aggressively re-sprout if cut without removing the roots. Therefore, a weed wrench and/or shovels should be used to fully remove the plant. This is a labour-intensive solution, and should prioritize small populations and sensitive areas. Alternatively, glyphosate-based chemical herbicide can be applied in late summer or early fall. A follow up-treatment may be required the following year, with ongoing monitoring to eliminate new seedlings (Warne, 2018).

One large plant has been identified in Vinemount Conservation Area west of Fifty Road. There were also a few scattered stems along the Bruce Trail. Removal or chemical treatment at this location should be prioritized as it can be more easily eradicated and prevent an established population while it is only an individual plant.

5.3 Fish and Wildlife Management

There is no direct fish habitat however the watercourses are still valuable as indirect fish habitat as they transport nutrients and sediment downstream. They should be protected in such a way that this important process is not disrupted.

For wildlife these lands act as refuge from the largely developed lands around them and as landscape linkages. As such populations should be protected from harvest and harassment on these properties.

For wildlife/human conflict HCA has developed the Hamilton Conservation Authority Wildlife Conflict Management Strategy. This strategy outlines the process and methods staff are to follow when dealing with any animal related issues within all conservation areas. This document was produced by the Hamilton Conservation Authority Wildlife Management Committee (WMC). The WMC was a special committee of the Hamilton Conservation Authority (HCA) that was established in May 2014 based on HCA staff recommendation and at the direction of the HCA Board of Directors. The purpose of the WMC was to develop best management protocols and practices for the management of wildlife on HCA lands.

If already established non-native species threaten the conservation area values, a program for their eradication may be developed if feasible and practical. Missing native species may be reintroduced, and existing populations replenished if feasible and acceptable to HCA.

5.4 Cultural Heritage Management

The following information from the 1979 Winona and Vinemount Master Plans is provided to supplement the property history noted in Section 3.2.

Vinemount is an area rich in history. The first European settlers were the United Empire Loyalists that arrived in the 1780's. E.D. Smith was a pioneer in the production of grapes, having set out vineyards in 1875 on a portion of Lots 7 and 8, concession 1V. Due to the introduction of the grape culture, the small community on the intersection of McNeilly Road and Regional Road 25 was given the name 'Vinemount'.

A house located just south of Ridge Road on the Eighth Road East, Stoney Creek (McNeilly Road) was built around the turn of the 20th century by E.D. Smith and Erland Lee. The building housed a creamery and cheese factory, later to become a spray plant for the fruit industry. The Women's Institute of Winona bought the building in 1928 for use as a meeting hall. Later the structure became the Vinemount Community Centre and has since been remodeled as a private dwelling.

A frame home built by the late Erland Lee on Ridge Road at Tapleystown Road is of provincial historical significance. The home was the site of the first meeting of the Women's Institute of Winona in 1905, the second such women's organization in the world. In 1896, the Toronto, Hamilton and Buffalo Railway was constructed providing rail service from Hamilton to Smithville, in southern Lincoln County. Vinemount was a stopover, but with the advent of the automobile, passenger train service decreased and Vinemount's popularity as a stopover declined.

There are no heritage designations for these conservation areas. However, the City of Hamilton Cultural Heritage Resources Inventory notes a number of properties nearby of heritage designation, historic value, or heritage interest. More historic research and study of the conservation areas is encouraged, to further promote knowledge and understanding about the property and the area cultural history.

Incompatible resource uses and recreational activities will be restricted or prohibited where necessary to protect cultural heritage resources. Any capital projects recommended for the property will require approval by the HCA Board of Directors, and may require approval from the City of Hamilton and the Niagara Escarpment Commission.

Archaeological studies have not been completed for the conservation areas. Archaeological studies in the surrounding area have demonstrated that this area of southern Ontario has been occupied by people as far back as 11,000 years ago as the glaciers retreated. More information is noted in HCA's Saltfleet Master Plan from archaeological assessments completed for the Saltfleet constructed wetlands.

Management strategies for any archaeological sites found in the future may range from allowing the sites to remain without interference, to research, excavation, and rehabilitation. Archaeological and historical artifacts may only be removed, and heritage landscapes altered, as part of an HCA approved cultural heritage research or management plan. Protection and management will be undertaken in consultation with all governing agencies and First Nations.

5.5 Agricultural

A small field is being actively farmed under a long-standing lease agreement with HCA. The field is on the Escarpment tableland at Ridge Road and McNeilly Road. See Appendix 1 for maps of the area.

HCA's long-term vision for active and formerly active agricultural fields is to see the land revert back to natural area. Active management to remove invasive species, along with restoration planting to enhance these lands is



recommended once farming stops. More detailed restoration plans will be required to implement restoration of these lands. HCA will consider restoration strategies when evaluating agricultural lease renewals.

5.6 Managed Forest

The nearest HCA managed forest parcel is the Vinemount Swamp, which is included within the Saltfleet Conservation Area Master Plan. The long-term objective of this plan is to sustain a healthy forest. Invasive species management and restoration projects to help naturalize these areas in support of this objective are noted in Section 4.9.

5.7 Conservation Area Operations

HCA will review the operation plan for these lands and provide staff with information and resources as required to operate the conservation areas on a day to day basis. This will include specific direction for the management and operation of all facilities and activities and address such topics as budgets, staffing, maintenance, enforcement and emergency services. The operation plan will be reviewed annually and updated as required.

Some disturbances to the area lands have been observed by HCA staff over time, including encroachment, unauthorized access (ATV trails), and dumping. The operation plan shall include monitoring of the lands to address these items as they occur. Individual volunteers and partner organizations may also assist in monitoring programs in the conservation areas as approved by HCA.

The HCA has the right to suspend operations of any facilities or services due to funding limitations, but in so doing will ensure that heritage values are not impaired and customer service standards are affected as little as possible.

New business practices may be introduced into the conservation areas' operations in accordance with HCA policy such as:

- Improving operating efficiency and controlling costs.
- Contracting out some operating functions.
- Improving customer service standards.

5.8 Research

HCA's properties provide, in essence, living laboratories for researchers. HCA staff monitor the health of lands using established protocols as well when needed can develop special research programs to answer resource related questions.

Potential research projects should focus on the natural areas to help guide HCA management efforts for:

- Enhancing forest biodiversity and long-term forest resiliency.
- Improving habitat for breeding birds in stewardship with land areas.
- Invasive species controls for Escarpment lands.

These projects would help support the natural areas recommendations noted in Section 4.9.

Outside Research by qualified individuals that contributes to the knowledge of natural and cultural history and to environmental and recreational management will be encouraged by HCA staff.

All research projects will require authorization from HCA. Authorization is obtained by contacting the staff ecologists who administer the process and issue letters of authorization or permission. This process would also extend to any other activities that could impact the ecological integrity of these lands.



6.0 MANAGEMENT PRACTICES

6.1 Natural Heritage Conservation

This Management Plan outlines priorities for natural areas conservation and restoration in recognition of the significant ecological features on these lands. As noted in Section 4.7, the conservation areas contain significant woodlands, environmentally sensitive areas, and Areas of Natural and Scientific Interest (ANSI). As noted in Section 4.8, the conservation areas also contain significant flora and fauna species, significant wildlife habitat, rare vegetation communities, and provincially rare cliff and talus slopes of the Niagara Escarpment. Accordingly, HCA supports the recommendations noted in Section 4.9 for natural areas conservation and restoration in this Management Plan, notably:

- Conservation targets for the Natural Zones shown on the appended maps.
- Enhancing biodiversity and long-term forest resiliency.
- Stewardship with area landowners to add natural buffer for the forest habitat.
- Control of invasive species.
- Conversion of agricultural/cultivated lands to natural area.

6.2 Water Management

Water crossings of the Bruce Trail are not considered to be navigable under the Federal Navigation Protection Act (formerly the Navigable Waters Protection Act), thus crossings do not have to provide for navigation.

Under current use the mix of the stream channel crossings is currently sustainable however if traffic on the trails increases there will be a need to formalize more of the forded crossings to structured ones such as bridges to prevent degradation of the stream channels and banks.

Significant gully erosion of some of the WC#6 tributaries in the area of Jones Road, could impact trail use and location in this area. Given HCA does not own any of the table lands that contribute to these channels we are limited in options to try and reduce this erosion. This section of trail should be monitored.

No new trail development is proposed that could adversely affect water resources. Should installation or replacement of culverts, bridges and boardwalk features for water crossings be required, HCA will adhere to federal, provincial and local policies and regulations and any proposed project will be reviewed internally by HCA Ecologists. See Section 4.0 for more information.

6.3 Conservation Area Experiences

HCA acquired these lands on the Niagara Escarpment because of their environmental significance and the overall role they play in the health and natural heritage of the watershed. These properties will continue to remain protected natural areas under HCA control and management.

Public access into WVCA is via the Bruce Trail. Property access off trail is only permitted for approved research, see Section 5.8 for more information.

Recreational activities are monitored by HCA and activities may be restricted or prohibited to protect the property, natural resources, and for public safety. During preparation of this plan HCA set up trail counters to monitor the number of visitors entering the conservation areas.

More information on the trail counts can be found in Appendix 3. HCA's trail counter recorded consistent monthly use of the Bruce Trail from May to September. In October, trail visitation doubled with the Thanksgiving holiday and peak of fall colour in this month. Attendance on weekends is typically double over weekdays, with the majority of visitors on the trail mid-day (10am – 3pm).



No visitor parking is provided by HCA for these lands. When offsite parking is found to be causing traffic and safety issues, HCA will enlist the assistance of municipal agencies for traffic control. Traffic control will be evaluated on a case by case basis by all agencies involved. Should this be a persistent problem HCA will work with municipal partners on traffic and visitor management strategies and solutions.

Due to the sensitive nature of the lands, motorized recreational activities are not permitted, with the exception of HCA approved service vehicles and emergency service (EMS) units.

The following recreational activities are currently permitted in the conservation areas:

- Hiking
- Nature Appreciation (from trails and designated lookout stations)

To protect the resource and provide a safe recreational experience for all visitors, the following recreational activities are not permitted:

- Cycling
- Horse Riding
- Winter Snowshoeing, Cross Country Skiing
- Unmanned Aerial Vehicle (Drones)
- All-terrain vehicles
- Motor bikes
- Snowmobiling

Approved research activities may be exempt from these restrictions, see Section 5.8.

6.4 Education and Environmental Awareness

HCA encourages further research to provide interpretive and educational information on the natural features and history of this area. Additional signage and rest areas are not anticipated to be required for the trail, however digital opportunities to promote and describe the trail and its features are offered by the Bruce Trail Conservancy. HCA provides online information about the significance of these natural areas and their need for protection. As HCA updates and develops new park-related brochures, maps and interpretive materials for this conservation area, the Escarpment's status as a World Biosphere Reserve should be recognized, as well as these public lands being within NEPOSS and including a portion of the Bruce Trail. Developing visitors' awareness and appreciation of Ontario's natural and cultural heritage, and fostering a commitment to protect that heritage for all generations is supported in the goals and objectives of this plan.

6.5 Public Infrastructure – Utilities, Trails and Transportation

It is recognized that public infrastructure exists and has historically altered lands in the study area. This section is intended to provide guidance for future HCA management of this land use.

Public infrastructure such as utility corridors (watermains, storm and sanitary sewers, natural gas or oil pipelines, hydro and communication corridors), trails (footpaths, boardwalks) and transportation links may cross WVCA lands. These uses may also have associated rights-of-way, land use agreements, licenses of occupation, permits etc. that are to be considered in the management of the ecological preserve and when implementing items from this Management Plan.

When new public infrastructure projects are proposed within conservation area owned lands, such uses will be subject, but not limited to, the following criteria:

- The need for the project, area of construction disturbance, and potential site disruption such as soil erosion, flooding, and vegetation loss.
- To maintain or where possible improve or restore key ecological linkages, habitat, and wildlife movement corridors.
- The potential public benefits of the project for research, education, or recreation.

HCA may require detailed environmental assessments, studies, and resource management plans in order to support such land uses.

6.6 Management Guidelines

.1 Permitted Uses

In addition to Section 6.3, leashed dogs are permitted on this portion of the Iroquoia Section of the Bruce Trail. Unleashed dogs anywhere on the Bruce Trail can lead to strained relations with neighbouring landowners. HCA and The Bruce Trail Conservancy review permitted trail uses together, and activities such as dog walking may be banned at their discretion.

.2 Restricted Uses

In addition to the restrictions noted in Section 6.3, no open fires or camping are permitted. Hunting and trapping are not permitted. Foraging is not permitted.

.3 Agreements

HCA has an agreement with The Bruce Trail Conservancy to manage this portion of the Bruce Trail in the conservation area. The HCA may enter into other management agreements to assist with specific management items in the conservation area. HCA values the support from area residents and landowners, businesses, service clubs and volunteer organizations that currently or could contribute in a variety of ways. The HCA will continue to nurture existing support and seek out new opportunities for community partnership agreements.

6.7 Maintenance Guidelines

.1 Bruce Trail Maintenance

The Bruce Trail Conservancy oversees a trail maintenance volunteer program to maintain the Bruce Trail. The program is administered through the Iroquoia Club Trail Development and Maintenance Director, and trail maintenance volunteers. Volunteers visit the property at least twice a year, complete annual reports on the conditions of the property, provide input into stewardship plans, and help with volunteer activities such as maintaining trail blazes and signs, trail clearing and maintenance, and removing garbage.

.2 Conservation Area Maintenance

.1 Vegetation Clearing

Vegetation is only to be removed on the Bruce Trail to ensure safe sight lines, reduce hazards and encroachment onto the trail. Any vegetation clearing beyond the trail is subject to review by HCA. Best management practices are to be followed so that maintenance activities, equipment and tools do not spread invasive species.

Trees and brush may be cut and pruned only to enable resource management as supported by this plan, to ensure public safety, and service easements (utility corridors) subject to specific service agreements. Trees and brush cut will be left to deteriorate naturally as close as possible to where they have been felled, or if that is not feasible, may be chipped and used (not on the trails) by HCA in other conservation areas.

Chemical fertilizers, herbicides, pesticides and suppressants will not be used for any vegetation management purpose except: insect and disease control under conditions set out in this plan; and eradication of non-native species where it has been demonstrated other methods are not feasible.

.2 Fencing

Boundary fencing may be considered to protect sensitive ecological areas from public access, for research purposes, or for public safety. Boundary fencing will be maintained by HCA, along with the appropriate signage.

.3 Lighting

The trail will not be lit and is intended to only be open sunrise to sunset.

.4 Garbage Collection

Garbage cans will not be provided. Trail users are expected to practice “pack in-pack out” trail etiquette.

.5 Washrooms

No washrooms are provided along the trail. Information signs may be used to direct trail users to conservation area parking areas and washrooms.

.6 Winter Maintenance

There will be no snow removal along the trail.

.7 Signage

Five types of signs are permitted along the trail: information, designation/direction, regulatory, warning, and interpretive. All signs are to follow the partners sign standards.

Information signs are intended to provide general information about the trail, identify the trail and may include a map.

Designation and direction signs are for wayfinding and may include maps for orientation. These signs are to be placed at trail heads and entry points and at trail nodes. Entrance signs, map boards, blazes, and trail post markers are some examples of this type of signage.

Regulatory signs are to be placed at roads. Warning signs are to be placed where there are anticipated safety concerns. Municipal traffic signs are an example of this type of signage.

Interpretive signs are intended to provide educational information on the site features and history of the area. Memorial plaques are an example of this type of signage.

.8 Watercourses

Trail maintenance at watercourse crossings is to be reviewed by both HCA and the Bruce Trail Conservancy. This requirement includes reviewing features such as culverts, boardwalks, bridges, and associated structures before maintenance work proceeds. Also, monitoring of the lands for gully erosion and mitigation/rehabilitation plans be considered and with adjacent landowners.

.9 Invasive Species

Invasive species removal is recommended as high priority, especially where the ESA's could be threatened. A separate and more detailed invasive species management plan is recommended in order to plan and prioritize this work.

7.0 SUMMARY

7.1 Implementation Priorities

Winona and Vinemount Conservation Areas are unique natural areas with environmentally sensitive lands. The overall intent of this Management Plan is to ensure protection and conservation of the natural areas, while allowing visitors passive day use recreation opportunities walking through the area on the Bruce Trail.

Continued safe enjoyment of the Bruce Trail requires on-going maintenance. HCA will continue to work with the Bruce Trail Conservancy in support of this goal.

A Capital Development Priorities budget is included in Appendix 2 to help HCA budget over the life of this plan the necessary activities to achieve these management goals. In summary, the following priority items are recommended to be implemented for the life of this Management Plan:

.1 Environmental Management:

An overall invasive species management plan should be developed for the Conservation Area, as well as a monitoring program to examine the effectiveness of management directions and activities described in Sections 4 to 6 of this plan. See Section 4.9 Natural Areas Recommendations for more information on these management goals:

- Enhancing biodiversity and long-term forest resiliency.
- Stewardship with area landowners to add natural buffer for the forest habitat.
- Control of invasive species.

.2 Trail Maintenance:

Conduct maintenance inventory to assess annual requirements for trail clearing, surfacing and condition reviews. Provide design and maintenance recommendations to the Bruce Trail Conservancy.

.3 Signage Replacements:

Signs are to be replaced by HCA and the Bruce Trail Conservancy in priority sequence to ensure public safety. The Niagara Escarpment Parks and Open Space System (NEPOSS) program logo may also be used on park signage and literature to identify these conservation lands within NEPOSS.



8.0 APPENDIX CONTENTS

1. Mapping
2. Capital Development Priorities
3. Trail Counter Data
4. Species Inventories
5. References

APPENDIX 1

Mapping

Map 1	Winona Conservation Area ELC
Map 2	Vinemount Conservation Area ELC
Map 3	Niagara Escarpment Plan Area
Map 4	Winona Conservation Area Zones
Map 5	Vinemount Conservation Area Zones

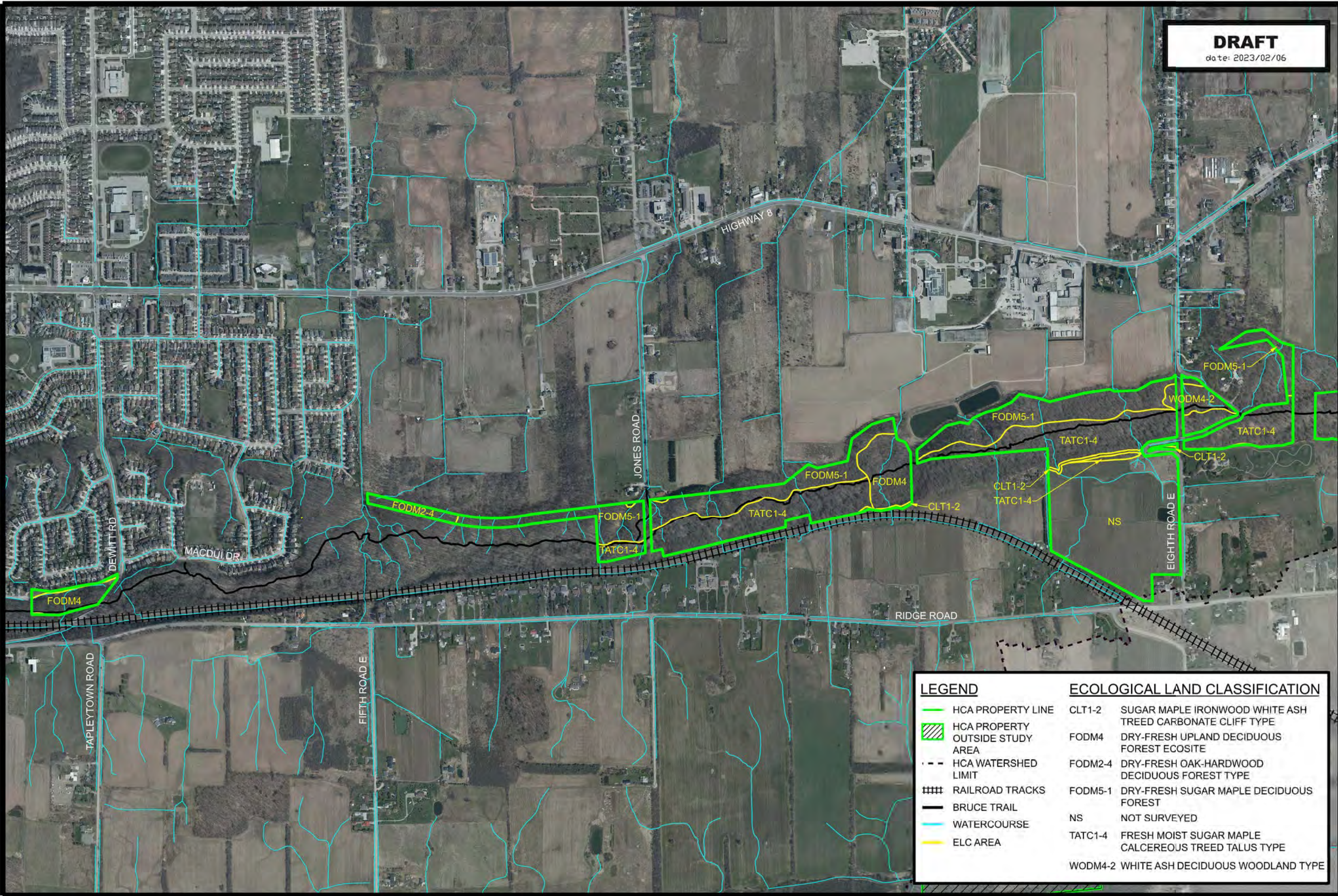
This page intentionally left blank.

DRAFT
date: 2023/02/06



**ECOLOGICAL LAND CLASSIFICATION
WINONA & VINEMOUNT C.A. MANAGEMENT PLAN**

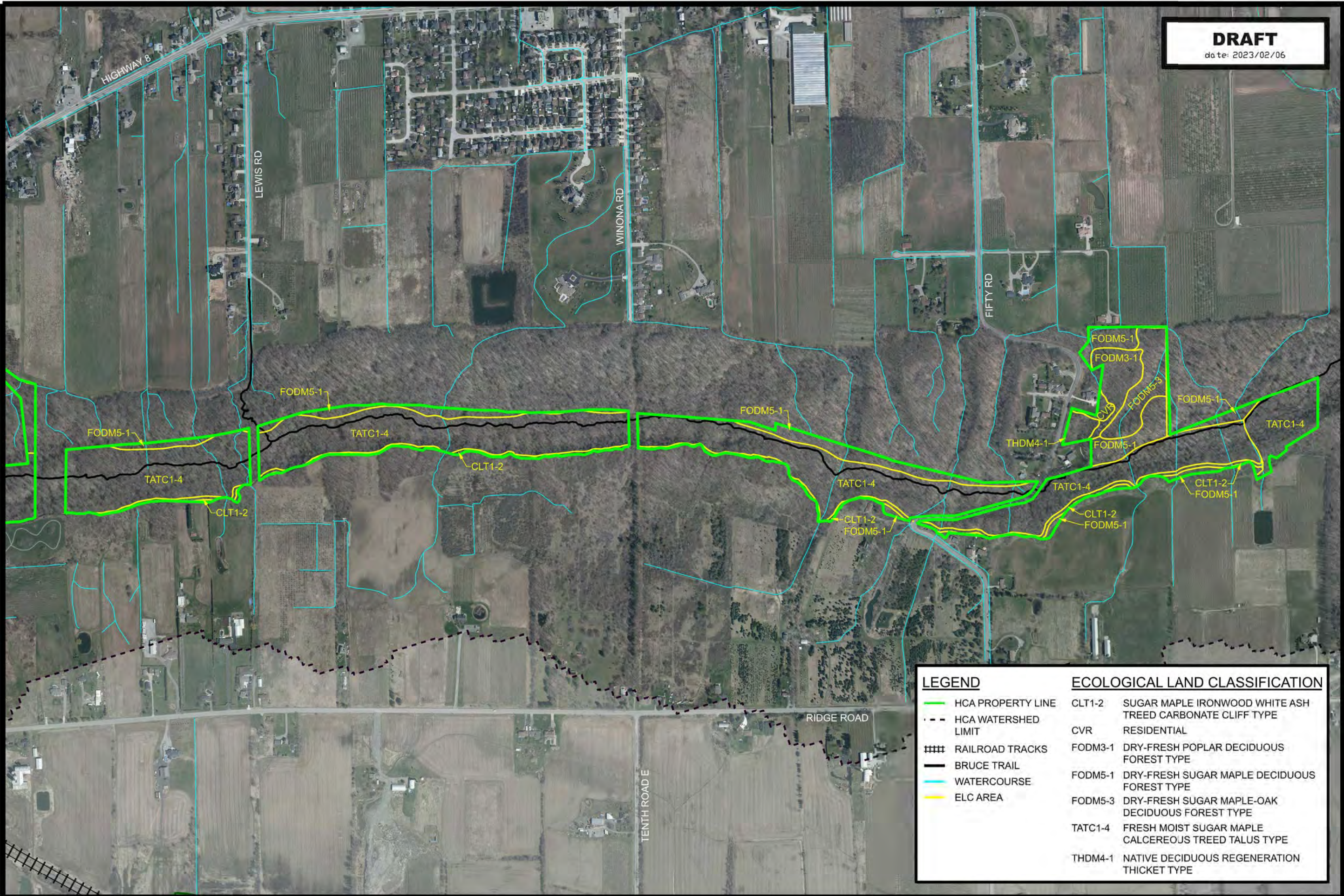
DATE: 2023/02/06



LEGEND		ECOLOGICAL LAND CLASSIFICATION	
	HCA PROPERTY LINE	CLT1-2	SUGAR MAPLE IRONWOOD WHITE ASH TREED CARBONATE CLIFF TYPE
	HCA PROPERTY OUTSIDE STUDY AREA	FODM4	DRY-FRESH UPLAND DECIDUOUS FOREST ECOSITE
	HCA WATERSHED LIMIT	FODM2-4	DRY-FRESH OAK-HARDWOOD DECIDUOUS FOREST TYPE
	RAILROAD TRACKS	FODM5-1	DRY-FRESH SUGAR MAPLE DECIDUOUS FOREST
	BRUCE TRAIL	NS	NOT SURVEYED
	WATERCOURSE	TATC1-4	FRESH MOIST SUGAR MAPLE CALCEREOUS TREED TALUS TYPE
	ELC AREA	WODM4-2	WHITE ASH DECIDUOUS WOODLAND TYPE



DRAFT
date: 2023/02/06



LEGEND		ECOLOGICAL LAND CLASSIFICATION	
	HCA PROPERTY LINE	CLT1-2	SUGAR MAPLE IRONWOOD WHITE ASH TREED CARBONATE CLIFF TYPE
	HCA WATERSHED LIMIT	CVR	RESIDENTIAL
	RAILROAD TRACKS	FODM3-1	DRY-FRESH POPLAR DECIDUOUS FOREST TYPE
	BRUCE TRAIL	FODM5-1	DRY-FRESH SUGAR MAPLE DECIDUOUS FOREST TYPE
	WATERCOURSE	FODM5-3	DRY-FRESH SUGAR MAPLE-OAK DECIDUOUS FOREST TYPE
	ELC AREA	TATC1-4	FRESH MOIST SUGAR MAPLE CALCEREOUS TREED TALUS TYPE
		THDM4-1	NATIVE DECIDUOUS REGENERATION THICKET TYPE

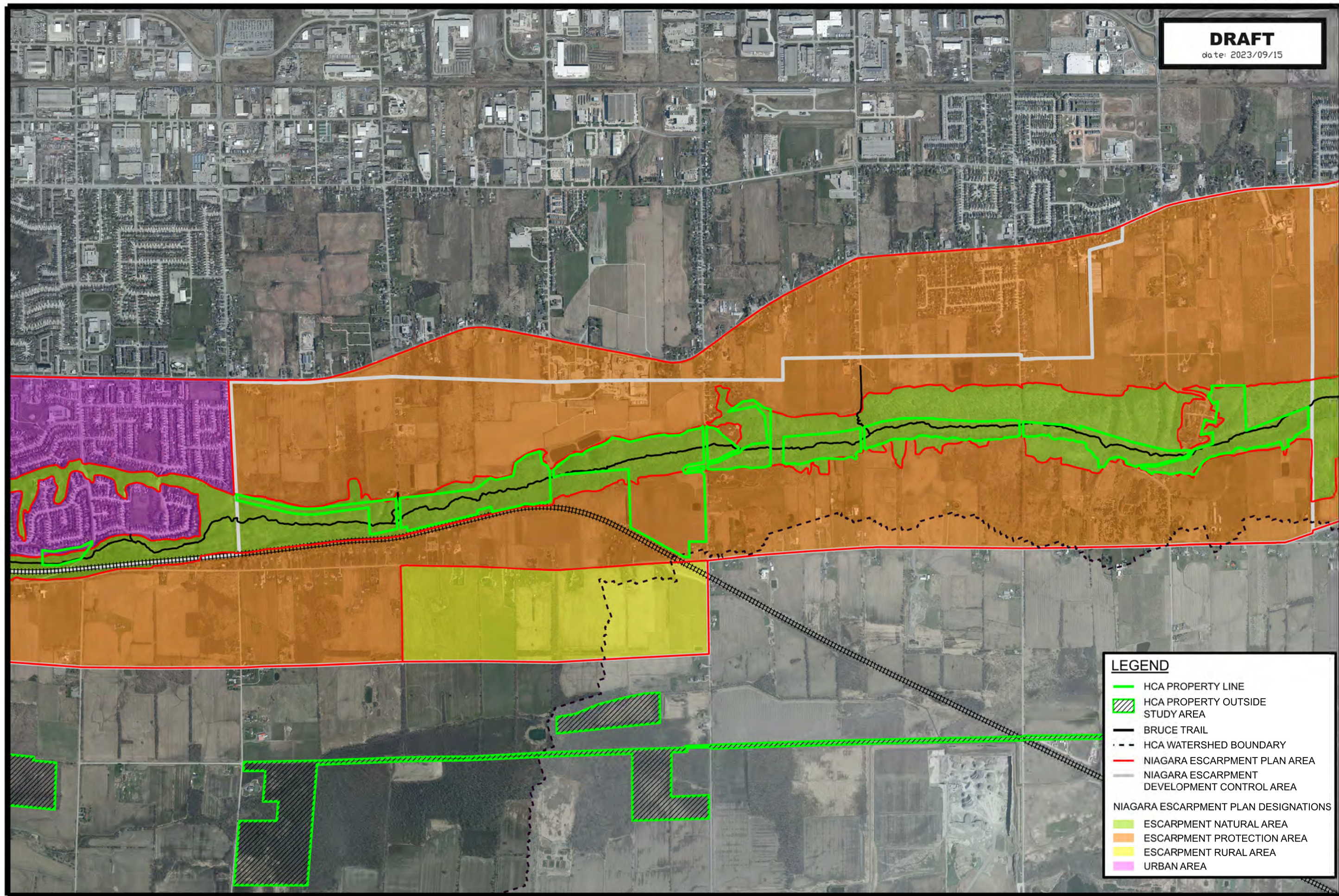
**ECOLOGICAL LAND CLASSIFICATION
WINONA & VINEMOUNT C.A. MANAGEMENT PLAN**

DATE: 2023/02/06



A Healthy Watershed for Everyone

DRAFT
date: 2023/09/15



LEGEND

- HCA PROPERTY LINE
- HCA PROPERTY OUTSIDE STUDY AREA
- BRUCE TRAIL
- HCA WATERSHED BOUNDARY
- NIAGARA ESCARPMENT PLAN AREA
- NIAGARA ESCARPMENT DEVELOPMENT CONTROL AREA

NIAGARA ESCARPMENT PLAN DESIGNATIONS

- ESCARPMENT NATURAL AREA
- ESCARPMENT PROTECTION AREA
- ESCARPMENT RURAL AREA
- URBAN AREA

**NIAGARA ESCARPMENT PLAN AREA
WINONA & VINEMOUNT C.A. MANAGEMENT PLAN**

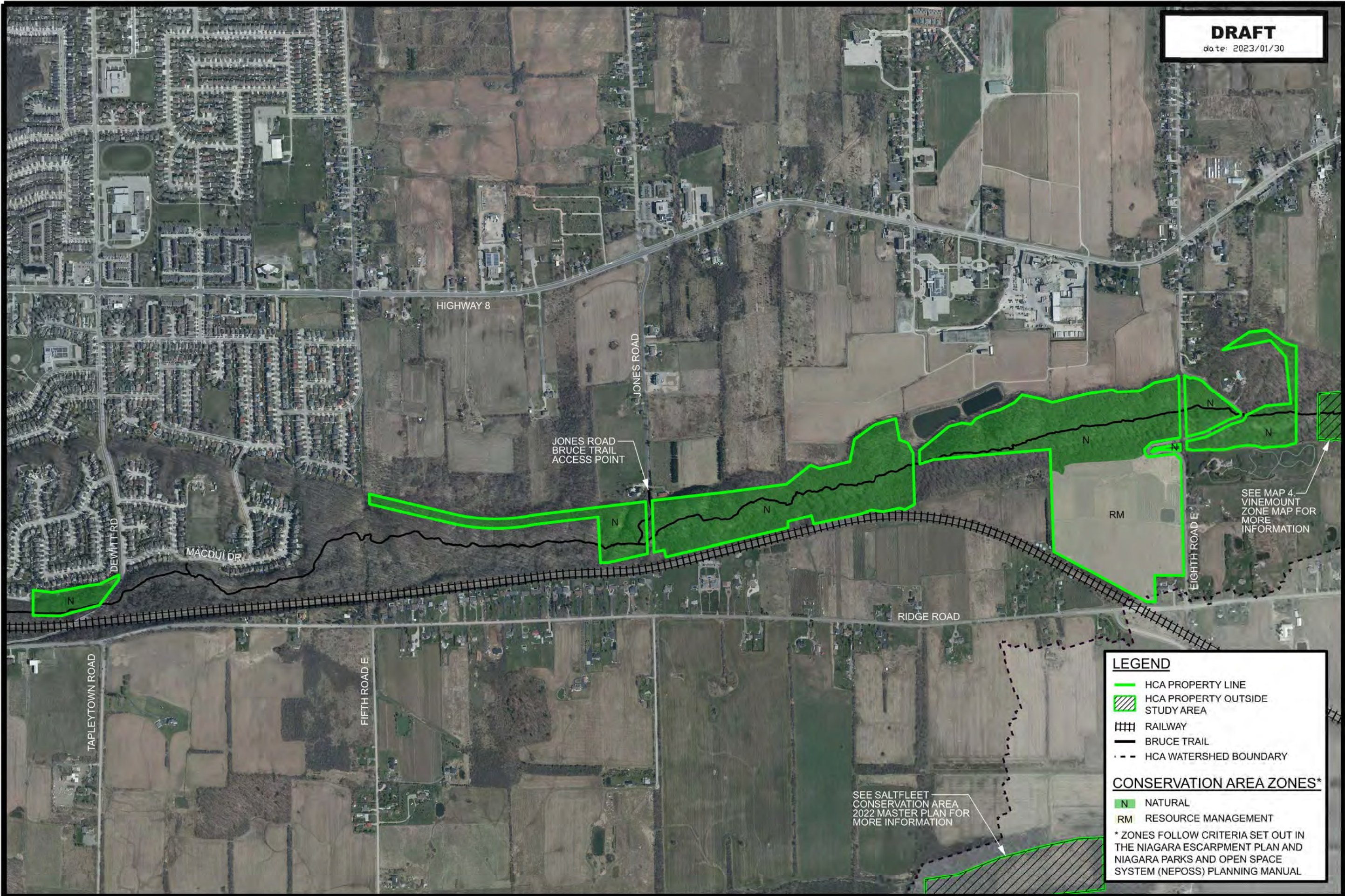
DATE: 2023/09/15



DRAFT
date: 2023/01/30



WINONA CONSERVATION AREA ZONES
WINONA & VINEMOUNT C.A. MANAGEMENT PLAN
DATE: 2023/01/30



LEGEND

- HCA PROPERTY LINE
- HCA PROPERTY OUTSIDE STUDY AREA
- RAILWAY
- BRUCE TRAIL
- HCA WATERSHED BOUNDARY

CONSERVATION AREA ZONES*

- N NATURAL
- RM RESOURCE MANAGEMENT

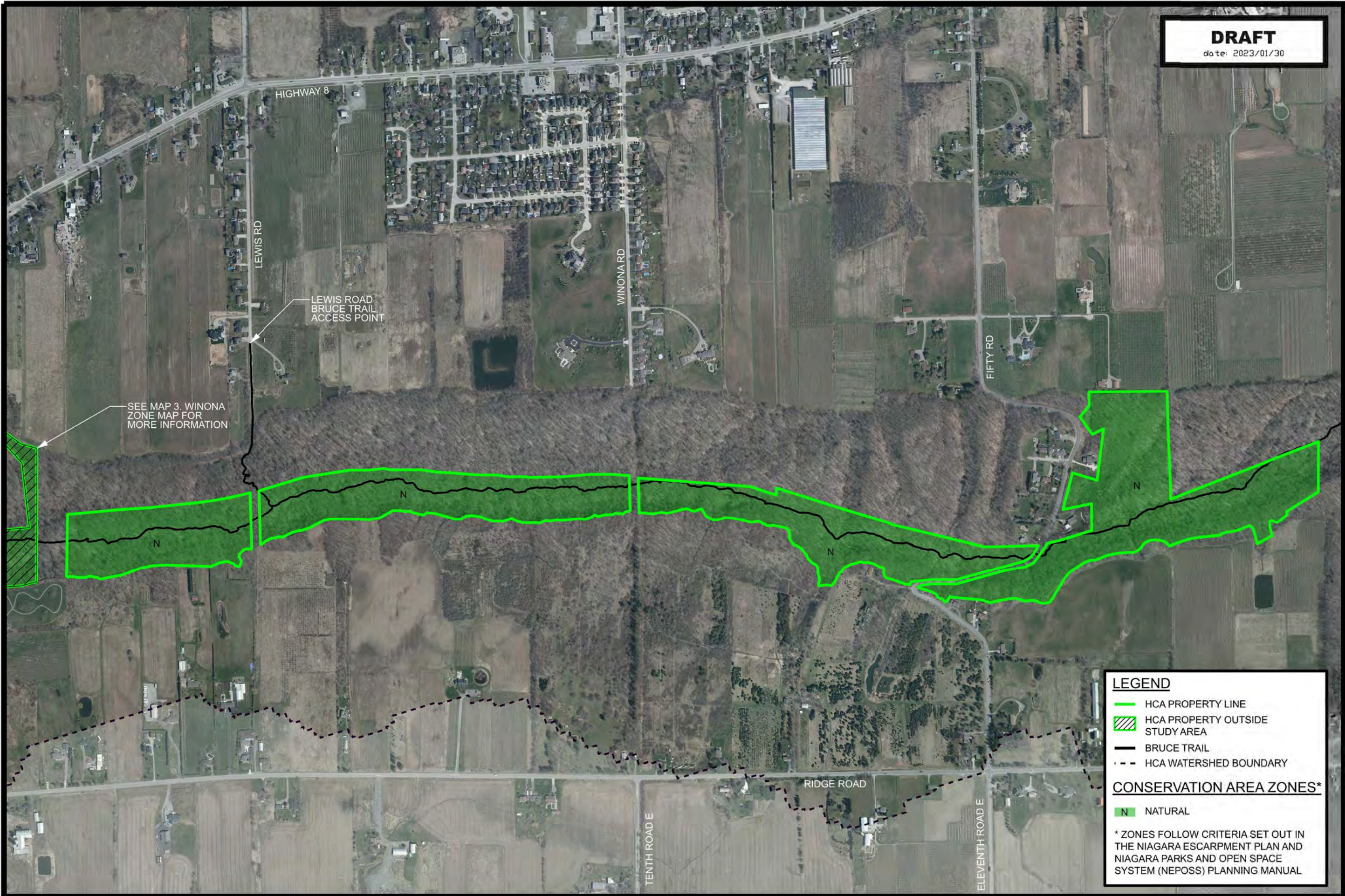
* ZONES FOLLOW CRITERIA SET OUT IN THE NIAGARA ESCARPMENT PLAN AND NIAGARA PARKS AND OPEN SPACE SYSTEM (NEPOSS) PLANNING MANUAL



DRAFT
date: 2023/01/30



VINEMOUNT CONSERVATION AREA ZONES
WINONA & VINEMOUNT C.A. MANAGEMENT PLAN
DATE: 2023/01/30



LEGEND

- HCA PROPERTY LINE
- HCA PROPERTY OUTSIDE STUDY AREA
- BRUCE TRAIL
- HCA WATERSHED BOUNDARY

CONSERVATION AREA ZONES*

- NATURAL

* ZONES FOLLOW CRITERIA SET OUT IN THE NIAGARA ESCARPMENT PLAN AND NIAGARA PARKS AND OPEN SPACE SYSTEM (NEPOSS) PLANNING MANUAL

This page intentionally left blank.

Capital Development Priorities

DRAFT – WINONA & VINEMOUNT CAPITAL PRIORITIES: 2022 - 2032

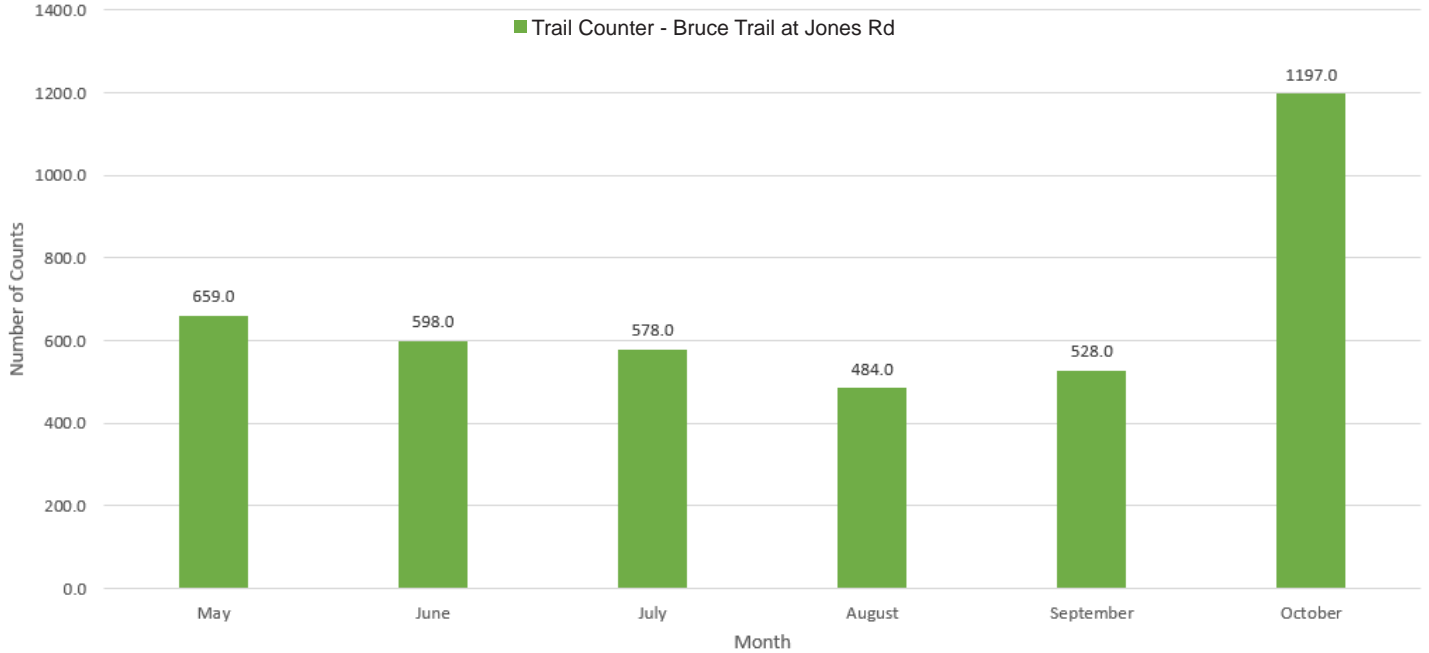
A. <u>Conservation Area Improvements</u>	*Budget (72.5K)
A1+ Invasive Species Management	\$ 50,000
A2+ Natural Areas Restoration	\$ 20,000
A3 Signage	\$ 2,500

* Budget costs are in 2022 dollars, projects and budgets to be reviewed annually.
 + Costs subject to ecological findings and recommendations.

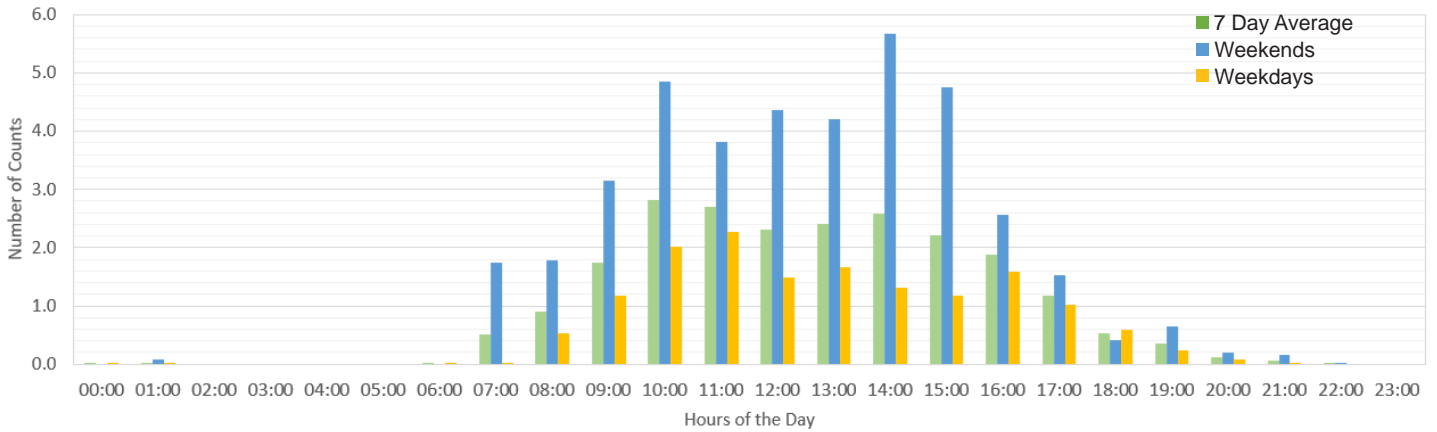
Trail Counter Data

Trail Counter Summary

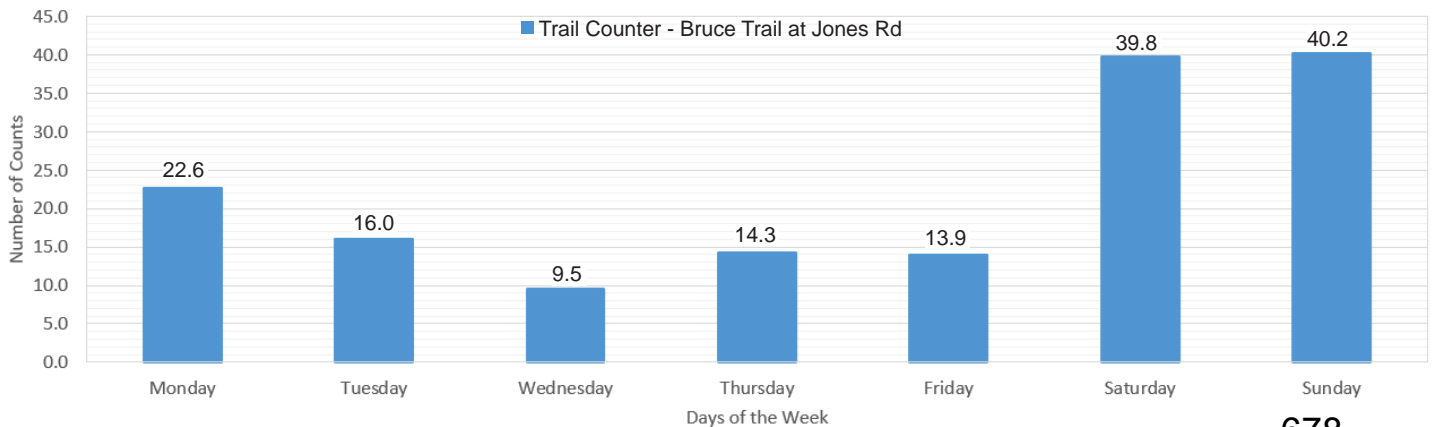
Trail Counter (Bruce Trail at Jones Road) - Monthly Totals 2022



Bruce Trail Counter - 24 Hour Average



Bruce Trail Counter - Average Count by Day for 2022



Natural Areas Inventory – Species List

- Appendix 4.1 Plant Species
- Appendix 4.2 Bird Species
- Appendix 4.3 Mammal Species
- Appendix 4.4 Butterflies and Dragonflies
- Appendix 4.5 Amphibians and Reptiles

Plant Species Inventoried in Winona and Vinemount Conservation Areas

ALL	SPECIES_CODE	SCIENTIFIC_NAME_NHIC	COMMON_NAME_NHIC
x	P-ACENEGU	<i>Acer negundo</i>	Manitoba Maple
x	P-ACESANI	<i>Acer nigrum</i>	Black Maple
x	P-ACEPLAT	<i>Acer platanoides</i>	Norway Maple
x	P-ACERUBR	<i>Acer rubrum</i>	Red Maple
x	P-ACESASA	<i>Acer saccharum</i>	Sugar Maple
x	P-ACESPIC	<i>Acer spicatum</i>	Mountain Maple
x	P-ACHMILL	<i>Achillea millefolium</i>	Common Yarrow
x	P-ACTPACH	<i>Actaea pachypoda</i>	White Baneberry
x	P-ACTRUBR	<i>Actaea rubra</i>	Red Baneberry
x	P-ADIPEDA	<i>Adiantum pedatum</i>	Northern Maidenhair Fern
x	P-EUPRUGO	<i>Ageratina altissima</i> var. <i>altissima</i>	Common White Snakeroot
x	P-AGR_SP	<i>Agrimonia</i> sp.	Agrimony Species
x	P-AGRSTRI	<i>Agrimonia striata</i>	Woodland Agrimony
x	P-ALLPETI	<i>Alliaria petiolata</i>	Garlic Mustard
x	P-ALLTRIC	<i>Allium tricoccum</i>	Wild Leek
x	P-AMELAEV	<i>Amelanchier laevis</i>	Smooth Serviceberry
x	P-ARCLAPP	<i>Arctium lappa</i>	Great Burdock
x	P-ARITRTR	<i>Arisaema triphyllum</i> ssp. <i>triphyllum</i>	Jack-in-the-pulpit
x	P-ASACANA	<i>Asarum canadense</i>	Canada Wild-ginger
x	P-ASPOFFI	<i>Asparagus officinalis</i>	Garden Asparagus
x	P-BARVULG	<i>Barbarea vulgaris</i>	Bitter Wintercress
x	P-BERTHUN	<i>Berberis thunbergii</i>	Japanese Barberry
x	P-BETPAPY	<i>Betula papyrifera</i>	Paper Birch
x	P-BIDFRON	<i>Bidens frondosa</i>	Devil's Beggarticks
x	P-CARCONC	<i>Cardamine concatenata</i>	Cut-leaved Toothwort
x	P-CARDIPH	<i>Cardamine diphylla</i>	Two-leaved Toothwort
x	P-CARALBU	<i>Carex albursina</i>	White Bear Sedge
x	P-CARPLAN	<i>Carex plantaginea</i>	Plantain-leaved Sedge
x	P-CARRADI	<i>Carex radiata</i>	Eastern Star Sedge
x	P-CAR_SP	<i>Carex</i> sp.	Sedge Species
x	P-CARCORD	<i>Carya cordiformis</i>	Bitternut Hickory
x	P-CAROVAT	<i>Carya ovata</i>	Shagbark Hickory
x	P-CAUGIGA	<i>Caulophyllum giganteum</i>	Giant Blue Cohosh
x	P-CAUTHAL	<i>Caulophyllum thalictroides</i>	Blue Cohosh
x	P-CHEMAJU	<i>Chelidonium majus</i>	Greater Celandine
x	P-CICINTY	<i>Cichorium intybus</i>	Chicory
x	P-CIRLUCA	<i>Circaea canadensis</i> ssp. <i>canadensis</i>	Canada Enchanter's Nightshade
x	P-CIRVULG	<i>Cirsium vulgare</i>	Bull Thistle
x	P-CLAVIRG	<i>Claytonia virginica</i>	Narrow-leaved Spring Beauty
x	P-CLIVULG	<i>Clinopodium vulgare</i>	Field Basil
x	P-CONMAJA	<i>Convallaria majalis</i>	European Lily-of-the-valley
x	P-CORALTE	<i>Cornus alternifolia</i>	Alternate-leaved Dogwood
x	P-CORFORA	<i>Cornus racemosa</i>	Gray Dogwood
x	P-CORRUGO	<i>Cornus rugosa</i>	Round-leaved Dogwood
x	P-CORSTOL	<i>Cornus sericea</i>	Red-osier Dogwood
x	P-CRA_SP	<i>Crataegus</i> sp.	Hawthorn Species
x	P-CYSBULB	<i>Cystopteris bulbifera</i>	Bulblet Fern
x	P-DACGLOM	<i>Dactylis glomerata</i>	Orchard Grass
x	P-DAUCARO	<i>Daucus carota</i>	Wild Carrot
x	P-DICCANA	<i>Dicentra canadensis</i>	Squirrel-corn
x	P-DICCUCU	<i>Dicentra cucullaria</i>	Dutchman's Breeches
x	P-DIELONI	<i>Diervilla lonicera</i>	Northern Bush-honeysuckle
x	P-DIPFUSY	<i>Dipsacus fullonum</i>	Common Teasel

Plant Species Inventoried in Winona and Vinemount Conservation Areas (cont.)

x	P-DRYCART	<i>Dryopteris carthusiana</i>	Spinulose Wood Fern
x	P-DRYGOLD	<i>Dryopteris goldiana</i>	Goldie's Wood Fern
x	P-DRYINTE	<i>Dryopteris intermedia</i>	Evergreen Wood Fern
x	P-DRYMARG	<i>Dryopteris marginalis</i>	Marginal Wood Fern
x	P-ELYREPE	<i>Elymus repens</i>	Creeping Wildrye
x	P-EPIHELL	<i>Epipactis helleborine</i>	Eastern Helleborine
x	P-ERIANNU	<i>Erigeron annuus</i>	Annual Fleabane
x	P-ERIPHIL	<i>Erigeron philadelphicus</i>	Philadelphia Fleabane
x	P-ERYAMAM	<i>Erythronium americanum</i> ssp. <i>americanum</i>	Yellow Trout-lily
x	P-EUOOBOV	<i>Euonymus obovatus</i>	Running Strawberry Bush
x	P-ASTMACR	<i>Eurybia macrophylla</i>	Large-leaved Aster
x	P-EUTGRAM	<i>Euthamia graminifolia</i>	Grass-leaved Goldenrod
x	P-FAGGRAN	<i>Fagus grandifolia</i>	American Beech
x	P-FER_SP	Fern sp.	Fern Species
x	P-FRAVEAM	<i>Fragaria vesca</i> ssp. <i>americana</i>	American Woodland Strawberry
x	P-RHAFRAN	<i>Frangula alnus</i>	Glossy Buckthorn
x	P-FRAAMER	<i>Fraxinus americana</i>	White Ash
x	P-FRAPENN	<i>Fraxinus pennsylvanica</i>	Green Ash
x	P-GALAPAR	<i>Galium aparine</i>	Cleavers
x	P-GAL_SP	Galium sp.	Bedstraw Species
x	P-GERMACU	<i>Geranium maculatum</i>	Spotted Geranium
x	P-GERROBE	<i>Geranium robertianum</i>	Herb-Robert
x	P-GEUALEP	<i>Geum aleppicum</i>	Yellow Avens
x	P-GEUCANA	<i>Geum canadense</i>	White Avens
x	P-WALFRAG	<i>Geum fragarioides</i>	Barren Strawberry
x	P-GEULACI	<i>Geum laciniatum</i>	Rough Avens
x	P-GEU_SP	Geum sp.	Avens Species
x	P-GLEHEDE	<i>Glechoma hederacea</i>	Ground Ivy
x	P-GLYSTRI	<i>Glyceria striata</i>	Fowl Mannagrass
x	P-HACVIRG	<i>Hackelia virginiana</i>	Virginia Stickseed
x	P-HAMVIRG	<i>Hamamelis virginiana</i>	American Witch-hazel
x	P-HEPACTU	<i>Hepatica acutiloba</i>	Sharp-lobed Hepatica
x	P-ANEAMER	<i>Hepatica americana</i>	Round-lobed Hepatica
x	P-HESMATR	<i>Hesperis matronalis</i>	Dame's Rocket
x	P-HIESCAU	<i>Hieracium scabrum</i>	Rough Hawkweed
x	P-HYDCANY	<i>Hydrophyllum canadense</i>	Canada Waterleaf
x	P-HYDVIRG	<i>Hydrophyllum virginianum</i>	Virginia Waterleaf
x	P-IMPCAPE	<i>Impatiens capensis</i>	Spotted Jewelweed
x	P-IMPPALL	<i>Impatiens pallida</i>	Pale Jewelweed
x	P-IRIVERS	<i>Iris versicolor</i>	Harlequin Blue Flag
x	P-JUGCINE	<i>Juglans cinerea</i>	Butternut
x	P-JUGNIGR	<i>Juglans nigra</i>	Black Walnut
x	P-LAPCANA	<i>Laportea canadensis</i>	Wood Nettle
x	P-LAPCOMM	<i>Lapsana communis</i>	Common Nipplewort
x	P-LEE_SP	Leersia sp.	Cut Grass Species
x	P-LIC_SP	Lichen sp.	Lichen Species
x	P-LIGVULG	<i>Ligustrum vulgare</i>	European Privet
x	P-LONCANA	<i>Lonicera canadensis</i>	Canada Fly Honeysuckle
x	P-LONDIOI	<i>Lonicera dioica</i>	Limber Honeysuckle
x	P-LONMAAC	<i>Lonicera maackii</i>	Amur Honeysuckle
x	P-LON_SP	Lonicera sp.	Honeysuckle Species
x	P-LONTATA	<i>Lonicera tatarica</i>	Tartarian Honeysuckle
x	P-LUNANNU	<i>Lunaria annua</i>	Annual Honesty
x	P-LYTSALI	<i>Lythrum salicaria</i>	Purple Loosestrife
x	P-MAICANA	<i>Maianthemum canadense</i>	Wild Lily-of-the-valley

Plant Species Inventoried in Winona and Vinemount Conservation Areas (cont.)

x	P-MAIRARA	<i>Maianthemum racemosum</i>	Large False Solomon's Seal
x	P-MAI_SP	<i>Maianthemum</i> sp.	False Soloman's Seal Species
x	P-MATSTPE	<i>Matteuccia struthiopteris</i> var. <i>pensylvanica</i>	Ostrich Fern
x	P-MENCANA	<i>Menispermum canadense</i>	Canada Moonseed
x	P-MITDIPH	<i>Mitella diphylla</i>	Two-leaved Mitrewort
x	P-MORALBA	<i>Morus alba</i>	White Mulberry
x	P-PREALBA	<i>Nabalus albus</i>	White Rattlesnakeroot
x	P-MOS_SP	no data2	Moss Species
x	P-ONOSENS	<i>Onoclea sensibilis</i>	Sensitive Fern
x	P-OSTVIRG	<i>Ostrya virginiana</i>	Eastern Hop-hornbeam
x	P-OXACORN	<i>Oxalis corniculata</i>	Creeping Wood-sorrel
x	P-OXASTRI	<i>Oxalis stricta</i>	Upright Yellow Wood-sorrel
x	P-PARQUIN	<i>Parthenocissus quinquefolia</i>	Virginia Creeper
x	P-PARINSE	<i>Parthenocissus vitacea</i>	Thicket Creeper
x	P-POLLAPA	<i>Persicaria lapathifolia</i>	Pale Smartweed
x	P-PHAARUN	<i>Phalaris arundinacea</i>	Reed Canary Grass
x	P-PHRAUST	<i>Phragmites australis</i>	Common Reed
x	P-PHRLEPT	<i>Phryma leptostachya</i>	Lopseed
x	P-PILPUMI	<i>Pilea pumila</i>	Dwarf Clearweed
x	P-PIL_SP	<i>Pilea</i> sp.	Clearweed Species
x	P-HIECACA	<i>Pilosella caespitosa</i>	Meadow Hawkweed
x	P-PINSTRO	<i>Pinus strobus</i>	Eastern White Pine
x	P-PLAMAJO	<i>Plantago major</i>	Common Plantain
x	P-POANEMO	<i>Poa nemoralis</i>	Woods Bluegrass
x	P-GRA_SP	<i>Poa</i> sp.	Grass Species
x	P-PODPELT	<i>Podophyllum peltatum</i>	May-apple
x	P-POLACRO	<i>Polystichum acrostichoides</i>	Christmas Fern
x	P-POPDEDE	<i>Populus deltoides</i> ssp. <i>deltoides</i>	Eastern Cottonwood
x	P-POPGRAN	<i>Populus grandidentata</i>	Large-toothed Aspen
x	P-POPTREM	<i>Populus tremuloides</i>	Trembling Aspen
x	P-DUCINDI	<i>Potentilla indica</i>	Mock-strawberry
x	P-PRUVUVU	<i>Prunella vulgaris</i> ssp. <i>vulgaris</i>	Common Self-heal
x	P-PRUAVIU	<i>Prunus avium</i>	Sweet Cherry
x	P-PRUSERO	<i>Prunus serotina</i>	Black Cherry
x	P-PRUVIVI	<i>Prunus virginiana</i>	Choke Cherry
x	P-PYRCOMM	<i>Pyrus communis</i>	Common Pear
x	P-QUEALBA	<i>Quercus alba</i>	White Oak
x	P-QUERUBR	<i>Quercus rubra</i>	Northern Red Oak
x	P-RANRECU	<i>Ranunculus recurvatus</i>	Hooked Buttercup
x	P-RHACATH	<i>Rhamnus cathartica</i>	Common Buckthorn
x	P-RHUTYPH	<i>Rhus typhina</i>	Staghorn Sumac
x	P-RIBCYNO	<i>Ribes cynosbati</i>	Prickly Gooseberry
x	P-ROSCARO	<i>Rosa carolina</i>	Carolina Rose
x	P-ROSMULT	<i>Rosa multiflora</i>	Multiflora Rose
x	P-RUBALLE	<i>Rubus allegheniensis</i>	Allegheny Blackberry
x	P-RUBIDID	<i>Rubus idaeus</i> ssp. <i>idaeus</i>	Common Red Raspberry
x	P-RUBIDME	<i>Rubus idaeus</i> ssp. <i>strigosus</i>	Wild Red Raspberry
x	P-RUBOCCI	<i>Rubus occidentalis</i>	Black Raspberry
x	P-RUBODOR	<i>Rubus odoratus</i>	Purple-flowering Raspberry
x	P-RUDHIRT	<i>Rudbeckia hirta</i>	Black-eyed Susan
x	P-RUM_SP	<i>Rumex</i> sp.	Dock Species
x	P-SAL_SP	<i>Salix</i> sp.	Willow Species
x	P-SAL_SP	<i>Salix</i> sp.	Willow Species
x	P-SAMCANA	<i>Sambucus canadensis</i>	Common Elderberry
x	P-SAMRAPU	<i>Sambucus racemosa</i> ssp. <i>pubens</i>	Red Elderberry

Plant Species Inventoried in Winona and Vinemount Conservation Areas (cont.)

x	P-SANCANA	<i>Sanguinaria canadensis</i>	Bloodroot
x	P-CORVARI	<i>Securigera varia</i>	Common Crown-vetch
x	P-SOLDULC	<i>Solanum dulcamara</i>	Bittersweet Nightshade
x	P-SOLALAL	<i>Solidago altissima</i> var. <i>altissima</i>	Eastern Tall Goldenrod
x	P-SOLCAES	<i>Solidago caesia</i>	Blue-stemmed Goldenrod
x	P-SOLCANA	<i>Solidago canadensis</i>	Canada Goldenrod
x	P-SOLFLEX	<i>Solidago flexicaulis</i>	Zigzag Goldenrod
x	P-SONOLER	<i>Sonchus oleraceus</i>	Common Sow-thistle
x	P-STATRIF	<i>Staphylea trifolia</i>	American Bladdernut
x	P-ASTCORD	<i>Symphyotrichum cordifolium</i>	Heart-leaved Aster
x	P-ASTERER	<i>Symphyotrichum ericoides</i> var. <i>ericoides</i>	White Heath Aster
x	P-ASTLALN	<i>Symphyotrichum lanceolatum</i> ssp. <i>lanceolatum</i>	Panicled Aster
x	P-ASTLATE	<i>Symphyotrichum lateriflorum</i>	Calico Aster
x	P-ASTNOVA	<i>Symphyotrichum novae-angliae</i>	New England Aster
x	P-ASTONON	<i>Symphyotrichum ontarionis</i>	Ontario Aster
x	P-ASTPIPI	<i>Symphyotrichum pilosum</i> var. <i>pilosum</i>	Old Field Aster
x	P-ASTPUPU	<i>Symphyotrichum puniceum</i> var. <i>puniceum</i>	Swamp Aster
x	P-ASTUROP	<i>Symphyotrichum urophyllum</i>	Arrow-leaved Aster
x	P-TAROFFI	<i>Taraxacum officinale</i>	Common Dandelion
x	P-THADIOI	<i>Thalictrum dioicum</i>	Early Meadow-rue
x	P-THUOCCI	<i>Thuja occidentalis</i>	Eastern White Cedar
x	P-TIACORD	<i>Tiarella cordifolia</i>	Heart-leaved Foam-flower
x	P-TILAMER	<i>Tilia americana</i>	American Basswood
x	P-TORJAPO	<i>Torilis japonica</i>	Erect Hedge-parsley
x	P-RHURADI	<i>Toxicodendron radicans</i>	Poison Ivy
x	P-RHURANE	<i>Toxicodendron radicans</i> var. <i>radicans</i>	Eastern Poison Ivy
x	P-RHURARY	<i>Toxicodendron radicans</i> var. <i>rydbergii</i>	Western Poison Ivy
x	P-TRIEREC	<i>Trillium erectum</i>	Red Trillium
x	P-TRIGRAN	<i>Trillium grandiflorum</i>	White Trillium
x	P-TUSFARF	<i>Tussilago farfara</i>	Colt's-foot
x	P-TYPANGU	<i>Typha angustifolia</i>	Narrow-leaved Cattail
x	P-ULMAMER	<i>Ulmus americana</i>	American Elm
x	P-ULMRUBR	<i>Ulmus rubra</i>	Slippery Elm
x	P-UVUGRAN	<i>Uvularia grandiflora</i>	Large-flowered Bellwort
x	P-VIBACER	<i>Viburnum acerifolium</i>	Maple-leaved Viburnum
x	P-VIBLENT	<i>Viburnum lentago</i>	Nannyberry
x	P-VIBOPUL	<i>Viburnum opulus</i>	Cranberry Viburnum
x	P-VICCRAC	<i>Vicia cracca</i>	Tufted Vetch
x	P-VINMINO	<i>Vinca minor</i>	Periwinkle
x	P-VIOCANA	<i>Viola canadensis</i>	Canada Violet
x	P-VIOPUBE	<i>Viola pubescens</i>	Yellow Violet
x	P-VIOSORO	<i>Viola sororia</i>	Woolly Blue Violet
x	P-VIO_SP	<i>Viola</i> sp.	Violet Species
x	P-VITRIPA	<i>Vitis riparia</i>	Riverbank Grape

Bird Species Inventoried in Winona and Vinemount Conservation Areas

ebird&iNat	HCA Staff	NAI	Species_Code	OFO_Scientific_Name	OFO_Common_Name
x			B-CORE	Acanthis flammea	Common Redpoll
	x		B-COHA	Accipiter cooperii	Cooper's Hawk
	x		B-SSHA	Accipiter striatus	Sharp-shinned Hawk
		x	B-SPSA	Actitis macularius	Spotted Sandpiper
x			B-NSWO	Aegolius acadicus	Northern Saw-whet Owl
	x		B-RWBL	Agelaius phoeniceus	Red-winged Blackbird
x			B-MALL	Anas platyrhynchos	Mallard
x			B-SACR	Antigone canadensis	Sandhill Crane
x			B-WPWI	Antrastomus vociferus	Eastern Whip-poor-will
		x	B-RTHU	Archilochus colubris	Ruby-throated Hummingbird
	x		B-CEDW	Bombycilla cedrorum	Cedar Waxwing
		x	B-CAGO	Branta canadensis	Canada Goose
x			B-GHOW	Bubo virginianus	Great Horned Owl
	x		B-RTHA	Buteo jamaicensis	Red-tailed Hawk
x			B-RSHA	Buteo lineatus	Red-shouldered Hawk
x			B-BWHA	Buteo platypterus	Broad-winged Hawk
	x		B-NOCA	Cardinalis cardinalis	Northern Cardinal
x			B-HETH	Catharus guttatus	Hermit Thrush
x			B-SWTH	Catharus ustulatus	Swainson's Thrush
	x		B-BRCR	Certhia americana	Brown Creeper
		x	B-CHSW	Chaetura pelagica	Chimney Swift
		x	B-KILL	Charadrius vociferus	Killdeer
x			B-NOHA	Circus hudsonius	Northern Harrier
	x		B-YBCU	Coccyzus americanus	Yellow-billed Cuckoo
	x		B-BBCU	Coccyzus erythrophthalmus	Black-billed Cuckoo
	x		B-NOFL	Colaptes auratus	Northern Flicker
		x	B-RODO	Columba livia	Rock Pigeon
	x		B-EAWP	Contopus virens	Eastern Wood-Pewee
		x	B-AMCR	Corvus brachyrhynchos	American Crow
x			B-CORA	Corvus corax	Common Raven
	x		B-BLJA	Cyanocitta cristata	Blue Jay
x			B-TUSW	Cygnus columbianus	Tundra Swan
		x	B-BOBO	Dolichonyx oryzivorus	Bobolink
	x		B-DOWO	Dryobates pubescens	Downy Woodpecker
		x	B-HAWO	Dryobates villosus	Hairy Woodpecker
	x		B-GRCA	Dumetella carolinensis	Gray Catbird
		x	B-ALFL	Empidonax alnorum	Alder Flycatcher
		x	B-LEFL	Empidonax minimus	Least Flycatcher
		x	B-WIFL	Empidonax traillii	Willow Flycatcher
		x	B-HOLA	Eremophila alpestris	Horned Lark
x			B-MERL	Falco columbarius	Merlin
x			B-PEFA	Falco peregrinus	Peregrine Falcon
		x	B-AMKE	Falco sparverius	American Kestrel
		x	B-MOWA	Geothlypis philadelphia	Mourning Warbler
		x	B-HOFI	Haemorhous mexicanus	House Finch
x			B-PUFI	Haemorhous purpureus	Purple Finch
x			B-BAEA	Haliaeetus leucocephalus	Bald Eagle
		x	B-BARS	Hirundo rustica	Barn Swallow
x			B-CATE	Hydroprogne caspia	Caspian Tern
	x		B-WOTH	Hylocichla mustelina	Wood Thrush
		x	B-OROR	Icterus spurius	Orchard Oriole
x			B-DEJU	Junco hyemalis	Dark-eyed Junco
x			B-NSHR	Lanius borealis	Northern Shrike
		x	B-HERG	Larus argentatus	Herring Gull

Bird Species Inventoried in Winona and Vinemount Conservation Areas (cont.)

		x	B-RBGU	<i>Larus delawarensis</i>	Ring-billed Gull
x			B-BEKI	<i>Megaceryle alcyon</i>	Belted Kingfisher
x			B-EASO	<i>Megascops asio</i>	Eastern Screech-Owl
	x		B-RBWO	<i>Melanerpes carolinus</i>	Red-bellied Woodpecker
	x		B-WITU	<i>Meleagris gallopavo</i>	Wild Turkey
		x	B-SWSP	<i>Melospiza georgiana</i>	Swamp Sparrow
	x		B-SOSP	<i>Melospiza melodia</i>	Song Sparrow
		x	B-NOMO	<i>Mimus polyglottos</i>	Northern Mockingbird
	x		B-BHCO	<i>Molothrus ater</i>	Brown-headed Cowbird
	x		B-GCFL	<i>Myiarchus crinitus</i>	Great Crested Flycatcher
x			B-NAWA	<i>Oreothlypis ruficapilla</i>	Nashville Warbler
x			B-OSPR	<i>Pandion haliaetus</i>	Osprey
		x	B-NOWA	<i>Parkesia noveboracensis</i>	Northern Waterthrush
		x	B-HOSP	<i>Passer domesticus</i>	House Sparrow
		x	B-SAVS	<i>Passerculus sandwichensis</i>	Savannah Sparrow
x			B-FOSP	<i>Passerella iliaca</i>	Fox Sparrow
	x		B-INBU	<i>Passerina cyanea</i>	Indigo Bunting
		x	B-RINP	<i>Phasianus colchicus</i>	Ring-necked Pheasant
		x	B-RBGR	<i>Pheucticus ludovicianus</i>	Rose-breasted Grosbeak
		x	B-SCTA	<i>Piranga olivacea</i>	Scarlet Tanager
x			B-SNBU	<i>Plectrophenax nivalis</i>	Snow Bunting
	x		B-BCCH	<i>Poecile atricapillus</i>	Black-capped Chickadee
		x	B-BGGN	<i>Poliptila caerulea</i>	Blue-gray Gnatcatcher
		x	B-PUMA	<i>Progne subis</i>	Purple Martin
	x		B-COGR	<i>Quiscalus quiscula</i>	Common Grackle
x			B-RCKI	<i>Regulus calendula</i>	Ruby-crowned Kinglet
x			B-GCKI	<i>Regulus satrapa</i>	Golden-crowned Kinglet
		x	B-BANS	<i>Riparia riparia</i>	Bank Swallow
x			B-EAPH	<i>Sayornis phoebe</i>	Eastern Phoebe
		x	B-AMWO	<i>Scolopax minor</i>	American Woodcock
		x	B-OVEN	<i>Seiurus aurocapilla</i>	Ovenbird
x			B-BTBW	<i>Setophaga caeruleascens</i>	Black-throated Blue Warbler
x			B-BBWA	<i>Setophaga castanea</i>	Bay-breasted Warbler
	x		B-HOWA	<i>Setophaga citrina</i>	Hooded Warbler
		x	B-YRWA	<i>Setophaga coronata</i>	Yellow-rumped Warbler
x			B-PAWA	<i>Setophaga palmarum</i>	Palm Warbler
	x		B-CSWA	<i>Setophaga pensylvanica</i>	Chestnut-sided Warbler
	x		B-YWAR	<i>Setophaga petechia</i>	Yellow Warbler
		x	B-AMRE	<i>Setophaga ruticilla</i>	American Redstart
		x	B-BLPW	<i>Setophaga striata</i>	Blackpoll Warbler
x			B-BTGW	<i>Setophaga virens</i>	Black-throated Green Warbler
		x	B-EABL	<i>Sialia sialis</i>	Eastern Bluebird
x			B-RBNU	<i>Sitta canadensis</i>	Red-breasted Nuthatch
	x		B-WBNU	<i>Sitta carolinensis</i>	White-breasted Nuthatch
x			B-PISI	<i>Spinus pinus</i>	Pine Siskin
	x		B-AMGO	<i>Spinus tristis</i>	American Goldfinch
		x	B-CCSP	<i>Spizella pallida</i>	Clay-colored Sparrow
		x	B-CHSP	<i>Spizella passerina</i>	Chipping Sparrow
		x	B-FISP	<i>Spizella pusilla</i>	Field Sparrow
x			B-ATSP	<i>Spizelloides arborea</i>	American Tree Sparrow
		x	B-NRWS	<i>Stelgidopteryx serripennis</i>	Northern Rough-winged Swallow
		x	B-EAME	<i>Sturnella magna</i>	Eastern Meadowlark
	x		B-EUST	<i>Sturnus vulgaris</i>	European Starling
		x	B-TRES	<i>Tachycineta bicolor</i>	Tree Swallow
	x		B-CARW	<i>Thryothorus ludovicianus</i>	Carolina Wren

Bird Species Inventoried in Winona and Vinemount Conservation Areas (cont.)

	x		B-HOWR	Troglodytes aedon	House Wren
	x		B-WIWR	Troglodytes hiemalis	Winter Wren
	x		B-AMRO	Turdus migratorius	American Robin
		x	B-EAKI	Tyrannus tyrannus	Eastern Kingbird
	x		B-YTVI	Vireo flavifrons	Yellow-throated Vireo
		x	B-WAVI	Vireo gilvus	Warbling Vireo
	x		B-REVI	Vireo olivaceus	Red-eyed Vireo
	x		B-MODO	Zenaida macroura	Mourning Dove
		x	B-WTSP	Zonotrichia albicollis	White-throated Sparrow
x			B-WCSP	Zonotrichia leucophrys	White-crowned Sparrow

Mammal Species Inventoried in Winona and Vinemount Conservation Areas

HCA staff	NAI	Species_Code	Scientific_Name_NHIC	Common_Name_NHIC
	x	M-NSTS	Blarina brevicauda	Northern Short-tailed Shrew
	x	M-VIOP	Didelphis virginiana	Virginia Opossum
	x	M-WOOD	Marmota monax	Woodchuck
	x	M-MEVO	Microtus pennsylvanicus	Meadow Vole
	x	M-MINK	Neovison vison	American Mink
x		M-WTDE	Odocoileus virginianus	White-tailed Deer
	x	M-WFMO	Peromyscus leucopus	White-footed Mouse
x		M-RACC	Procyon lotor	Northern Raccoon
x		M-GRSB	Sciurus carolinensis	Eastern Gray Squirrel Black Phase
	x	M-GRSQ	Sciurus carolinensis	Eastern Gray Squirrel
	x	M-EACO	Sylvilagus floridanus	Eastern Cottontail
x		M-EACH	Tamias striatus	Eastern Chipmunk
x		M-RESQ	Tamiasciurus hudsonicus	Red Squirrel
x		M-REFO	Vulpes vulpes	Red Fox

Butterflies and Dragonflies Surveyed in Winona and Vinemount Conservation Areas				
HCA Staff	NAI	Species_Code	NHIC_Scientific_Name	NHIC_Common_Name
	x	O-GRDA	Anax junius	Common Green Darner
	x	L-LESK	Ancyloxypha numitor	Least Skipper
	x	O-EBJE	Calopteryx maculata	Ebony Jewelwing
	x	L-SPAZ	Celastrina lucia	Northern Spring Azure
	x	L-SUAZ	Celastrina neglecta	Summer Azure
	x	L-WONY	Cercyonis pegala	Common Wood-Nymph
	x	L-CORI	Coenonympha tullia	Common Ringlet
	x	L-ORSU	Colias eurytheme	Orange Sulphur
	x	L-COSU	Colias philodice	Clouded Sulphur
	x	L-ETBL	Cupido comyntas	Eastern Tailed Blue
	x	L-MONA	Danaus plexippus	Monarch
	x	O-FABL	Enallagma civile	Familiar Bluet
	x	L-SSSK	Epargyreus clarus	Silver-spotted Skipper
	x	O-EAPO	Erythemis simplicicollis	Eastern Pondhawk
	x	L-SIBL	Glaucopsyche lygdamus	Silvery Blue
	x	O-EAFO	Ischnura verticalis	Eastern Forktail
	x	O-DTWH	Leucorrhinia intacta	Dot-tailed Whiteface
	x	O-WISK	Libellula luctuosa	Widow Skimmer
	x	O-TSSK	Libellula pulchella	Twelve-spotted Skimmer
	x	L-VICE	Limenitis archippus	Viceroy
	x	L-LWSA	Megisto cymela	Little Wood-Satyr
x		L-MOCL	Nymphalis antiopa	Mourning Cloak
	x	L-COTO	Nymphalis l-album	Compton Tortoiseshell
	x	L-TISW	Papilio glaucus	Eastern Tiger Swallowtail
	x	L-BLSW	Papilio polyxenes	Black Swallowtail
	x	L-COSW	Pholisora catullus	Common Sootywing
	x	L-PHYPAS	Phyciodes cocyta	Northern Crescent
	x	L-PECR	Phyciodes tharos	Pearl Crescent
	x	L-CAWH	Pieris rapae	Cabbage White
	x	O-COWH	Plathemis lydia	Common Whitetail
	x	L-PESK	Polites peckius	Peck's Skipper
	x	L-COMM	Polygonia comma	Eastern Comma
	x	L-QUMA	Polygonia interrogationis	Question Mark
	x	L-BAHA	Satyrium calanus	Banded Hairstreak
	x	L-GSFR	Speyeria cybele	Great Spangled Fritillary
	x	L-EUSK	Thymelicus lineola	European Skipper
	x	O-BLSA	Tramea lacerata	Black Saddlebags
	x	L-READ	Vanessa atalanta	Red Admiral
	x	L-AMLA	Vanessa virginiensis	American Lady

Amphibians and Reptiles Inventoried in Winona and Vinemount Conservation Areas

All	Species_Code	SCIENTIFIC_NAME_NHIC	COMMON_NAME_NHIC
x	H-JEFF	Ambystoma (jeffersonianum complex)	Jefferson complex (undetermined)
x	H-JESA	Ambystoma jeffersonianum	Jefferson Salamander
x	H-AMTO	Anaxyrus americanus	American Toad
x	H-SNTU	Chelydra serpentina	Snapping Turtle
x	H-MPTU	Chrysemys picta marginata	Midland Painted Turtle
x	H-TGTF	Hyla versicolor	Gray Treefrog
x	H-MISN	Lampropeltis triangulum	Eastern Milksnake
x	H-BUFR	Lithobates catesbeianus	American Bullfrog
x	H-GRFR	Lithobates clamitans	Green Frog
x	H-LEFR	Lithobates pipiens	Northern Leopard Frog
x	H-EANE	Notophthalmus viridescens viridescens	Red-spotted Newt
x	H-RBSA	Plethodon cinereus	Eastern Red-backed Salamander
x	H-SPPE	Pseudacris crucifer	Spring Peeper
x	H-MICF	Pseudacris triseriata pop. 2	Western Chorus Frog - Carolinian Population
x	H-BRSN	Storeria dekayi	DeKay's Brownsnake
x	H-RBSN	Storeria occipitomaculata	Red-bellied Snake
x	H-EAGA	Thamnophis sirtalis sirtalis	Eastern Gartersnake
x	H-SLID	Trachemys scripta elegans	Red-eared Slider
x	H-UNKNOWN	Unknown sp.	Unknown Herp Species

APPENDIX 5

References

References

Bruce Trail Conservancy. Online information from the head office located in Dundas, Ontario as posted at www.brucetrail.org

Hamilton Conservation Authority, Land Acquisition Records, *Lands in the City of Stoney Creek. Letter correspondence with Janice Elaine Lapceвич*, June 3, 1997.

Hamilton Conservation Authority Board of Directors, Board Report BD/Nov 04-2010. Llewellyn and Susan Smith – Land Donation – Stoney Creek. October 28, 2010.

Hamilton Community News, *Smith gift completes Winona link on Bruce Trail*, February 14, 2012.

Hamilton- Wentworth and Niagara, Winona Escarpment Slopes Life Science Inventory and Field Survey. D. Macdonald and P.F. Maycock, August 1975.

Ministry of Northern Development, Mines, Natural Resources and Forestry. Niagara Escarpment Parks and Open Space System Planning Manual (2021). Queen's Printer for Ontario. 2021

Silv-Econ Ltd., David Puttock R.P.F. Managed Forest Plan 2018-2037. Hamilton Conservation Authority. July 2017



**Hamilton
Conservation
Authority**

A Healthy Watershed for Everyone

Hamilton Conservation Authority
838 Mineral Springs Road, P.O. Box 81067
Ancaster, Ontario, L9G 4X1
905-525-2181 www.conservationhamilton.ca



Dofasco 2000 Trail Management Plan

Draft - March 2024



Hamilton
Conservation
Authority

A Healthy Watershed for Everyone

693



Prepared by: Hamilton Region Conservation Authority (HCA)

Photo Credits: HCA Staff unless otherwise specified.



TABLE OF CONTENTS

1.0	APPROVAL STATEMENT	1
2.0	INTRODUCTION	2
2.1	Area Summary	2
2.2	Key Items	2
2.3	Goals and Objectives	2
3.0	BACKGROUND	6
3.1	Study Area	6
3.2	Property History	6
3.3	Planning and Development Controls	9
3.4	Management Plan Zones	9
4.0	NATURAL AREA INVENTORY	11
4.1	Natural Features	11
4.2	Aquatic Inventory	12
5.0	CONSERVATION AREA MANAGEMENT	15
5.1	Trail Infrastructure	15
5.2	Connections to Hamilton Conservation Areas	22
6.0	MANAGEMENT PRACTICES	24
6.1	Natural Heritage Conservation	24
6.2	Water Management.....	24
6.3	Conservation Area Experience	25
6.4	Education and Environmental Awareness	26
6.5	Management Guidelines.....	27
6.6	Maintenance Guidelines	28
7.0	SUMMARY	32
7.1	Implementation Priorities	32
8.0	APPENDIX CONTENTS	34
	Appendix 1 – Mapping	35
	Appendix 2 – Capital Development Priorities	38
	Appendix 3 – Trail Counter Data	40
	Appendix 4 – References.....	42

FIGURES

Figure 1. Study Area 7
Figure 2. Context Map 10
Figure 3. Trail Counters Summary Table 16
Figure 4. Surrounding Trails and Natural Areas 23

TABLES

Table 1. NRSI Sampling 13
Table 2. Fish Species Stoney Creek, Captured 13
Table 3. Fish Species Stoney Creek, Third Road 14
Table 4. Fish Found in Vinemount Swamp 14

1.0 APPROVAL STATEMENT

We are pleased to approve the Dofasco 2000 Trail Management Plan as the official policy document for the Hamilton Region Conservation Authority (HCA) working in cooperation with the City of Hamilton (City).

This Management plan supports HCA's current Strategic Plan and reflects our Vision of a healthy watershed for everyone and Mission to lead in the conservation of our watershed and connect people to nature.

Moving forward over the next ten years this plan will provide guidance for HCA management of the Dofasco 2000 Trail on behalf of the City in support of these goals.

Lisa Burnside
Chief Administrative Officer
Hamilton Conservation Authority

Date

Brad Clark
Chair, Board of Directors
Hamilton Conservation Authority

Date

2.0 INTRODUCTION

2.1 Area Summary

Originally called the Powerline Road Pathway, the Dofasco 2000 Trail (Dofasco Trail) is an 11.5-kilometre multi-use recreational trail located on top of the Niagara Escarpment in Stoney Creek, City of Hamilton. The trail was built over twenty years ago with the support of the Hamilton Conservation Foundation, Dofasco Inc., the Millennium Bureau of Canada and the City of Hamilton.

The main trail-head access points and parking lots are located at Devil's Punchbowl Conservation Area and the newly opened Saltfleet Conservation Area. The trail connects these conservation areas, continues east on an unopened road allowance through the rural countryside and the Vinemount South Swamp, and ends at Eleventh Road East. A small portion of the trail is on-road between Tapleystown Road and Fifth Road East, west of the Vinemount South Swamp.

In 2000 the HCA Board of Directors approved The Powerline Road Trail Master Development Plan. This document updates and replaces that plan.

2.2 Key Items

HCA staff focused on four key items of the off-road trail in preparing this Management Plan:

1. Condition of the trail infrastructure.
2. Terrestrial and aquatic ecological review of natural areas adjacent to the trail.
3. Potential linkages to Hamilton Conservation Areas for trail users.
4. Potential linkages to other recreational trails, natural areas, and features.

2.3 Goals and Objectives

This plan provides current information on the off-road trail portion managed by HCA, and provides guidance for trail management and operation for the next ten years.

HCA Strategic Plan

This Management Plan supports this Vision for the land acquisition, as well as the following long-term goals as outlined in HCA's current strategic plan:

Vision

- A healthy watershed for everyone.

Mission

- To lead in the conservation of our watershed and connect people to nature.

Commitment and Corporate Values

- Provide excellent customer service and a solution-oriented approach.

- Be accountable, transparent, and responsible in the use of resources.
- Embrace new technologies to help develop new ways of doing business and foster innovation.
- Promote teamwork internally and externally to achieve common goals, support existing relationships and build new partnerships.
- Maintain trust, act with integrity, and treat others with respect.
- Value knowledge to continually learn and improve, in an effort to achieve best solutions.

Organizational Excellence

- Ensure corporate and financial viability and the HCA’s relevance in the community.
- Identify opportunities to engage the community, adjacent landowners and Indigenous Peoples.

Water Management

- Protect the watershed for people, property, flora and fauna, and natural resources through flood and erosion control, water quality programs, low flow augmentation and adaptation strategies to adapt to changing climatic conditions.

Natural Heritage Conservation

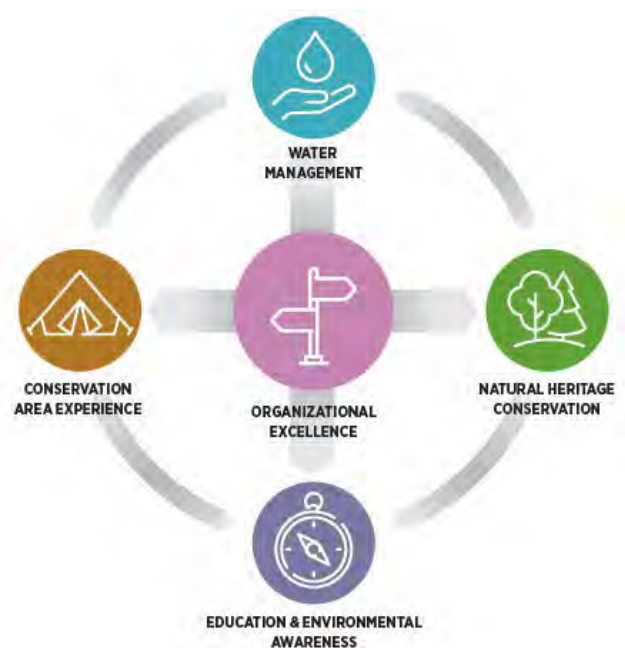
- Conservation, restoration and enhancement of watershed natural areas and ecology.
- Continue on-going ecological restoration projects and monitoring programs.
- Identify invasive species strategies and natural heritage plans in the Master plan.

Conservation Area Experience

- Provide high quality, diverse conservation areas that promote outdoor recreation, health, and well-being and strengthen public awareness of the importance of being in or near our conservation areas.
- Update and develop Master and Management plans, and implement priorities to further enhance conservation areas for current and future generations.

Education and Environmental Awareness

- Provide outdoor learning experiences for students, teachers and the community, increasing knowledge and awareness of the value of our environment and heritage.



Land Acknowledgement

The HCA joins in stewardship of lands and waters with Indigenous Peoples who have cared for them since time before memory. We acknowledge that the land on which we gather, and the HCA watershed, is part of the Treaty Lands and Territory of the Mississaugas of the Credit First Nation and traditional territory of the Haudenosaunee.

As an organization, we are committed to learning about the shared history and experiences of Indigenous Peoples in Canada and creating relationships based on respect, trust and friendship. In our shared gratitude for every aspect of the natural world, may we create a lasting legacy now and for future generations.

HCA Climate Change Strategy

The goal of HCA's Climate Change Strategy is to work towards achieving net zero status across HCA's operations through the reduction of greenhouse gases (GHG's), while also working to increase our overall adaptive capacity to changing climatic conditions.

Key Areas of Focus

Environment and Natural Heritage

- Water Management
 - Reduce water runoff, contamination, soil erosion, and other impacts of climate change on water systems
 - Reduce flooding and its impacts on lands, communities, and infrastructure
- Wetland Management
 - Identify threats to wetlands and make it easier for ecosystems to adapt to climate change
- Carbon Sequestration
 - Increase natural carbon stores which help remove excess CO₂ from the atmosphere
- Invasive Species
 - Research and monitor invasive species
 - Implement best practices in preventing the spread of invasive species
 - Communicate trends and impacts of invasive species locally
- Protection of Wildlife
 - Mitigate threats to biodiversity
- Monitoring Programs
 - Expand long-term monitoring programs
 - Maintain HCA's planning program as it relates to natural hazards and climate change implications

Experience, Education and Awareness

- Education and Awareness

- Increase awareness of individual roles in addressing climate change
- Protect staff and visitor safety

Partnerships

- Strengthen community approach and build systems for collaboration
- Learn from the work of others
- Collaboratively address threats and identify opportunities for climate adaptation and GHG reductions
- Strengthen relationships with Indigenous communities



3.0 BACKGROUND

3.1 Study Area

The Dofasco Trail is located along the municipal opened and un-opened road allowance between Devil's Punchbowl Conservation Area (DPCA) and Eleventh Road East in Stoney Creek. The trail is part of the City of Hamilton recreational trail system and offers connection between the City of Hamilton and adjacent municipalities in Niagara Region. See Figure 1. Study Area and the appended maps for more information.

3.2 Property History

The Dofasco Trail was initially identified as the Powerline Road Pathway in the City of Stoney Creek Multi-use Pathway, Pedestrian and Cycling Route Master Plan (1995). From this plan, HCA and City of Stoney Creek staff worked together on The Powerline Road Trail Master Development Plan, to provide more detailed planning information for trail construction. In 1999, the City of Stoney Creek council endorsed entering into a partnership agreement with HCA to develop and maintain the Powerline Road Trail as a new regional trail, and endorsed HCA's applications for funding of the trail construction. The Master Development Plan was approved by the HCA Board of Directors in July 2000, and became the official guiding document for the trail's construction, as well as the maintenance and operation of the trail.

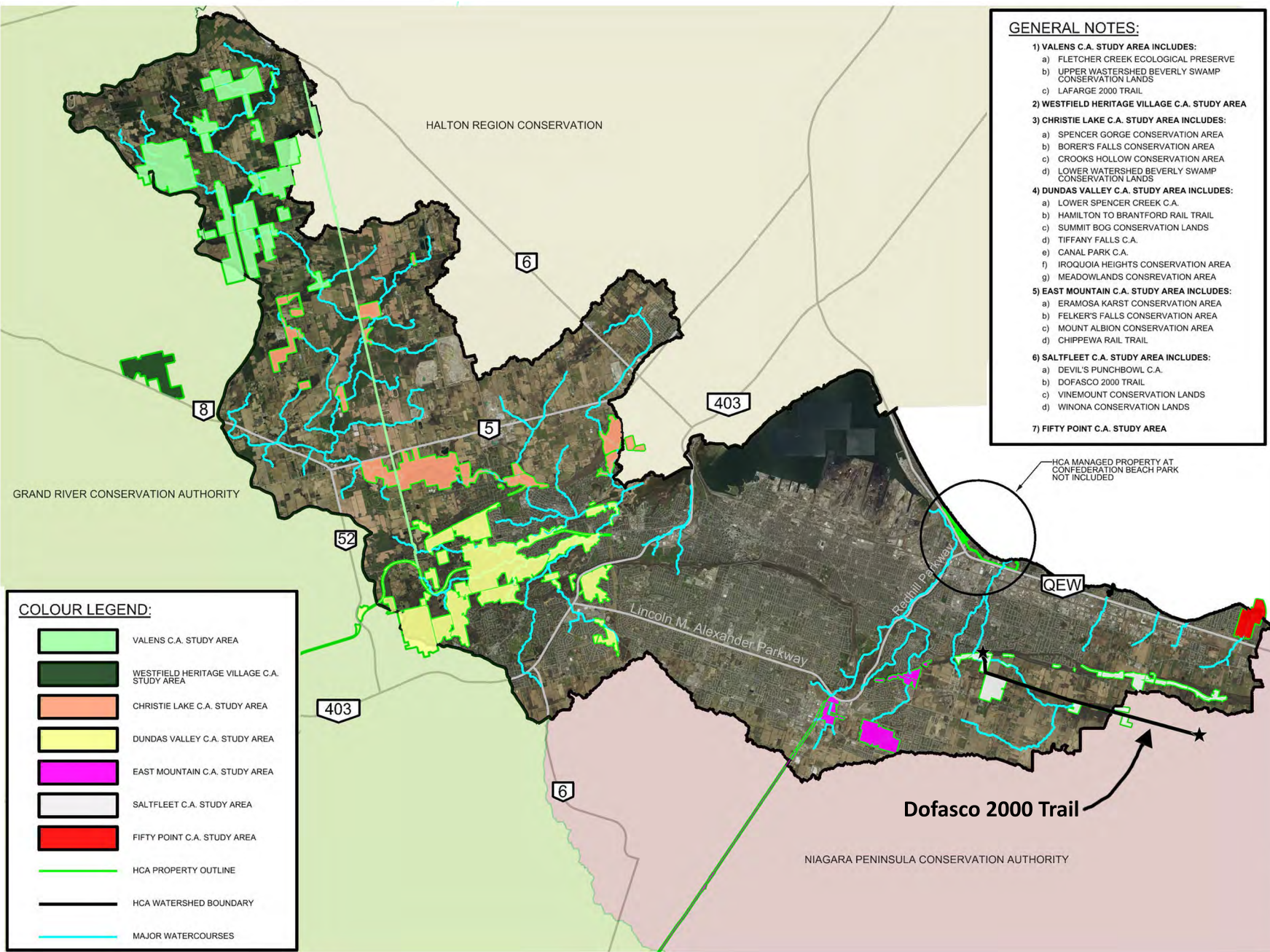
The trail was envisioned to be an important east-west link for pedestrians and bicyclists between Devil's Punchbowl Conservation Area and 87 Acres Park at Tenth Road East, with potential linkages throughout the municipality and into Niagara Region. It was anticipated that given the trail location, visitors would drive to use the trail, with trailhead parking and signage at the conservation area and 87 Acres Park. Additional trail amenities were not expected to be necessary, and interpretive information signs for the natural areas were noted as a future possibility. Trail amenities and signs are noted in Section 5.0.



In 1999, HCA's application for funding through the Canadian Millennium Partnership Program was approved with the stipulation that other funding partners contribute two thirds of the funding for this trail construction project.

In February of 2000, area residents adjacent to Powerline Road were circulated notices of the proposed trail project and invited to a public open house held March 21, 2000. It is on record that about 13 people attended this meeting, with most enquiring about the trail location and appearance. A few people identified concerns related to the properties, but overall there was a positive response to the trail.

FIGURE 1. HCA 10-YEAR MASTER PLAN STUDY AREA



- GENERAL NOTES:**
- 1) VALENS C.A. STUDY AREA INCLUDES:
 - a) FLETCHER CREEK ECOLOGICAL PRESERVE
 - b) UPPER WATERSHED BEVERLY SWAMP CONSERVATION LANDS
 - c) LAFARGE 2000 TRAIL
 - 2) WESTFIELD HERITAGE VILLAGE C.A. STUDY AREA
 - 3) CHRISTIE LAKE C.A. STUDY AREA INCLUDES:
 - a) SPENCER GORGE CONSERVATION AREA
 - b) BORER'S FALLS CONSERVATION AREA
 - c) CROOKS HOLLOW CONSERVATION AREA
 - d) LOWER WATERSHED BEVERLY SWAMP CONSERVATION LANDS
 - 4) DUNDAS VALLEY C.A. STUDY AREA INCLUDES:
 - a) LOWER SPENCER CREEK C.A.
 - b) HAMILTON TO BRANTFORD RAIL TRAIL
 - c) SUMMIT BOG CONSERVATION LANDS
 - d) TIFFANY FALLS C.A.
 - e) CANAL PARK C.A.
 - f) IROQUOIA HEIGHTS CONSERVATION AREA
 - g) MEADOWLANDS CONSERVATION AREA
 - 5) EAST MOUNTAIN C.A. STUDY AREA INCLUDES:
 - a) ERAMOSIA KARST CONSERVATION AREA
 - b) FELKER'S FALLS CONSERVATION AREA
 - c) MOUNT ALBION CONSERVATION AREA
 - d) CHIPPEWA RAIL TRAIL
 - 6) SALT FLEET C.A. STUDY AREA INCLUDES:
 - a) DEVIL'S PUNCHBOWL C.A.
 - b) DOFASCO 2000 TRAIL
 - c) VINEMOUNT CONSERVATION LANDS
 - d) WINONA CONSERVATION LANDS
 - 7) FIFTY POINT C.A. STUDY AREA

COLOUR LEGEND:

- VALENS C.A. STUDY AREA
- WESTFIELD HERITAGE VILLAGE C.A. STUDY AREA
- CHRISTIE LAKE C.A. STUDY AREA
- DUNDAS VALLEY C.A. STUDY AREA
- EAST MOUNTAIN C.A. STUDY AREA
- SALT FLEET C.A. STUDY AREA
- FIFTY POINT C.A. STUDY AREA
- HCA PROPERTY OUTLINE
- HCA WATERSHED BOUNDARY
- MAJOR WATERCOURSES



DATE: 2023/01/27

MASTER PLAN STUDY AREA MAP



Trail construction followed thereafter and the trail officially opened October 14, 2001. The trail is owned by the City and operated as a joint venture between the City and HCA. A partnership agreement between the City (formerly the Town of Stoney Creek) and HCA from 1999 is still in effect; there is a fifty-year term for this agreement with the option for renewal prior to expiry. This agreement sets out the directive for HCA to operate and maintain the unopened road allowance and abutting lands (if required) in accordance with HCA policies and standards as applicable to other HCA lands. And further that HCA secure all funding for the development, operation, and maintenance of the unopened road allowance. The portion of the trail located on public roads is under the operation of the municipality.



The off-road portions of the trail on the unopened road allowances permit users to experience the rural countryside, and three significant natural areas: the newly constructed wetlands at Saltfleet Conservation Area; Vinemount South Swamp; and Saltfleet Northeast Woods. Vinemount South Swamp is the headwater area for a branch of Stoney Creek, which flows west and is within the HCA watershed, and Forty Mile Creek which flows east and is within the Niagara Peninsula Conservation Authority (NPCA) watershed. Forty Mile Creek is also a municipal drain. Elevated boardwalks occur for 1.7 kilometers through the Vinemount South Swamp. The original boardwalks built in 2000 have been recently replaced by HCA with donor support from Dofasco Inc. and the Hamilton Conservation Foundation.

Trail users experience a variety of rural land uses including agricultural, vineyard, orchard, residential, small business, and industrial operations. Within the middle of Vinemount South Swamp there is municipal land that is the site of an old land fill operation, with some encroachment visible into the unopened road allowance. At Tenth Road East an open pit quarry is in operation, Vinemount Quarries also has access to their test wells on the north side of the trail in this area. Canadian Pacific Railways has a main rail line that crosses Tenth Road East, requiring trail users to walk along the roadway to cross the rail line. At this location there is also a small on-road parking area with interpretive sign for trail users. In the previous Master Plan, it was intended that this pull-off area would connect to more parking and trail-head amenities to be provided at 87 Acres Park.

In 2022 HCA acquired the 20.3 ha (50 acre) Punchbowl Market property at 136 Ridge Road to expand the Devil's Punchbowl Conservation Area. More information on this can be found in the 2022 Devil's Punchbowl Conservation Area Master Plan. The additional land will provide space for visitor amenities, and a new wetland designed to help prevent flooding and erosion in lower Stoney Creek. Approximately 795m of the Dofasco Trail is located within the wetland study area. The trail route will be accommodated in the wetland design and the connection to the conservation area and trail-head parking area will be maintained.

3.3 Planning and Development Controls

The trail is located in Ward 9 – Stoney Creek and subject to planning and development controls of the City of Hamilton.

The trail is also subject to additional planning and development controls. The entire trail is within the Greenbelt Plan – Protected Countryside. East of First Road East the trail abuts the south boundary of the Niagara Escarpment Plan Area. West of First Road East the trail enters Devil’s Punchbowl Conservation Area and is within the Niagara Escarpment Parks and Open Space System (NEPOSS). East of Eighth Road East the trail is in the Niagara Peninsula Conservation Authority (NPCA) watershed area.

The policies of the Niagara Escarpment Plan and guidelines of the NEPOSS 2021 planning manual have been observed in the preparation of this Management Plan.

HCA recognizes that certain public infrastructure such as utility corridors, trails or transportation links may be required to cross conservation area lands. HCA policy for planning review and regulation of these features adheres to the Conservation Authority Act, R.S.O 1990 c. 27.



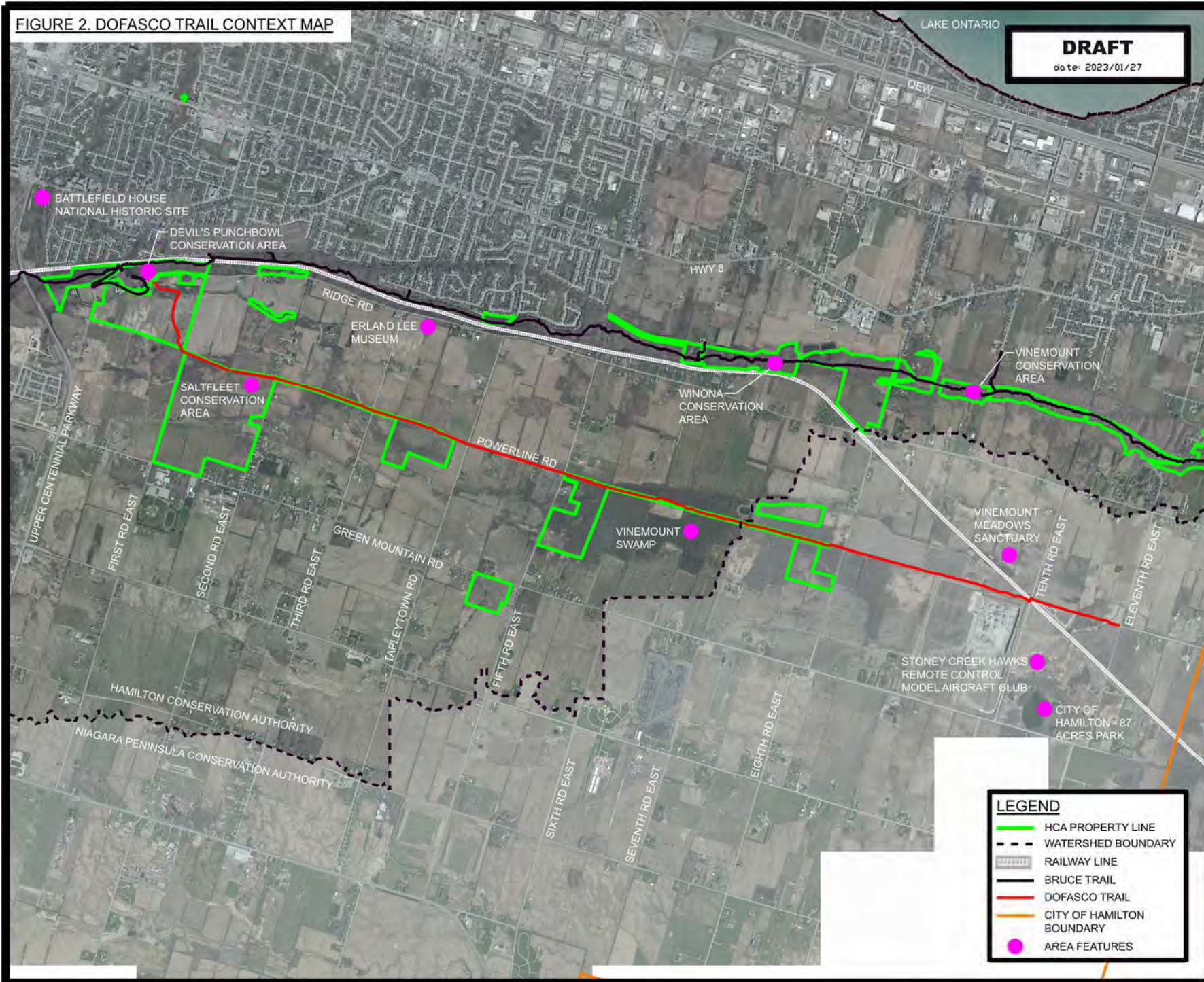
The City of Hamilton Planning and Development departments, as well as representatives from the Niagara Escarpment Commission; Ministry of Northern Development, Mines, Natural Resources and Forestry; and the NPCA have been consulted in the preparation of this Management Plan.

3.4 Management Plan Zones

Figure 2. shows the Dofasco Trail in relation to lands owned and managed by HCA. The unopened road allowance portion of the trail is the focus of this Management plan. See appended maps for more information.

The current NEPOSS Planning Manual identifies an Access Zone that would be applicable to the Dofasco Trail. Access Zones serve as staging areas to support the use of and access to adjacent land uses and zones. Minimal infrastructure is permitted such as trailhead parking, signage, and visitor amenities.

FIGURE 2. DOFASCO TRAIL CONTEXT MAP



DRAFT
date: 2023/01/27

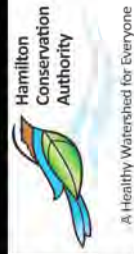


DATE: 2023/01/27

CONTEXT MAP
DOFASCO 2000 TRAIL MANAGEMENT PLAN

LEGEND

- HCA PROPERTY LINE
- WATERSHED BOUNDARY
- RAILWAY LINE
- BRUCE TRAIL
- DOFASCO TRAIL
- CITY OF HAMILTON BOUNDARY
- AREA FEATURES



A Healthy Watershed for Everyone

4.0 NATURAL AREA INVENTORY

4.1 Natural Features

For the length of the trail, the topography is generally flat with slight undulations accompanying the creeks and drainage tributaries of this tableland on top of the Niagara Escarpment. Within the broader study area, the dominant feature is the Niagara Escarpment which is located approximately 750 to 800m north of the trail. The Escarpment marks the boundary between the resistant dolostone bedrock to the south and the more easily eroded shales which occur at the base of the Escarpment and underlie the lake plain north to Lake Ontario. The elevation drops over 100m between the crest of the Escarpment and the shores of Lake Ontario.

Land uses in this area of Stoney Creek include rural residential, rural business and industrial, farming and natural areas. The off-road trail gives the public the opportunity to enjoy locally unique wetlands, swamp and woods. Along most sections of the trail is hedgerow type vegetation on either side. Also located along the trail are the Tapleystown Woods and Vinemount Meadows Sanctuary, home to a wide variety of wildlife and habitat for several species of migrating birds. Some open sections along the trail offer vistas over farm fields.



Elevated boardwalks on the trail allow visitors to cross through the Vinemount South Swamp, a provincially significant wetland and environmentally sensitive area. The boardwalks offer the public views of wetland wildlife, particularly waterfowl. This large wetland is immediately south of the Vinemount Moraine, which lies along the brow of the Niagara Escarpment. The secondary Eramosa Escarpment is less than a kilometer south. The swamp forest is the biggest natural forest area south of the Escarpment in Hamilton. It is home to several endangered and important species including the Northern Harrier, the Sedge Wren and Edward's Hairstreak Butterfly. The wetland straddles HCA's watershed boundary, and the sub-watersheds of Stoney Creek and Forty Mile Creek. From Eighth Road East the trail extends into the Niagara Peninsula Conservation Authority (NPCA) watershed.

East of the Vinemount South Swamp, the trail continues through the Saltfleet Northeast Woods. Approximately 55 ha (136 acres) in size, this group of small woodlots and marshy fields is separated from the swamp by open farm fields.



The woods provide a home to 50 species of breeding birds, nine of which are uncommon in the Hamilton area, including a breeding ground for the Sedge Wren, an elusive wren species. The CPR rail line runs southeast along the southern boundary of this area.

The Dofasco Trail travels through a variety of habitats along its length. This variety of habitat leads to a variety of bird and plant species using this trail. Breeding bird surveys were conducted on the Dofasco 2000 Trail in the spring of 2021 and 2022 and identified 34 species of birds including the Bobolink (*Dolichonyx oryzivorus*), Eastern Wood-pewee (*Contopus virens*), and Wood Thrush (*Hylocichla mustelina*) which are at risk provincially and federally. Other notable species include the Brown Creeper (*Certhia americana*), Brown Thrasher (*Toxostoma rufum*), Hairy Woodpecker (*Dryobates villosus*), Mourning Warbler (*Geothlypis philadelphia*), and Red-bellied Woodpecker (*Melanerpes carolinus*) which are considered uncommon in the City of Hamilton. According to iNaturalist, several species have been seen utilizing the area during the winter months including the Northern Harrier (*Circus hudsonius*), Northern Shrike (*Lanius borealis*), Short-eared Owl (*Asio flammeus*) (at risk provincially and federally), and White-Crowned Sparrow (*Zonotrichia leucophrys*). Snapping turtles have also been noted by staff approaching the trail for nesting in the Vinemount swamp section of the Dofasco trail.



Red-bellied Woodpecker

Plant surveys were conducted throughout the spring, summer and fall of 2022. A total of 122 plants were identified along the trail, of these 71 (58%) are native, 39 (32%) non-native with 12 identified to family only. Black Ash was recorded along the trail and has recently been designated Endangered in Ontario. Although protections have been suspended for this species from the Endangered Species Act, as an environmental agency HCA should be cautious in the removal of this species. Butternut was also found growing along the trail and is also a provincially endangered tree species. Health assessments are required before Butternuts can be removed. Two locally uncommon plant species were also found, Gray's Sedge and Purple Avens. Unfortunately, there were also a number of invasive plant species found along the Dofasco trail. Woody invasive included Common and Glossy Buckthorn which are prevalent along the trail sides along with lesser numbers of Autumn Olive and Multiflora rose. While herbaceous invasives included Garlic Mustard in low numbers, Dog-strangling vine along the trail in the Tapleystown woods and a small stand of Phragmites near the Tenth Concession.

4.2 Aquatic Inventory

The natural drainage patterns of the agricultural lands in the study area have been altered. Creeks have been channelized within a system of recti-linear drainage ditches. The wetlands similarly have these ditches running through them.

There are three main channel crossings of Stoney Creek and two of Forty Mile Creek. The trail additionally has tributary culvert crossings of Battlefield Creek in Saltfleet CA. There are also ditch crossings associated with the road crossings, and tributary culvert crossings on Powerline Rd.

The Battlefield Creek tributary crossings are in the area of the trail running adjacent to the Saltfleet Conservation Area. They drain a small private pond/wet area into the natural wetland area in SCA. There are 3 culverts present that provide this passage and this crossing is direct fish habitat. The flow is intermittent in nature and would be considered a warmwater environment. See Table 1 for the NRSI sampling that was completed as part of the Saltfleet BC-1 wetland design.

Table 1. NRSI Sampling Conducted for Saltfleet Wetland Design

Common Name	Scientific Name
Pumpkinseed	<i>Lepomis gibbosus</i>

The first Stoney Creek crossing on the trail is a bridge in Devil's Punchbowl Conservation Area.

HCA has a long-term Aquatic monitoring station located in Stoney Creek in the Devil's Punchbowl Conservation Area with records dating back to 2000. Stoney Creek in this area is intermittent in nature and the soils are shallow. The portion directly upstream of the Punchbowl waterfall flows directly on bedrock. The harsh conditions in this reach of Stoney Creek are further represented by the fish species captured, as noted in Table 2. Most sampling years the creek is so dry that no fish are present, and when they are captured only two species have been found. They are tolerant to intermediately tolerant species and indicate a coolwater thermal regime.

Table 2. Fish Species Stoney Creek Captured Devils Punchbowl/Dofasco Trail

Common Name	Scientific Name
Brook Stickleback	<i>Culaea inconstans</i>
Central Mudminnow	<i>Umbra lima</i>

The second Stoney Creek crossing along the trail is a bridge approximately 90m west of Third Road East. This reach of Stoney Creek is intermittent in nature and flows diagonally under the trail. The fish species present as noted in Table 3. indicate it is a coolwater environment but also reflect the intermittent nature of the swamp as the species represent tolerant to intermediately tolerant species.



Central Mudminnow

Table 3. Fish Species Stoney Creek Third Road West

Common Name	Scientific Name
Brook Stickleback	<i>Culaea inconstans</i>
Fathead Minnow	<i>Pimephales promelas</i>
Central Mudminnow	<i>Umbra lima</i>
Creek Chub	<i>Semotilus atromaculatus</i>
Northern Redbelly Dace	<i>Chrosomus eos</i>

The third creek crossing on the trail is a bridge approximately 250m east of Fifth Road East located in the Vinemount Swamp. Approximately 150m further east, a tributary of Stoney Creek crosses the trail at the start of a boardwalk section. The Vinemount Swamp represents the poorly drained lowlands between the two moraine features. Its drainage is enhanced by the channels dug through it which represent the watercourses in this area. This watercourse flows west out of the swamp, outletting into the main channel of Stoney Creek just east of Tapleytown Road. The fish species present as noted in Table 4 indicate it is a coolwater environment but also reflect the intermittent nature of the swamp as the species represent tolerance to intermediately tolerant species. The large sections of boardwalk through this swamp represent the best way for the trail to exist in the area and limit its impact on the aquatic ecology.

Table 4. Fish found in Vinemount Swamp Portion of the Dofasco Trail

Common Name	Scientific Name
Brook Stickleback	<i>Culaea inconstans</i>
Central Mudminnow	<i>Umbra lima</i>

The first Forty Mile Creek trail crossing is a bridge approximately 450m west of Tenth Road East. The second trail crossing is approximately 100m west of Eleventh Road East. Forty Mile Creek is located in the NPCA watershed.



5.0 CONSERVATION AREA MANAGEMENT

5.1 Trail Infrastructure

The following trail infrastructure review was conducted by HCA staff in the summer of 2022. See Appendix 2 for a summary of the recommended trail infrastructure capital projects noted in this review.

In general, the entire trail is in good condition. Lesser-used portions of the trail have some vegetation encroachment onto the trail, but overall the trail surface is in good condition. There are no benches along the trail, although a few large rocks could serve as rest areas for trail users. Accommodating accessible rest areas at various points along the trail is recommended and installation of site furnishings at rest areas could be potential donor projects (memorial benches, bike racks, etc.). Trail gates and barriers are in place at or near road crossings to block motorized vehicles from entering the trail. All of the wood trail signage is showing wear and replacement is recommended. Municipal road crossings could also be improved with crosswalks for pedestrian safety.



.1 Trail Counters

HCA installed four trail counters in May 2022 (see Appendix 3 and Figure 3. Trail Counter Summary for more information) to gather visitor data for this plan. The trail experiences consistent community use during the week, with spikes in visitation on weekends from outside visitors. The trail counter nearest to the Devil's Punchbowl CA was busiest. This location was also very popular during the fall colour season. As Hamilton's population grows, it is anticipated trail user numbers to grow, with similar trends in visitation. Trail durability and maintenance will be important to sustain the recreational trail use year-round.

Figure 3. Trail Counter Summary

Dofasco Trail Counters Summary				
	Trail Counter - Dofasco Trail at Ridge Road	Trail Counter - Dofasco Trail at First Road East	Trail Counter - Dofasco Trail at Fifth Road East	Trail Counter - Dofasco Trail at Tenth Road East
Total Monthly Counts				
May*	1819	1860	1222	1976
June	528	626	976	1525
July	1434	1474	1009	1236
August	783	374	752	1027
September	854	1138	683	890
October	2539	N/A	1106	1021
Total	7957	5472	5748	7675
Daily Averages - Days of the Week				
Monday	45	31.6	28.1	39.3
Tuesday	18	18.5	22.4	39.2
Wednesday	20.6	21.1	20.9	28.9
Thursday	16.5	25.4	21.6	35.5
Friday	27.8	23.4	24	29
Saturday	78	51.3	48	55.2
Sunday	81.5	53.1	45.8	45.3
*Based on average daily traffic				

.2 Ridge Road to First Road East

This portion of the trail is currently under review with HCA’s proposed wetland development for the Devil’s Punchbowl Conservation Area (DPCA). The trail and associated infrastructure may be recommended for relocation within the new wetland. As the wetland project proceeds through approvals, this Management Plan may be amended with the new wetland trail information. The following observations of current conditions and trail use are provided as baseline information for the wetland study area.



The trail-head for the west end of the trail is located at the DPCA visitor parking lot on Ridge Road. Visitors may access the Dofasco Trail as well as the Bruce Trail from this location

The Ridge Road trail entrance does not have the trail gates and barriers found at most other road crossings for the trail. Instead, there are large rocks spaced along the side of the road to restrict vehicle parking and access onto the trail.

Where the trail crosses Stoney Creek there is a clear-span steel bridge in good condition.

The trail surface for most of this section is mown grass, with a stone chip path varying in width down the center making it suitable for cyclists. At First Road East, there is a typical trail gate/barrier allowing cyclists and pedestrians to pass through while restricting vehicles. However, it was observed that unauthorized motorized access (ATV's) was occurring at this location on the farm lane running due west to Ridge Road. HCA staff have had to place temporary barricades and sign this lane as off-limits to trail users. Unauthorized access such as this will need to be addressed in the wetland design project proposed for the DPCA SC-5 property.

.3 First Road East to Second Road East

The trail section between First and Second Road East is very flat and follows the unopened road allowance. Saltfleet Conservation Area (Saltfleet) is adjacent to this trail section on the south side.

The surface is stone chip and the entire stretch of trail is enclosed by well-pruned vegetation. The entrances at First and Second Road East have standard gate arrangements, however the entrance at Second Road is missing one post from the typical configuration. A large rock is in its place. The sightlines at Second Road East need improvement, pedestrians and cyclists must get very close to the road edge in order to see oncoming vehicles. There is a culvert under the trail along this stretch that is in poor condition and should be replaced.

At the time that this inventory was completed, the Saltfleet wetlands were under construction. In September 2022 Saltfleet re-opened to the public, with trail access from the Dofasco Trail connecting to the Saltfleet parking lot. Trail users are just starting to discover this trail connection and parking area for the Dofasco Trail.



.4 Second Road East to Third Road East

The standard trail gates on the east side of Second Road East are set back further than on the west side. This allows farmers enough room to use the start of the trail as an access point to fields on either side of the trail. Further east, access points from these fields through the trees were visible on both sides of the trail. The openings could allow ATV access to the trails. The trail surface through this section is grass, compacted earth or stone chip. Near Third Road East there is a clear span bridge with wood decking crossing Stoney Creek. The bridge looks to be in good condition, but due to seasonal flooding, the trail design on the west side of the bridge should be reviewed. The gate at Third Road East is in the typical configuration allowing for bicycle and pedestrian access.



.5 Third Road East to Tapleystown Road

The gate on the east side of Third Road East is laid out in the standard configuration. There is a concrete barricade blocking vehicle access on the south side of the gate. The trail passes through woods north and south of the trail, the forest cover offers shade and natural habitat. HCA owns the forested property to the south.



The trail gate on the west side of Tapleystown Road is set back about 245 meters from the road. This setback allows adjacent land owners to access their property from the unopened road allowance. However, no access onto adjacent lands from the trail was observed, and dumping and vandalism were occurring on this part of the trail. This activity could be curtailed if new trail gates and barriers were permitted to be installed closer to Tapleystown Road. If new gates are installed closer to Tapleystown Road, they will be a style that facilitates accessibility for all trail users. Further review of this area with the City is recommended.

.6 Tapleytown Road to Fifth Road East

This is the only on-road section of the Dofasco Trail. Trail users can walk along Powerline Road from Tapleytown Road to Fifth Road East, a distance of about 875 meters. The road surface is asphalt and there is no sidewalk or gravel shoulder, nor signs indicating this is a portion of the trail. When this road requires replacement, it would be desirable to accommodate the trail in the road design. It is common for visitors to park their vehicles on Powerline Road and access the trail at Fifth Road East leading into the Vinemount South Swamp.



.7 Fifth Road East to Eighth Road East

Sixth and Seventh Road East do not extend through this area, so the trail from Fifth to Eighth Road East doesn't have any road crossings. The east side of Fifth Road East has trail gates allowing pedestrian and cyclist access. Heading east, the trail has a stone chip surface for about 400 meters to reach the boardwalk at the Vinemount South Swamp. There is also a clear span bridge with wood decking crossing a watercourse near the center of this segment. This bridge appears to be in good condition. The boardwalk is almost two kilometers in length, with a 380 meter stone chip trail section mid-way to Eighth Road East. At the beginning of each boardwalk section, concrete blocks are in place to prevent motor vehicle access. These were originally installed in 2010 and should be reviewed for safety and accessibility, as well as the grade of the trail up to the boardwalk. The boardwalk was recently replaced by HCA and is in very good condition. At the time of this inventory, there was one remaining boardwalk section to be replaced (west end of east boardwalk); this was completed in the winter of 2023. At Eighth Road East, the boardwalk starts about 140 meters in from the road. Approaching the boardwalk, the trail has a stone chip surface. The gate on the west side of Eighth Road East is in the standard arrangement. Parking along the shoulder of Eighth Road East has been observed, this may be a popular access point for visitors.



.8 Eighth Road East to Tenth Road East

Ninth Road East does not extend through this area, so the trail is uninterrupted between Eighth and Tenth Road East. The gate on the east side of Eighth Road East is in the standard arrangement. The trail surface between Eighth and Tenth Road East is stone chip, but the mown grass is encroaching on the trail surface for various lengths leaving a narrow stone chip path down the center. This trail section is very open, mostly passing between agricultural fields. Hedgerows along some parts of the trail section provide shade and windbreak.

There is an interpretive sign about 130 meters east of Eighth Road East that is in very poor condition. The sign panel has deteriorated leaving only about 50% of its content. There is a steel bridge crossing Forty Mile Creek near Tenth Road East that appears to be in good condition. Along Tenth Road East, there is an active quarry run by Waterford Sand and Gravel on the south side of the trail that produces a fair amount of noise. The quarry property is fenced off from the trail and has “No Trespassing” signs posted. The Canadian Pacific Railroad crosses the trail at Tenth Road East. The trail follows on Tenth Road East and does a jog across the railroad tracks, the safety of this crossing should be reviewed.



On the north side of the trail west of Tenth Road East is the Vinemount Meadows Sanctuary, a 65-acre (26.3 hectare) bird and pollinator habitat created in partnership between the Hamilton Naturalists Club and Waterford Sand and Gravel. There is an interpretive sign in good condition with information about the Sanctuary located beside the trail. There is another interpretive sign with information about the Dofasco Trail located on the east side of Tenth Road East, this sign is in very poor condition. There is a section of widened gravel shoulder along the east side of Tenth Road East. This area was originally envisioned as a staging area for the trail with 87 Acres Park to the south. However, 87 Acres Park is not open to the public. The gates on the west side of Tenth Road East are in the standard configuration.

Improvements to the trail signage and updated interpretive signage is recommended for the Tenth Road East location. Due to the closure of 87 Acres Park, this area no longer serves as a formal staging area for the trail and only a few cars may pull off at this location.

.9 Tenth Road East to Eleventh Road East

The intersection at Tenth Road East poses some challenges for trail navigation. The trail alignment is interrupted by the railway tracks, and there are no trail gates on the east side of Tenth Road East.

A private driveway on the east side of the road, and the trail entrance, merge at this location. Trail wayfinding and safety signage could be improved in this location.



On the east side of Tenth Road East the lands south of the trail contain several large satellites, noise producing generators, and industrial equipment visible from the trail. During the City planning approvals for this property HCA requested fencing be installed at the property boundary to buffer the trail. At the time of this review, no fencing exists.

Continuing east on the trail, there is a forested section and then the trail opens up through to Eleventh Road East. The trail surface through this section is stone chip. There is a steel bridge crossing Forty Mile Creek near Eleventh Road East that appears to be in good condition. From the east end of the satellite dish property through to Eleventh Road East, the trail is fenced on both sides. There are two set of gates along the trail providing access to the agricultural fields on either side. The gate at Eleventh Road East is in the standard configuration.



.10 Trail Access Agreements

Trail management of the off-road trail is carried out as per the current signed partnership agreement between the City of Stoney Creek (now City of Hamilton) and the HCA. This long-term agreement is anticipated to remain in effect beyond the life of this plan. HCA welcomes further discussion with the City on this agreement anytime that the ownership of this trail by the City is under review.

Our infrastructure review notes there are locations where adjacent landowners are observed using the trail to access their land. The current access agreements are subject to further review by HCA and the City on a case by case basis. Unauthorized motor vehicle activity anywhere along the trail is also subject to review and trespassing enforcement by HCA and the City.

At the Tenth Road East the Canadian Pacific Railway has right-of-way access across the trail.

Waterford Sand & Gravel Limited has access over the trail to their monitoring wells, and Ontario Hydro has access for their lands near First Road East.

Approximately 2.5km of the eastern end of the trail is located within the Niagara Peninsula Conservation Authority (NPCA) watershed. At the time of trail construction letters of support from NPCA were provided to HCA to develop the trail within their watershed.

5.2 Connections to Hamilton Conservation Areas

The Dofasco Trail connects to Devil's Punchbowl and Saltfleet Conservation Areas. These locations are the primary parking and trail-head staging areas. From the Bruce Trail at the Punchbowl, secondary access to HCA's east mountain conservation areas such as Vinemount, Winona, and Felker's Falls is possible. Along the Bruce Trail, the nearest Escarpment conservation areas in the NPCA watershed are Woolverton and Beamer Memorial.

Within the City of Hamilton, other trails within cycling distance of the Dofasco Trail include:

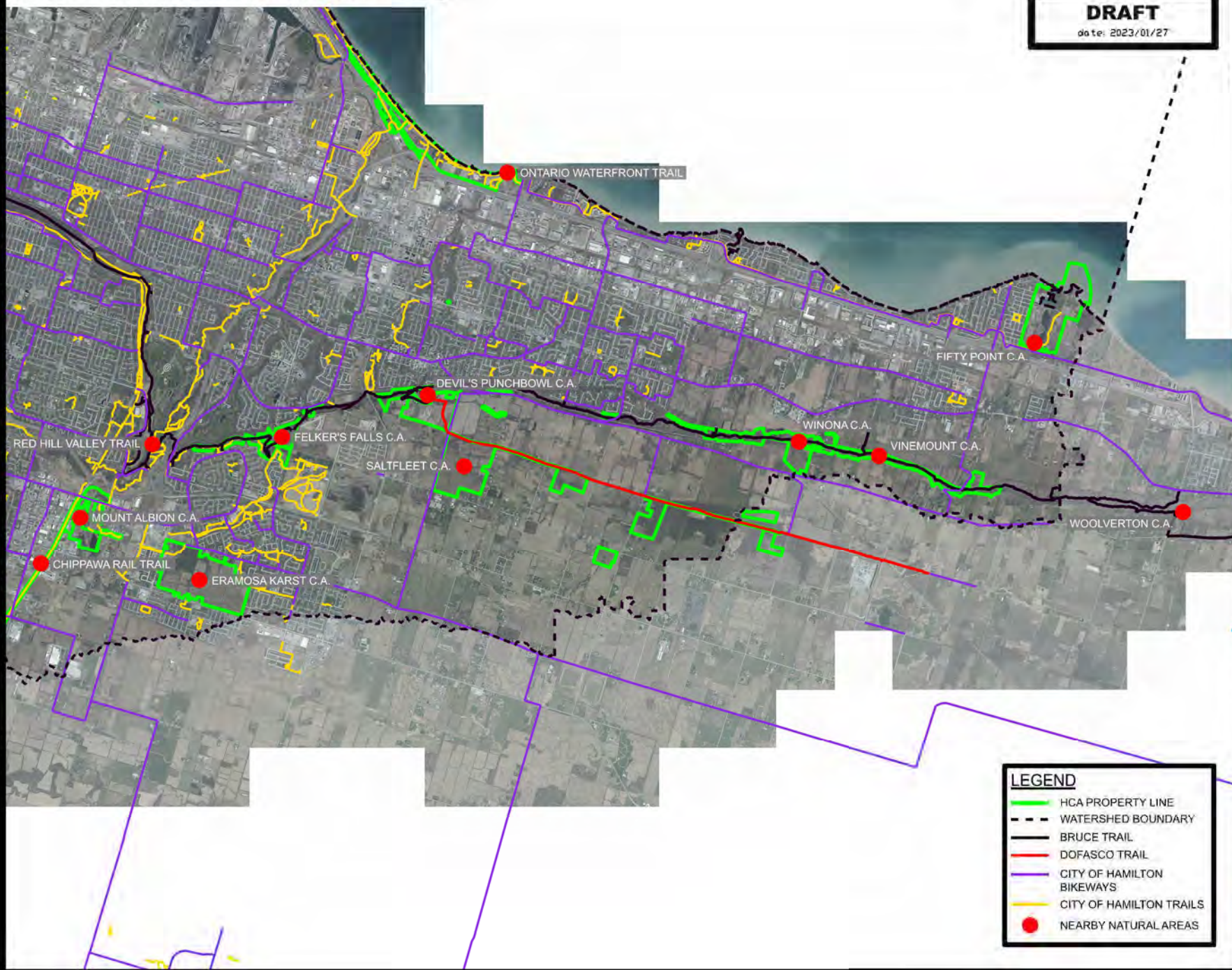
- Ontario Waterfront Trail along the shore of Lake Ontario
- Red Hill Valley Trail
- Chedoke Radial Trail
- Ontario Greenbelt Route
- Trans Canada Trail
- HCA's Chippewa Rail Trail
- The Niagara Escarpment Rail Trail

See Figure 4. for locations of nearby trails and natural areas.

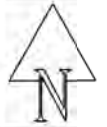
Public transportation offered by the City of Hamilton allows for hikers and cyclists to reach the Dofasco Trail, with some effort, from the nearest bus stops in Stoney Creek.



FIGURE 4. SURROUNDING TRAILS AND NATURAL AREAS



DRAFT
date: 2023/01/27



**SURROUNDING TRAILS AND NATURAL AREAS
DOFASCO 2000 TRAIL MANAGEMENT PLAN**

DATE: 2023/01/27

LEGEND

- HCA PROPERTY LINE
- - - WATERSHED BOUNDARY
- BRUCE TRAIL
- DOFASCO TRAIL
- CITY OF HAMILTON BIKEWAYS
- CITY OF HAMILTON TRAILS
- NEARBY NATURAL AREAS



6.0 MANAGEMENT PRACTICES

6.1 Natural Heritage Conservation

The Dofasco Trail is an important recreational trail within the system of open space and natural areas in the City. The off-road trail on un-opened road allowance crosses three Environmentally Significant Areas (ESA). No new trail development other than routine maintenance of the trail surface, bridges, culverts and boardwalks is proposed. No trail impacts to the adjacent ESA's are anticipated for the lifespan of this Management Plan. However, it should be noted that invasive species will need to be monitored and managed along the trails. See Section 4.0 for more information.

It should be noted that two endangered tree species occur along this trail, Butternut and Black Ash. Further assessments are required before these trees can be removed, even if they are hazards. In addition, Dog-Strangling Vine a very aggressive invasive plant species occurs along the trail within Tapleystown Woods. Trail mowing and maintenance should include clean equipment protocols to discourage the movement of this species further. Management of this species will be a high priority.

6.2 Water Management

Water crossings on the trail are not considered to be navigable under the Federal Navigation and Protection Act (formerly the Navigable Waters Protection Act), thus crossings do not have to provide for navigation.

The watercourses within the area of the trail are mostly intermittent in nature, although they still are direct fish habitat, as fish have been found in the area of all crossings in the HCA's watershed. The fish will move to deeper pools when the shallower sections dry up. This highlights the importance of ensuring all crossings are constructed to facilitate fish passage to avoid trapping fish and preventing them from being able to access the deeper pools of the system for refuge.

No new trail development is proposed that could adversely affect water resources. Should replacement of culverts, bridges and boardwalk features along the off-road trail be required, HCA will adhere to federal, provincial and local policies and regulations.



6.3 Conservation Area Experience

The former City of Stoney Creek and HCA worked together to create this trail and provide recreational opportunities for the public. Key values of this vision supported by this plan include conserving and managing public open space and natural habitat; offering the community and visitors recreational and educational benefits; and supporting community health and well-being connecting people to nature.

This Management plan supports this original vision for the trail, and in linking Devil's Punchbowl Conservation Area to Eleventh Road East in Stoney Creek. As well, this plan supports the broader vision of recreational trail connections to the rural areas of Stoney Creek with potential linkages throughout the City of Hamilton and beyond.

The trail use is primarily directed towards bicyclists and walkers, with the main access and parking at Devil's Punchbowl and Saltfleet Conservation Areas. Secondary access and limited roadside parking are available at Fifth Road to view the Vinemount South Swamp, and along the shoulder of Tenth Road East near the eastern end of the trail. While some roadside parking occurs near the trail gates between Second and Eleventh Road East, for public safety HCA is not recommending parking at these locations.



When offsite parking is found to be causing traffic and safety issues, HCA will enlist the assistance of municipal agencies for traffic control. Traffic control will be evaluated on a case by case basis by all agencies involved. Should this be a persistent problem HCA will work with municipal partners on traffic and visitor management strategies and solutions.

The original Master Plan for the trail noted creating an entrance node at 87 Acres Park, located at Tenth Road East and Green Mountain Road. At Tenth Road East there is a remnant interpretive sign from the original trail construction in poor condition along the shoulder. All of the signage at this location needs updating and to clearly identify the trail.

The 87 Acres Park was originally a Vinemount Quarries property and subsequent to the quarry's closure was transferred to the City of Stoney Creek for use as a non-hazardous landfill site. The landfill was officially closed in 2005 with the intent of creating the nature park for the public. The large quarry pond currently provides habitat for waterfowl and wildlife, and while the site offers potential for passive recreation and parking it is currently closed to the public and being monitored by the City.



The only public access from Tenth Road East into 87 Acres Park is for the Stoney Creek Hawks Remote Control Model Aircraft Club field. This club was established in 1977, however the field was being used as a radio control flying site in 1969 and is probably one of the older radio control flying sites in Canada. Club members keep the gated access to their field secured for their sole use.

Due to the uncertainty surrounding the opening of 87 Acres Park to the public, and the long-term operation of the aircraft club at this location, the 87 Acres Park property is not being considered as an entrance node nor trail-head for the Dofasco Trail. Should the land use of this area change in future, HCA welcomes the opportunity to discuss potential connections with the Dofasco Trail.

6.4 Education and Environmental Awareness

The existing interpretive signage on the trail provides some educational information on the natural features and history of the area. This signage is in poor condition and is recommended to be replaced with a new interpretive signage program designed for the trail. The addition of rest areas for the trail as recommended in Section 5.1 could also serve as interpretive educational stations. The trail-head staging areas at DPCA and Saltfleet CA are also prime locations where educational information can be offered. Further study of design options is recommended, as well as considering community donors and partnerships for interpretive features and programs, prior to replacing the current signage.



The existing wood trail signs will need updating and refreshing during the life of this plan to HCA's current sign standards. During the roll-out of new signage, communicating educational information to the public with these installations is recommended.

New digital technological opportunities are also recommended to promote and describe the trail and its features. Currently HCA offers an online trail brochure, and the HCA website provides information on trail etiquette guidelines, rules and regulations. The trail brochure is recommended to be updated once this Management Plan is posted on the HCA website. Educational information could also be provided by mobile digital applications for self-guided use on the trail (story-telling apps for example).

6.5 Management Guidelines

.1 Permitted Uses

Permitted passive recreation activities include walking, dog-walking, hiking, bicycling (with exceptions for e-bikes noted below), winter snowshoeing, and geocaching.

The Accessibility for Ontarians with Disabilities Act (AODA) proposes improving access to trails for persons with a disability. Persons requiring use of a motorized wheelchair are permitted access to the Dofasco trail. The ability of a wheelchair to navigate the trail will depend upon the trail surface, trail grade, and weather conditions. The maintenance guidelines laid out in this plan along with the recommended trail infrastructure improvements (Section 7.1) will help to increase the accessibility of the trail. These steps include resurfacing the trail and improving sloped areas where possible, maintaining and increasing the trail width to HCA standards, maintaining a vertical clearance of 2.1m, and adding more rest stops along the trail.

HCA is considering restricting equestrian use, pending further review of the trail conditions and infrastructure (bridges, boardwalks) required for safe trail use. Horse riding may be restricted from portions of the trail, or the entire trail pending this review and at HCA's management discretion considering trail user safety.

For power-assisted bicycles, HCA follows the provincial regulations for electric bikes (e-bikes) as per the Ontario Ministry of Transportation. E-bikes that meet provincial requirements are allowed on roads and highways where conventional bicycles are currently permitted. The regulations also permit exceptions where e-bikes may not be used including municipal roads and sidewalks where bicycles are banned under municipal bylaws, bike paths, bike trails, or bike lanes. Currently e-bikes (including power assisted scooters) are not permitted on the Dofasco trail and HCA recreational trails. It is recommended that HCA further review e-bike use and permissions with the City for the Dofasco Trail should e-bike use be found to be increasing in the community and observed on HCA trails.

.2 Restricted Uses

The use of motorized vehicles is not permitted on the trail, with the exception of maintenance and emergency vehicles, and motorized wheelchairs noted previously. Hunting and trapping are not permitted on or from the trail corridor. Dogs off leash are not permitted. No open fires or camping are permitted. Unauthorized property access and encroachment are not permitted and will be addressed by the City of Hamilton and HCA on a case by case basis.

.3 Agreements

The management of the off-road trail will be carried out as per the current partnership agreement between the City and the HCA. Some portions of the trail are accessed by adjacent landowners under past agreements. The City of Hamilton may require updated access agreements for continued use, on a case by case basis.

HCA values the community support from area residents and landowners, businesses, service clubs, and volunteer organizations that currently or could contribute to the trail in a variety of ways. The HCA will continue to nurture existing support and will seek out new opportunities for trail partnerships.

6.6 Maintenance Guidelines

.1 Vegetation Clearing

The existing trail is intended to be 1.5m to 1.8m wide with a clearing width of 2.4m. Vegetation is to be removed within this clearing width as necessary to ensure safe sight lines, reduce hazards, and prevent encroachment of vegetation onto the trail. Any vegetation clearing beyond this shall only be done on a site-specific basis subject to review by HCA and the City. Best management practices are to be followed so that maintenance activities, equipment, and tools do not spread invasive species.

.2 Fencing

No new fencing is proposed for the off-road trail. Fencing is only to be considered on a site-specific basis by the City and HCA in accordance with requirements of the provincial Line Fences Act and local By-laws.

.3 Lighting

The trail will not be lit and is intended to only be open sunrise to sunset.

.4 Garbage Collection

Garbage cans may be made available by HCA at the conservation area trail head parking lots if demand warrants. Generally, garbage cans are not provided along the trail route. Trail users will be encouraged to practice 'pack in-pack out' trail etiquette.

.5 Washrooms

Currently no washrooms are provided along the trail. Information signs may be used to direct trail users to conservation area parking areas and washrooms. HCA has acquired lands at the Punchbowl Market buildings and is investigating expansion of parking and visitor services at this location, including washrooms. HCA is also considering providing washroom facilities at Saltfleet Conservation Area. More information is available in the 2022 Saltfleet and Devil's Punchbowl Master Plans.

.6 Winter Maintenance

There will be no snow removal along the trail.

.7 Signage

Five types of signs are permitted along the trail: information, designation/direction, regulatory, warning, and interpretive. Information signs are intended to provide general information about the use, identify the trail and may include a map. Designation/direction and regulatory signs are to be placed along the trail at each road crossing. Warning signs will be placed where there are anticipated safety concerns, such as areas with quarrying and agricultural activities.



Interpretive signs may be provided along the trail as part of a planned educational program. All signs are to follow standard formats of the HCA and City. Most signs will include a logo, trail name in addition to the information being conveyed.

.8 Road Crossings

The trail crosses nine roads. All road intersections and at the trail shall be signed for vehicle traffic and trail users. Gate structures shall be maintained at each road crossing to prevent unauthorized motor vehicle access to the trail, and provide a visual warning for the trail user prior to crossing the road. Vegetation shall be pruned only as necessary to provide sight lines for trail user safety.

Traffic volumes and the risk to pedestrian safety shall be monitored by HCA and the City. Future traffic volumes may warrant additional design features for public safety. Public safety features such as road crosswalks (signage, line painting, crosswalk lights) are subject to review and approval by the City.

.9 Watercourses

Trail maintenance at watercourse crossings is to be reviewed by HCA and the City when features such as culverts, boardwalks, bridges and associated structures require maintenance or replacement.

.10 Invasive Species

As noted in Section 4.1 the following invasive species have been found along the Dofasco Trail: Common and Glossy Buckthorn, Autumn Olive, Multiflora rose, Garlic Mustard, Dog-strangling and Phragmites. This section details these invasive species.

.1 Common Buckthorn

Common buckthorn is a small tree or shrub that was introduced to Ontario from Eurasia. It was widely planted in farm hedgerows and fencerows as a wind break. It can survive in a wide range of conditions making it very good at invading a variety of habitats (Anderson, 2012a). Birds and

small mammals feed on the berries of this plant, which has caused it to spread along the trail. Large numbers of this species grow along the trail within the Vinemount swamp section as well as interspersed along other portions of the trail. This species is often growing with poison ivy making removal very difficult. Monitoring of the spread of this species will occur and treatment where possible may begin with fruiting females to slow the overall spread. This is a high moderate.

.2 Glossy Buckthorn

Glossy buckthorn (*Rhamnus frangula*) is a member of the buckthorn family that mainly grows in wet areas, but can be found growing alongside Common Buckthorn in other habitats (Anderson, 2012a). This is a non-native tree species introduced from Eurasia about 100 years ago (NCC, n.d.). This species forms dense thickets that shade out native species. They produce a dark berry that ripens in late summer and is eaten by birds. The birds disperse the seeds. It is very invasive due to its high seed production and tolerance for varied growing conditions. Glossy Buckthorn is growing among common buckthorn along the trail. It tends to be a weak plant and is easily pulled when small. Herbicide treatment can follow the same methodology as Common Buckthorn since they are closely related and will likely be treated concurrently. Monitoring will occur with this species as well due to its growth pattern with Poison Ivy.

.3 Phragmites

This species of common reed from Eurasia is a perennial grass. It is not clear how it was transported to North America. It is an aggressive plant that spreads quickly and out competes other native species in wetland habitats (Nichols, 2020). It forms large mono cultures that decrease plant biodiversity and creates poor habitat for wildlife. There are small patches growing along the boardwalk in the Vinemount Swamp as well as a small patch near Tenth Road East. An effective control strategy would likely include pesticide application during the dry period for this community (September/October) (Nichols, 2020). Assessments can be made in coming years to see if the swamp is dry enough in the fall for a spray. It is a top priority species to be controlled at HCA.

.4 Garlic Mustard

This species was introduced in the 1800's from Europe as an edible herb for early pioneers in the spring. It is a biennial plant that produces seed in its second year (Anderson, 2012b). It can grow in a variety of conditions making it a very good invader in a variety of habitats. It easily outcompetes other native ground cover and can change the soil environments to favour its growth over others. Garlic Mustard can be found growing in patches within the Tapleystown woods and small shaded areas along the trail. Removal of this species is fairly straight forward with hand picking between April and June, before the plant goes to seed. With a dedicated effort over 5 years removal of this species can be achieved. This is a high priority because it is easy to remove and there is limited extent of this species along the trail.

.5 Multiflora Rose

Multiflora rose is a large perennial shrub that was introduced to North America in the late 1700s for horticultural purposes, and was widely promoted in the 20th century for a variety of uses (Warne, 2018). This plant grows quickly, can self-pollinate, produce up to 500,000 seeds a year or more, and forms dense thorny thickets rapidly crowding out native biodiversity. Seeds are widely spread through animal's consumption of the plant's fruits, and can be viable in the seed bank for up to 20 years (Warne, 2018).

There are a few seedlings located along the trail. Hand pulling is an effective control method for seedlings, however larger shrubs will aggressively re-sprout if cut without removing the roots. Therefore, a weed wrench and/or shovels should be used to fully remove the plant. This is a labour-intensive solution, and should prioritize small populations and sensitive areas. Alternatively, glyphosate-based chemical herbicide can be applied in late summer or early fall. A follow up-treatment may be required the following year, with ongoing monitoring to eliminate new seedlings (Warne, 2018). This is a high priority due to low numbers and the ease of removing this species.

.6 Dog Strangling Vine

Dog strangling vine (*Vincetoxicum rossicum*) is an extremely invasive perennial which forms thick mats of vines crowding out all other vegetation (Anderson, 2012b). It is unclear how the European native arrived in Canada, but the first record is from Toronto in 1899. Dog strangling vine is a successful invader through altering the chemical composition of the soil, growing so densely it dominates ground cover, and producing many seeds which are readily carried by the wind.

Small pockets of Dog Strangling Vine occur along the trail within Tapleystown Woods. Individual plants can be dug up so that all parts of the root are removed from the soil. Alternatively, herbicides can be applied to plants before their seed pods fully develop (May to August). Tarping to desiccate plants is not a viable solution for this population due to the lack of sunlight reaching the forest floor in this area. It is likely multiple years of treatment will be required until the seedbank is depleted. If staff cannot meet this timeline, the seed pods should be removed from all plants before maturity in order to control the spread (Anderson, 2012b).

.7 Autumn Olive

Autumn Olive is a shrub native to Asia and was introduced in the United States in the early 1800s. It is a prolific seed producer and grows rapidly in ideal conditions. It forms dense thickets that shade and outcompete native species (OIPC, 2023). This species occurs along the trail in low population density. As there are few shrubs, this would be a high priority for removal. Small populations can be pulled or mechanically mulched. Larger infestation should be controlled chemically.

Within the 2.4m clearing width of the trail, invasive species are to be managed by HCA. Best management activities are to be followed so that maintenance activities, tools, and equipment do not spread invasive species.

A separate and more detailed invasive species management plan is recommended in order to plan and prioritize work on the Dofasco Trail with other invasive species projects in the watershed.

7.0 SUMMARY

7.1 Implementation Priorities

Over the last 20 years, the Dofasco 2000 Trail has provided a valued link between the Devil's Punchbowl Conservation Area and Eleventh Road East in Stoney Creek, City of Hamilton.

This Management plan provides current information on the off-road trail portion managed by HCA, and provides guidance for trail management and operation for the next ten years.

Continued safe enjoyment of the trail will require some capital work to be completed to replace aging trail infrastructure. The following items are recommended to be implemented in order of priority to achieve this goal:

.1 Environment Management:

From our ecological reviews of natural areas adjacent to the trail, key recommendations for the next ten years include:

- Terrestrial review of vegetation and invasive species within the trail clearing width.
- Invasive species control, focused on Dog-strangling vine, Phragmites and Autumn Olive
- Replanting along the trail as invasive species are controlled to restore natural regenerating ecosystems.
- Aquatic review of watercourse crossings to ensure safe fish passage and as infrastructure requires maintenance or replacements.

.2 Trail Infrastructure Improvements:

The following improvements are recommended for the recreational trail. These improvements support a safe visitor experience, and protect adjacent lands and natural areas:

- Provide trail-head amenities at Devil's Punchbowl and Saltfleet Conservation Areas.
- Implement a trail signage replacement program.
- Provide trail fencing and buffers as necessary to protect adjacent lands and natural areas.
- Improve trail surfacing for the entire length of the trail.
- Improve buffering along trail between Tenth and Eleventh Road East.



.3 Conservation Area Connection Improvements:

The following improvements are recommended to improve trail connections and linkages to HCA Conservation Areas:

- Improved pedestrian trail crossing of First Road East in co-ordination with City of Hamilton.
- Install trail wayfinding signs to connect with Devil’s Punchbowl Conservation Area.
- Install trail wayfinding signs to connect with Saltfleet Conservation Area.
- Install trail identification and wayfinding signs on Powerline Road in co-ordination with City of Hamilton.



8.0 APPENDIX CONTENTS

APPENDIX 1	Mapping
APPENDIX 2	Capital Development Priorities
APPENDIX 3	Trail Counter Data
APPENDIX 4	References

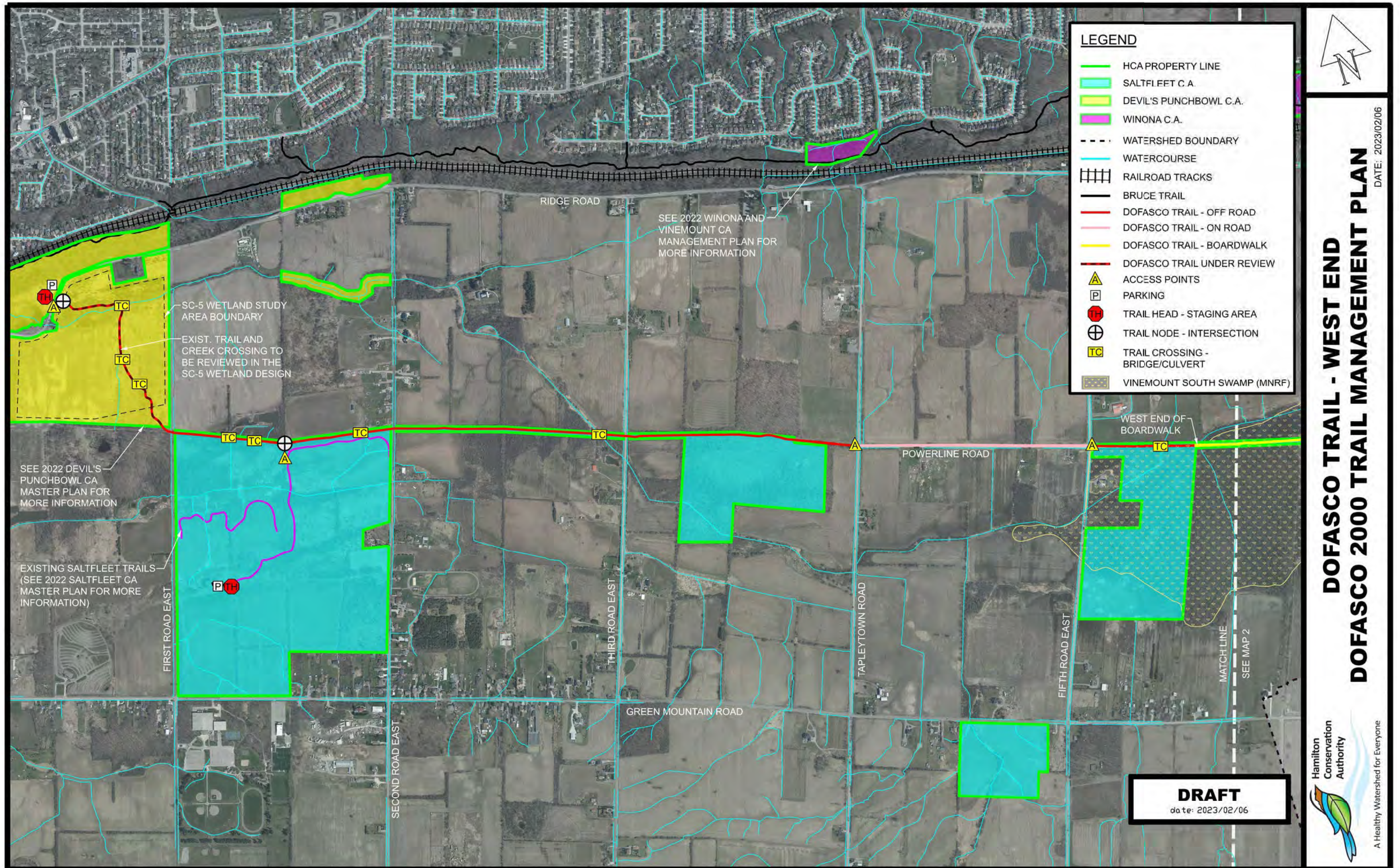
APPENDIX 1

Mapping

Map 1 Dofasco Trail – West End Portion

Map 2 Dofasco Trail – East End Portion

This page intentionally left blank.



LEGEND

- HCA PROPERTY LINE
- SALTFLLEET C.A.
- DEVIL'S PUNCHBOWL C.A.
- WINONA C.A.
- - - WATERSHED BOUNDARY
- WATERCOURSE
- RAILROAD TRACKS
- BRUCE TRAIL
- DOFASCO TRAIL - OFF ROAD
- DOFASCO TRAIL - ON ROAD
- DOFASCO TRAIL - BOARDWALK
- DOFASCO TRAIL UNDER REVIEW
- ACCESS POINTS
- PARKING
- TRAIL HEAD - STAGING AREA
- TRAIL NODE - INTERSECTION
- TRAIL CROSSING - BRIDGE/CULVERT
- VINEMOUNT SOUTH SWAMP (MNRF)

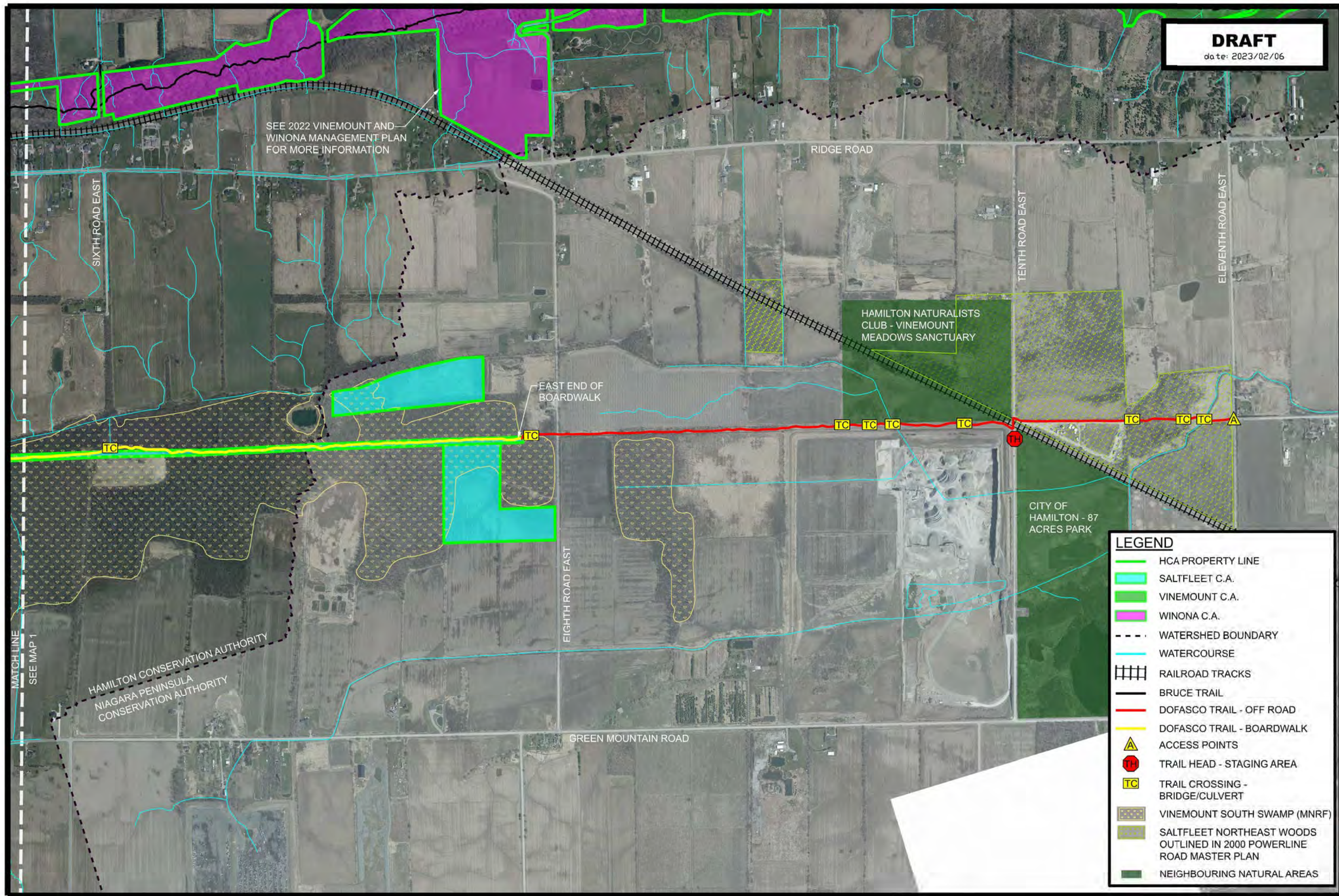
**DOFASCO TRAIL - WEST END
DOFASCO 2000 TRAIL MANAGEMENT PLAN**

DATE: 2023/02/06



DRAFT
date: 2023/02/06

DRAFT
date: 2023/02/06



SEE 2022 VINEMOUNT AND WINONA MANAGEMENT PLAN FOR MORE INFORMATION

EAST END OF BOARDWALK

HAMILTON NATURALISTS CLUB - VINEMOUNT MEADOWS SANCTUARY

CITY OF HAMILTON - 87 ACRES PARK

LEGEND	
	HCA PROPERTY LINE
	SALTFLEET C.A.
	VINEMOUNT C.A.
	WINONA C.A.
	WATERSHED BOUNDARY
	WATERCOURSE
	RAILROAD TRACKS
	BRUCE TRAIL
	DOFASCO TRAIL - OFF ROAD
	DOFASCO TRAIL - BOARDWALK
	ACCESS POINTS
	TRAIL HEAD - STAGING AREA
	TRAIL CROSSING - BRIDGE/CULVERT
	VINEMOUNT SOUTH SWAMP (MNRF)
	SALTFLEET NORTHEAST WOODS OUTLINED IN 2000 POWERLINE ROAD MASTER PLAN
	NEIGHBOURING NATURAL AREAS

DOFASCO TRAIL - EAST END
DOFASCO 2000 TRAIL MANAGEMENT PLAN

DATE: 2023/02/06



A Healthy Watershed for Everyone

APPENDIX 2

Capital Development Priorities

DRAFT - DOFASCO 2000 TRAIL CAPITAL DEVELOPMENT PRIORITIES: 2022 - 2032

A.	Trail Infrastructure Improvements	Budget* (485.5K)
A1	Wayfinding Signage – Trailheads	\$5,000
A2	Wayfinding Signage – Road Crossings	\$45,000
A3	Site Signage	\$2,500
A4	New Interpretive Signage	\$7,500
A5**	On-Road Trail Route Signs (Powerline Road)	\$3,000
A6	Trail Fencing and Barriers	\$5,000
A7	Stonedust Trail Improvements	\$300,000
A8	Culvert Replacement and Maintenance	\$30,000
A9	Trail Rest Areas and Site Furnishings	\$15,000
A10#	Trail Crossing on First Road East	\$2,500
A11	Invasive Species Management	\$50,000

* Budget costs are in 2022 dollars, projects and budgets to be reviewed annually.

** Dependent on City of Hamilton involvement.

Subject to change pending City of Hamilton involvement.

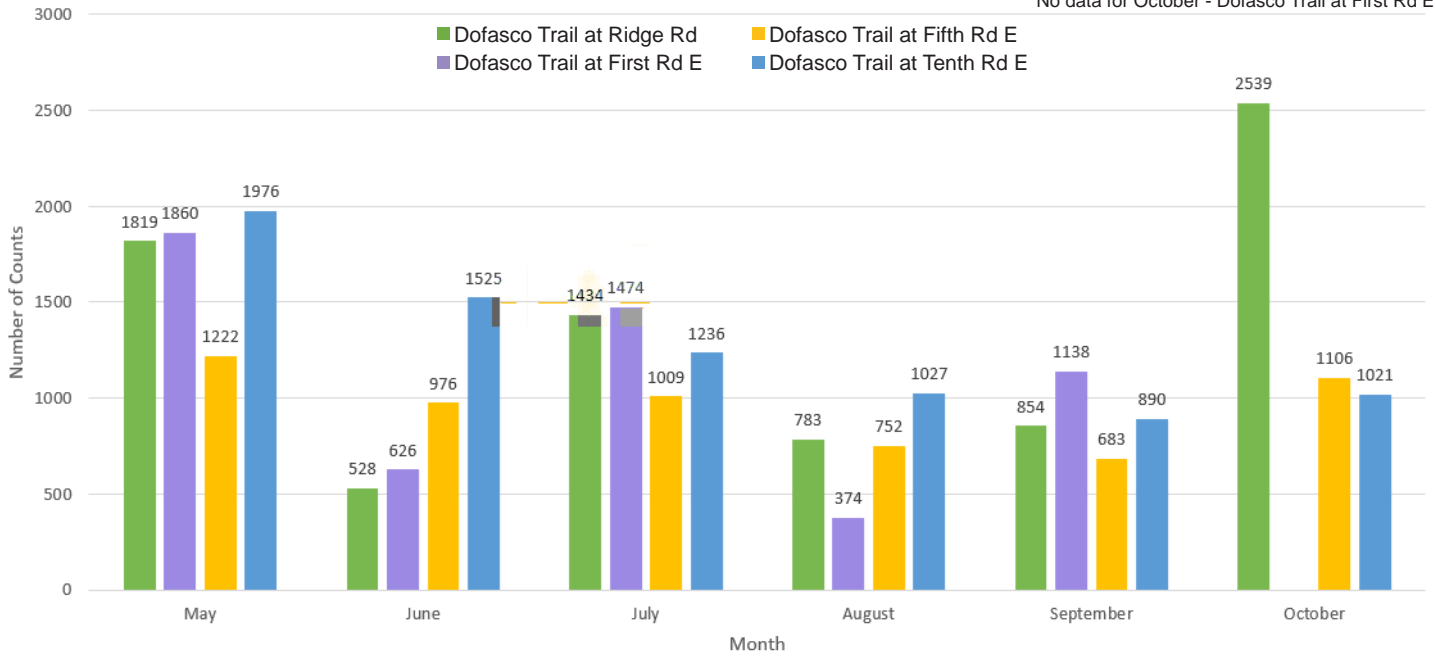
APPENDIX 3

Trail Counter Data

Trail Counter Summary

Dofasco Trail Counters - Monthly Totals 2022

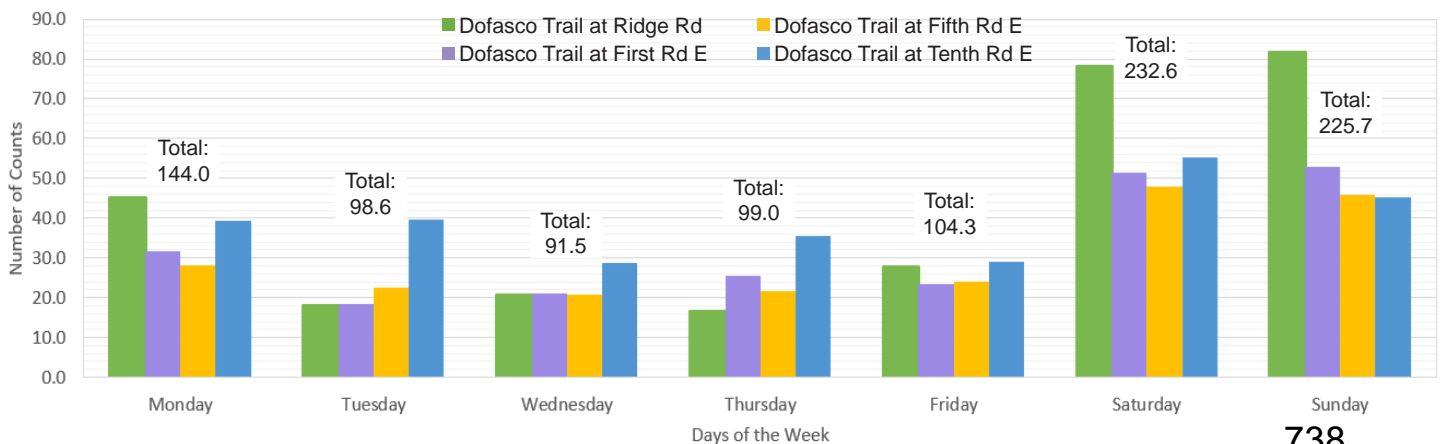
*No data for October - Dofasco Trail at First Rd E



Dofasco Trail Counters - Distribution Over the Whole Season



Dofasco Trail Counters - 7 Day Average



APPENDIX 4

References

References

Battlefield Creek Wetland Storage Facility Design Report (BC-1). Water's Edge Environmental Solutions Team & Hamilton Conservation Authority. August 20, 2021.

"*Dofasco 2000 Trail Official Opening*" opening ceremony document in HCA files. Hamilton Conservation Authority. October 14, 2001.

Powerline Road Trail Master Development Plan. July 6 2000. Appendix 2: 1999 Powerline Road Trail Agreement, Schedule A and B, between the Corporation of the City of Stoney Creek and the Hamilton Region Conservation Authority.



**Hamilton
Conservation
Authority**

A Healthy Watershed for Everyone



Hamilton Conservation Authority
838 Mineral Springs Road, P.O. Box 81067
Ancaster, Ontario, L9G 4X1
905-525-2181 www.conservationhamilton.ca

This page intentionally left blank.